



TURBOCHARGERS

Holset H2B/C/D/E/S

Service Repair Manual

WARNING

-  Turbochargers can be hazardous when not used as specified by the manufacturer. To prevent damage and personal injury:
- Always use the turbocharger part number specified by the engine manufacturer.
 - Use only in applications approved by the engine manufacturer.
 - Do not touch before checking surface temperatures.
 - Do not work on a running turbocharger or engine.
 - Do not modify the turbocharger in any way.
 - Disassemble and re-assemble using the engine manufacturer's instructions.
 - Use only approved spare parts.
- For advice on the safe use of turbochargers contact www.holset.com**

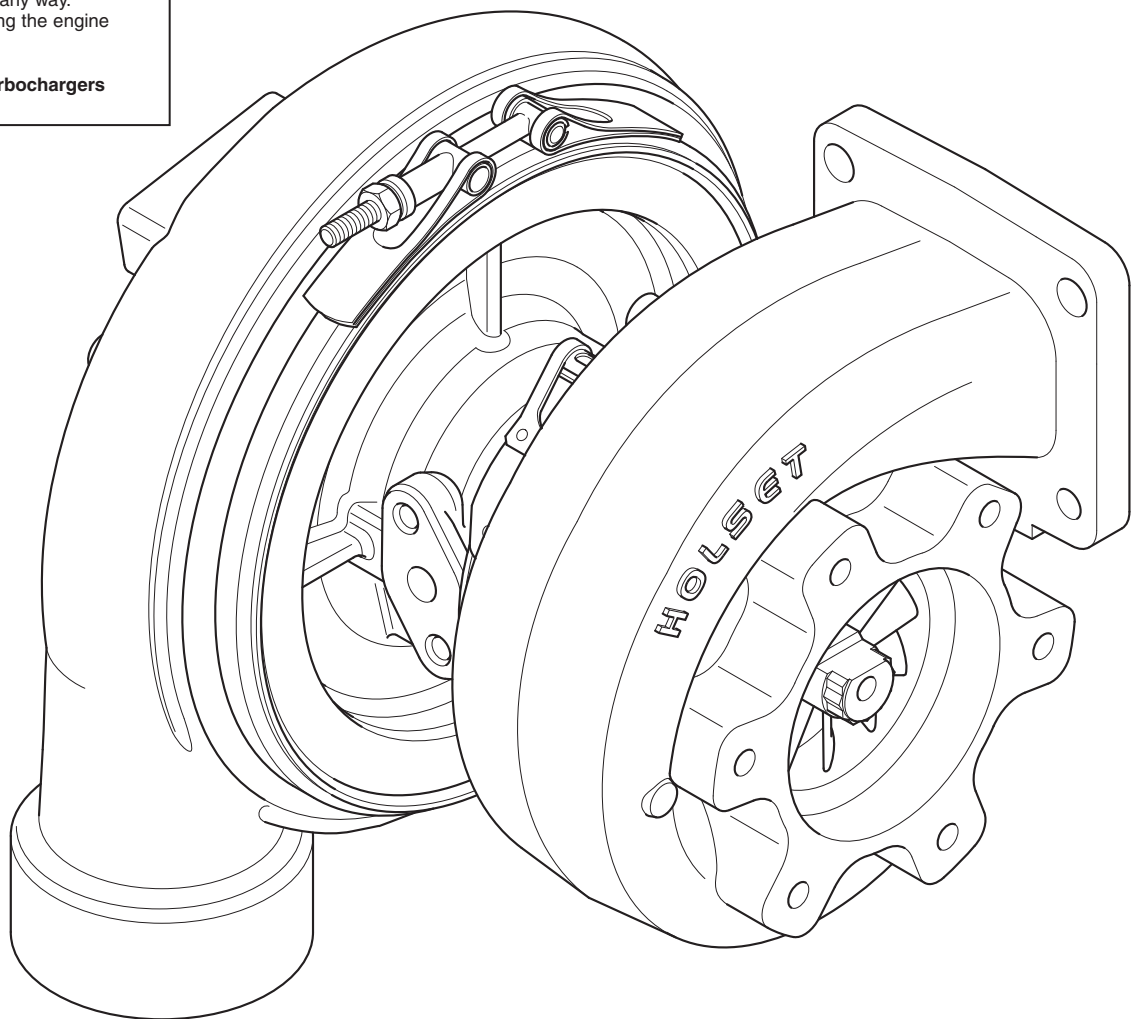

Foreword

This publication was written to assist with installation, maintenance and overhaul. It is not a warranty of any kind expressed or implied.

The specifications and procedures in this manual are based on information in effect at the time of publication. Holset Service reserves the right to make any changes at any time without obligation. If differences are found between your turbocharger and the information in this manual, contact your local Holset approved agent.

The latest technology and the highest quality standards are used in the manufacture of Holset Turbochargers. When replacement parts are needed, we recommend using only genuine Holset parts.

Table of Contents

1: Introduction

About the Manual	1:1
How to Use the Manual	1:1
How to Order Holset Original Parts	1:1
Description and Operation of Turbocharger	1:2
<i>General Information</i>	<i>1:2</i>
<i>Introduction to Turbocharger Matching</i>	<i>1:2</i>
<i>Notes, Cautions and Warnings</i>	<i>1:3</i>
Installation Data	1:4
Installation Checklist	1:5
Symbols	1:6

2: Component Identification

Turbocharger Identification	2:1
<i>Dataplate and CHRA (Core) of Turbocharger</i>	<i>2:1</i>
Exploded Views	2:2
Component List	2:5
Purchasable Service Tools	2:6

3: Troubleshooting and Diagnosis

Fault Finding Chart	3:1
--------------------------------------	------------

4: Component Testing and Replacement

Service Tools	4:1
On Engine Checks	4:2
Bearing Clearance	4:5
Turbine and Compressor Housings	4:6
Cleaning of Housings	4:13

5: Turbocharger Service and Overhaul

Service Tools	5:1
Disassembly	5:2
Component Cleaning	5:7
Inspection and Testing	5:9
Reassembly	5:13

6: Service Data Sheets

H Range Service Data Sheets	6:1
--	------------

About the Manual

The procedures in this manual were developed to instruct in the correct overhaul of the Holset HX50/52/55 turbocharger for optimum performance and minimum maintenance operation.

How to Use the Manual

The manual is split into sections designed to provide service information in a logical sequence. The manual contains links to help the user navigate between relevant sections. Users who are unfamiliar with navigating in PDF documents are referred to Navigating in PDF documents in the **Adobe® Acrobat® Reader™** help file.



Contents is an interactive page with links to all the sections. It can be accessed from any page in the manual by clicking this icon.

Section 1 defines the layout of the manual, introduces the reader to the operation of the turbocharger and presents important installation guidelines.

Sections 2, 3 and 4 concentrate on Turbocharger Component Identification, Troubleshooting and Diagnosis, Component Testing and Replacement.

Section 5 identifies the Service and Overhaul procedures to be followed in the unlikely event of a major turbocharger malfunction.

Section 6 quantifies build data to ensure the turbocharger will continue to operate to Holset Service standard on completion of overhaul.

Manual sections 1 to 5 where applicable, appear as a **self extracting** compressed file which is organised according to the steps needed to most easily and correctly maintain the operation of the turbocharger. Users are required to download this file to hard disk. Section 6 has its own file identity and resides at www.holset.co.uk. so that Holset can update the Service Data as changes occur. The links between manual and service data are active only when the user is connected to the Internet.

Chapter 6 has an expiry date to encourage users to discard outdated saved or printed versions and always access the latest information available at www.holset.co.uk.



When using the manual on-line this icon will link to Holset's website to help find your nearest agent for advice and how to order Holset original parts.

How to Order Holset Original Parts

To make sure of optimum performance, certain items must be discarded during disassembly and replaced with new for re-assembly. These items are indicated in the Service and Overhaul section with the use of a * symbol.

All items showing a * are available in a basic overhaul kit.

To get the correct parts for your turbocharger, refer to the 'component identification' section of this manual to help you find the following information:

- 1) Refer to the exploded view and component list to define the major components to be replaced.
- 2) Refer to the turbocharger's dataplate which will be found on the compressor cover or wastegate actuator to define the identifying information about your turbocharger build standard.
- 3) Contact your local Holset agent with component identification nos. and dataplate assembly no., serial no. and turbocharger type.
- 4) With this information, your local agent can provide you with the optimum kit of parts for re-assembling your turbocharger for continued long life operation.

Description and Operation of Turbocharger

General Information

A turbocharger is a mechanical device which uses the engine's exhaust gases to force more air into the engine cylinders. Hot exhaust gas energy is used to turn a turbine wheel and shaft. At the other end of the shaft is the compressor impeller (or compressor wheel), which draws in air and forces it into the engine cylinders.

Supplying increased air mass flow to the engine provides improved engine performance, lower exhaust smoke density, improved operating economy and altitude compensation. The turbocharger has proven to be one of the most beneficial devices for improving engine performance. It performs its job very well, as long as it is properly cared for.

Introduction to Turbocharger Matching

The need for optimised matching over the engine speed range

A standard turbocharger can be perfectly matched to only one particular engine condition, eg maximum torque speed or maximum load speed. At this engine speed, the turbocharger supplies the optimum mass of air to give the required air/fuel ratio. At other speeds the air/fuel ratio cannot be held at the optimum hence fuel consumption and emission levels worsen.

Engine emission legislations have forced manufacturers to improve their engine efficiencies, particularly at low speeds where low air/fuel ratios cause high smoke levels.

The Holset turbocharger is carefully matched to meet the required engine characteristics during application engineering. It is important that this match is maintained by using only Holset original turbine and compressor parts.

The importance of correctly servicing the turbocharger

A turbocharger requires accurate assembly at point of manufacture. It is very important to adhere to setting limits when servicing the turbocharger, as failure to do so could result in turbocharger or engine failure.

Effects of wrong match

Possible consequences if turbocharger boost pressure is too low:-

- Engine runs fuel rich
- Exhaust temperature increase
- Hydrocarbon levels increase
- High cylinder temperature risks damage to engine pistons
- Fuel consumption increase
- Smoke levels increase
- Risks of failing emissions tests

Possible consequences if turbocharger boost pressure is too high:-

- Engine runs fuel weak (lean)
- Excessive boost overspeeds turbocharger
- Increased cylinder pressure risks damage to engine head gasket, pistons and valves
- Nitrous oxide levels increase
- Turbocharger bearing failure and wheel fatigue problems
- Intercooler load increases causing engine to overheat, risking piston damage

Notes, Cautions and Warnings

Notes, Cautions and Warnings are used in this manual to emphasise important or critical instructions.

Note

Information which is essential to highlight.

Caution

Maintenance or Service procedures which if not strictly followed, will result in damage or destruction of the turbocharger.

Warning

Maintenance or Service procedures which if not correctly followed will result in personal injury or loss of life.

Note

Holset turbochargers can be remanufactured using recovered parts. Where it is necessary to dispose of components or whole turbochargers, an environmentally responsible process such as recycling should be used, with due regard to local laws.

Note

Holset Service receives many turbocharger returns that are no fault found. Before assuming the turbocharger is not performing to specification always refer to the engine diagnostic system and the troubleshooting diagnostic procedures of this manual.

Warning

Turbocharger surface temperature during operation can achieve 700°C (1300°F). The designated turbocharger weighs up to 21.1 kg (46.5 lb) and is fitted with external parts that are sensitive to manual handling.

Caution

This turbocharger has been manufactured using piece part and rotor balance processes and **MUST** be check balanced on rebuild.

If you intend to overhaul/repair a rotor balanced turbocharger, ensure that all the rotor parts have co-relation marks prior to disassembly so that they can be reassembled in the same relative positions.

Balance limits for turbocharger rebuild are shown on Holset's Service Data Sheet.

It is important to note that operating a turbocharger with a rotor or core balance level greater than the published limits could cause turbocharger or engine failure. If you are in any doubt regarding the balancing process, please contact an approved Holset agent for assistance.

Warning

Some parts are manufactured in Viton that requires special treatment in the case of repair and service after fire.

Installation Data

1. Holset Service receives many turbocharger returns that are no fault found. Before assuming the turbocharger is not performing to specification always refer to the engine diagnostic system and the fault finding chart of this manual to make all the recommended health checks.
2. It is important that intake and exhaust systems are fitted in accordance with the recommendations of the Equipment and Engine manufacturers. Limiting mass inertia loading is critical to turbocharger wholelife operation. Maximum engine vibration input must not exceed 10g.
3. The air filter must remove particles greater than 5µm at an efficiency of 95% and be of sufficient capacity to match the air consumption of the engine. Recommended filters should always be used with a pressure drop indicator. Intake systems must be capable of withstanding depressions up to 6.9 kPa (1.0 lbf/in²).
4. Hose and clip connections of intake manifold systems must be capable of withstanding the turbocharger pressure ratio. V band clamps are preferred and must be used above 3:1 pressure ratio.
5. Exhaust systems must be capable of operating at exhaust back pressures of up to 10 kPa (1.5 lbf/in²). This limit is increased to 13.4 kPa (2.0 lbf/in²) if a catalytic converter is fitted. Exhaust brake applications are permitted to impose 450 kPa (65.3 lbf/in²) back pressure.
6. Oil should be filtered to 10µm with efficiency of 60% TWA (Time Weighted Average) /20 µm with efficiency of 85% TWA. Efficiency assessed using ISO Standard 4572/SAE J 1858.
7. The oil quality must be as specified by the engine manufacturer and will be a minimum API SE - CD (MIL - L - 2104C) specification. Improved life can be obtained by using super high performance diesel (SHPD) oils, particularly in industrial applications which use extended oil drain periods.
8. Normal oil temperature is 95+/-5°C (203+/-9° F). It should not exceed 120°C (248°F) under any operating condition.
9. Any pre-lube oil must be clean and meet the minimum CD classification.
10. The orientation of turbine housing, bearing housing and compressor cover is fixed according to application. During installation, do not attempt to rotate these components. Inclined turbocharger installation is not recommended. If an installed angle is necessary, oil inlet centreline must be +/- 10 degrees from vertical and rotor centreline +/- 5 degrees from horizontal.
11. Holset permits oil return pipes to decline at an overall angle of not less than 30 degrees below horizontal. All turbocharger applications require a pipe of internal diameter greater than 19 mm which has integrated connectors. To ensure oil returns into the engine under all operating conditions, the return connection into the engine sump must not be submerged and the outlet flange of the turbocharger must be 50 mm above the maximum oil level of the engine sump pan. Crankcase pressure should be limited ideally to 0.8 kPa (0.12 lbf/in²) but 1.4 kPa (0.20 lbf/in²) can be accepted by reference to Holset.
12. Oil pressure of 150 kPa (20 lbf/in²) must show at the oil inlet within 3 - 4 seconds of engine firing to prevent damage to turbocharger bearing system. A flexible supply pipe is recommended.
13. The minimum oil pressure when the engine is on load must be 210 kPa (30 lbf/in²). Maximum permissible operating pressure is 400 kPa (58 lbf/in²) although 600 kPa (88 lbf/in²) is permitted during cold start up. Under idling conditions pressure should not fall below 70 kPa (10 lbf/in²).
14. Recommended oil flows for the turbochargers are 3 litre/min at idle and 3.5 - 4.5 litre/min above maximum torque speed.
15. Do not use liquid gasket substances or thread sealant as any excess can enter the turbocharger oil system to obstruct flow.
16. Recommended coolant flows for the turbochargers are 3 litre/min at idle and 10 - 14 litre/min above maximum torque speed.

Note:

100 kPa = 1 bar (14.5037 lbf/in²=psi).

Installation Checklist

1. Always understand why the original turbocharger needs replacing before fitting another unit.
2. Check the turbocharger dataplate to ensure the Part No. is correct for the engine/application.
3. Check the engine exhaust, intake and aftercooler systems are clean and without obstruction i.e. free from oil, gasket pieces, dust/dirt/carbon or foreign objects.
4. Replace the oil and air filters using replacement parts specified by the equipment manufacturer.
5. Change the engine oil using the type specified by the engine manufacturer.
6. Check that the turbocharger oil inlet and drain pipes and connectors are clean, free from obstruction and will not leak under pressure. Before re-installing flexible pipes always ensure any burnt-on lacquer or other adhered material is removed from internal bores. If in doubt, always use new pipes.
7. Check that the coolant pipes of water cooled bearing housing applications and connectors are clean, free from obstruction and will not leak under pressure.
8. To pre-lube the turbocharger bearings, pour some clean engine oil into the oil inlet and rotate the turbocharger rotor assembly by hand.
9. Check that the exhaust manifold flange is flat and undamaged. Mount the turbocharger on the flange and check that the turbine inlet gasket fits properly without obstructing the gas passages.
10. Assemble the air intake and boost outlet connections. Check that the connections are secure and will not leak in use.
11. Check the exhaust system is fitted using the original mounting arrangement provided by the equipment manufacturer. Always re-fit any supports/brackets back in position to ensure the system is correctly supported.
12. Assemble the exhaust system to the turbine housing outlet. Check that the gasket/connection is secure and will not leak in use.
13. Assemble any coolant pipes and check that the connections are secure, without obstruction and will not leak in use.
14. Assemble the turbocharger oil inlet pipe and check that the connection is clean, secure and will not leak in use.
15. Check all clamps and fasteners are correctly tightened to the torque recommended by the equipment manufacturer.
16. Make any ECU checks recommended by the engine manufacturer.
17. Crank the engine WITHOUT firing until engine oil flows out of the turbocharger drain flange.
18. Assemble the oil drain pipe and check that the connection is secure, without obstruction and will not leak in use.
19. Start the engine and run at idle speed for approximately 1 minute so that the oil supply system is fully operational.
20. Accelerate the engine and check that there are no leaks/obstructions of air/oil/coolant/gas under pressure.
21. Check that no hose or connection deforms under normal operation.
22. Before switching off the engine, leave it running at idle speed for at least 1 minute to cool the turbine.

Symbols

Symbole - Deutsch

In diesem Handbuch werden die folgenden Symbole verwendet, die wesentliche Funktionen hervorheben. Die Symbole haben folgende Bedeutung:



WARNUNG - Unterhaltungs und Wartungsverfahren müssen genau befolgt werden, da ein Nichtbeachten zu Personenschäden oder tödlichen Verletzungen führt.



ACHTUNG - Falls Unterhaltungs und Wartungsverfahren nicht genau beachtet werden, kann der Turbolader dadurch beschädigt oder zerstört werden.



AUSBAU bzw. **ZERLEGEN**.



EINBAU bzw. **ZUSAMMENBAU**.



INSPEKTION erforderlich.



Teil oder Baugruppe **REINIGEN**.



DIMENSION - oder **ZEITMESSUNG**.



Teil oder Baugruppe **ÖLEN**.



WERKZEUGGRÖSSE wird angegeben.



ANZUG auf vorgeschriebenes Drehmoment erforderlich.



Sicherstellen, daß die **AUSWUCHTMARKEN** an der Rotor-Baugruppe richtig ausgerichtet sind.



Elektrische **MESSUNG DURCHFÜHREN**.



Weitere Informationen an anderer Stelle bzw. in anderen Handbüchern.



Schutzkleidung muß immer getragen werden.



Deutet an, daß Teile schwer sein können.



Website-Verzeichnis mit Ihrem nächsten Holset-Händler.



Gehe zu Inhalt

Symbols - English

The following group of symbols have been used in this manual to help communicate the intent of the instructions. When one of the symbols appears, it conveys the meaning defined below.



WARNING - Serious personal injury or extensive property damage can result if the warning instructions are not followed.



CAUTION - Minor personal injury can result or a part, an assembly or the engine can be damaged if the caution instructions are not followed.



Indicates a **REMOVAL** or **DISASSEMBLY** step.



Indicates an **INSTALLATION** or **ASSEMBLY** step.



INSPECTION is required.



CLEAN the part or assembly.



PERFORM a mechanical or time **MEASUREMENT**.



LUBRICATE the part or assembly.



Indicates that a **WRENCH** or **TOOL SIZE** will be given.



TIGHTEN to a specific torque.



Ensure that the **BALANCE MARKS** on the rotor assembly are in alignment



PERFORM an electrical **MEASUREMENT**.



Refer to another location in this manual or another publication for additional information.



Please wear protective clothing at all times.



Indicates components may be heavy.



Website access to find your nearest Holset Agent.



Go to contents

Simbolos - Español

Los simbolos siguientes son usados en este manual para clarificar el proceso de las instrucciones. Cuando aparece uno de estos simbolos, su significado se especifica en la parte inferior.



ADVERTENCIA – Procedimientos de Mantenimiento o Servicio que al no seguirse resultarán en daños personales o pérdida de vida.



ATENCION – Procedimientos de Mantenimiento o Servicio que al no seguirse al pie de la letra, resultarán en el daño o la destrucción del turbosobrealimentador.



Indica un paso de **REMOCION** o **DESMONTAJE**.



Indica un paso de **INSTALACION** o **MONTAJE**.



Se requiere **INSPECCION**.



LIMPIESE la pieza o el montaje.



Ejecutese una **MEDICION** mec-nica o del tiempo.



LUBRIQUESE la pieza o el montaje.



Indica que se dar- una **LLAVE DE TUERCAS** o el **TAMAÑO DE HERRAMIENTA**.



APRIETESE hasta un par torsor especifico.



Ceriórese de que est-n alineadas las marcas de balance en el rotor.



EJECUTESE una **MEDICION** eléctrica.



Para información adicional refiérase a otro emplazamiento de este manual o a otra publicación anterior.



Favor de siempre llevar ropa protectora.



Indica que los componentes pueden ser pesados.



Acceso a Sitio Web para localizar su agente Holset más cercano.



Ir a la tabla de materias

Symboles - Français

Les symboles suivants sont utilisés dans ce manuel pour aider à communiquer le but des instructions. Quand l'un de ces symboles apparaît, il évoque le sens défini ci-dessous:



ATTENTION DANGER - Procédures de maintenance ou d'entretien qui, si elles ne pas observées correctement, auront pour résultat des lésions corporelles ou un décès.



MISE EN GARDE - Procédures de maintenance ou d'entretien qui, si elles ne sont pas observées strictement, auront pour résultat de causer des dégâts au turbocompresseur ou de conduire à sa destruction.



Indique une opération de **DEPOSE**.



Indique une opération de **MONTAGE**.



L'INSPECTION est nécessaire.



NETTOYER la pièce ou l'ensemble.



EFFECTUER une **MESURE** mécanique ou de temps.



GRAISSER la pièce ou l'ensemble.



Indique qu'une **DIMENSION DE CLE** ou **D'OUTIL** sera donnée.



SERRER à un couple spécifique.



S'assurer que les repères d'équilibrage sur l'ensemble de rotor sont alignés.



EFFECTUER une **MEASURE** électrique.



Se reporter à un autre endroit dans ce manuel ou à une autre publication pour obtenir des information plus complètes.



Il faut toujours mettre vêtements de protection.



Indique que les composants peuvent être lourds.



Accès au site Web pour trouver l'agent Holset le plus proche.



Aller au sommaire

Símbolos - Português

Os símbolos a seguir serão utilizados neste manual para facilitar a comunicação das instruções e seus significados estão descritos abaixo.



ATENÇÃO - Os procedimentos de Manutenção ou Serviços que não forem seguidos corretamente resultarão em ferimentos pessoais ou riscos de vida.



AVISO - Os procedimentos de Manutenção ou Serviço que não forem rigorosamente seguidos resultarão em danos ou destruição do carregador turbo.



Indica um passo de **DESMONTAGEM**.



Indica um passo de **MONTAGEM**.



Requer inspeção.



LIMPE a peça ou conjunto.



Requer Medição mecânica ou de tempo.



LUBRIFIQUE a peça ou o conjunto.



Indica necessidade de **APERTO**.



TORQUEAR de acordo com o especificado.



Assegure-se de que as **MARCAS DE BALANCEAMENTO** do conjunto eixorotor estejam alinhadas.



Requer medição **ELÉTRICA**.



Procure em outra seção deste manual ou em publicação para obter informações adicionais



Por favor, sempre utilize EPI (Equipamento de Proteção Individual)



Indica que os componentes podem estar pesados.



Visite o Website para encontrar o seu Agente Holset mais perto.



Vá para Conteúdo

Turbocharger Identification



Dataplate

Note

Dataplates will be fitted to the compressor housing (8). The information from the dataplate must be quoted for service and parts support.

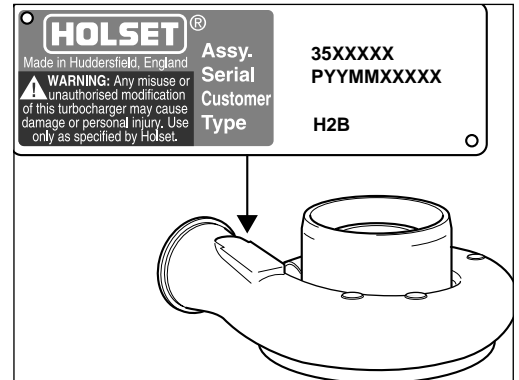

Center Housing Rotating Assembly (CHRA) (2)

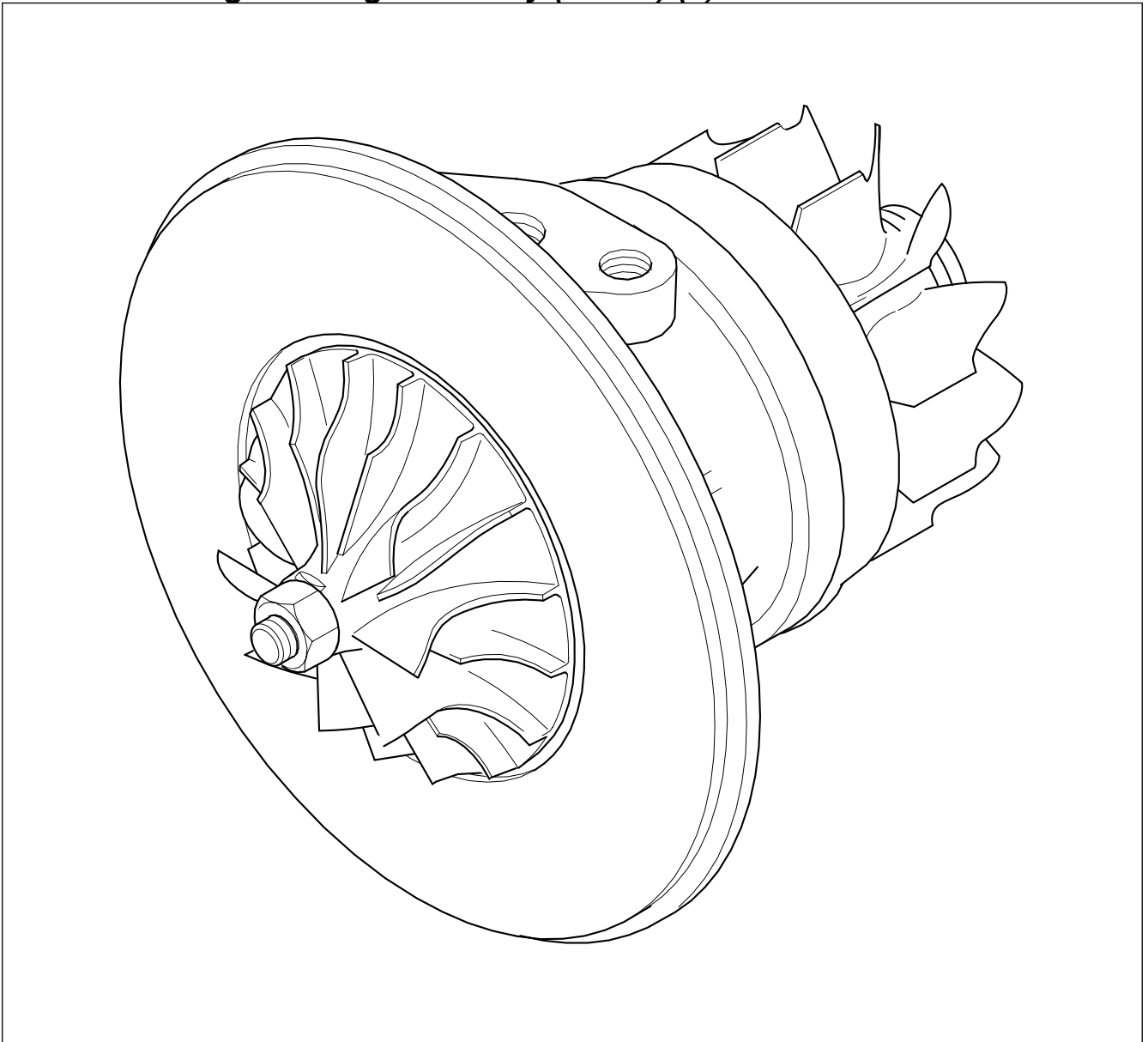

Exploded View - H2B (Lock plate option)

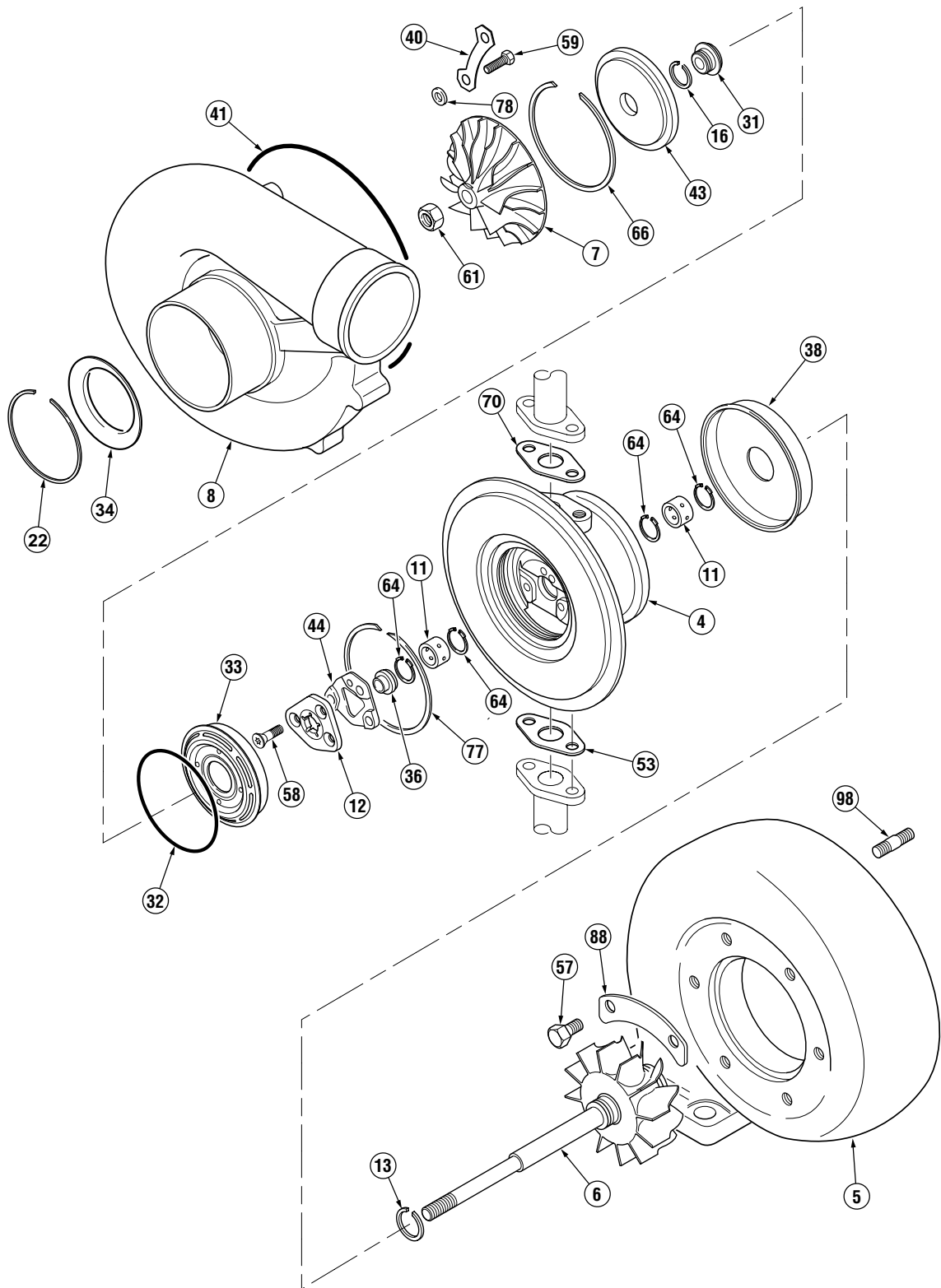

Note
Exploded views represent a generic build standard. Parts may be added or subtracted in specific applications.

Exploded View - H2C/D/S (Clamp plate option)

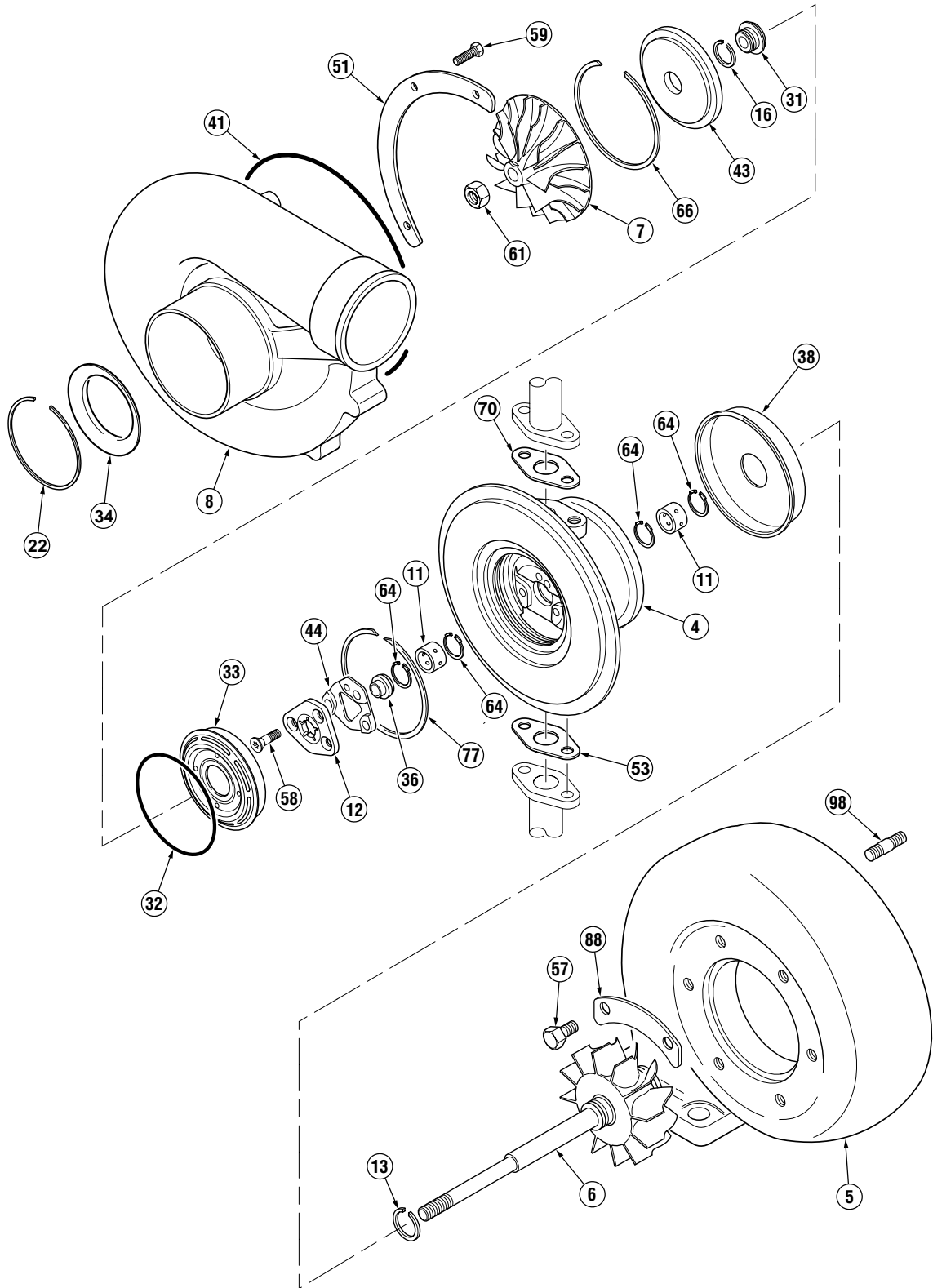

Note
Exploded views represent a generic build standard. Parts may be added or subtracted in specific applications.

Exploded View - H2E (V-Band option)

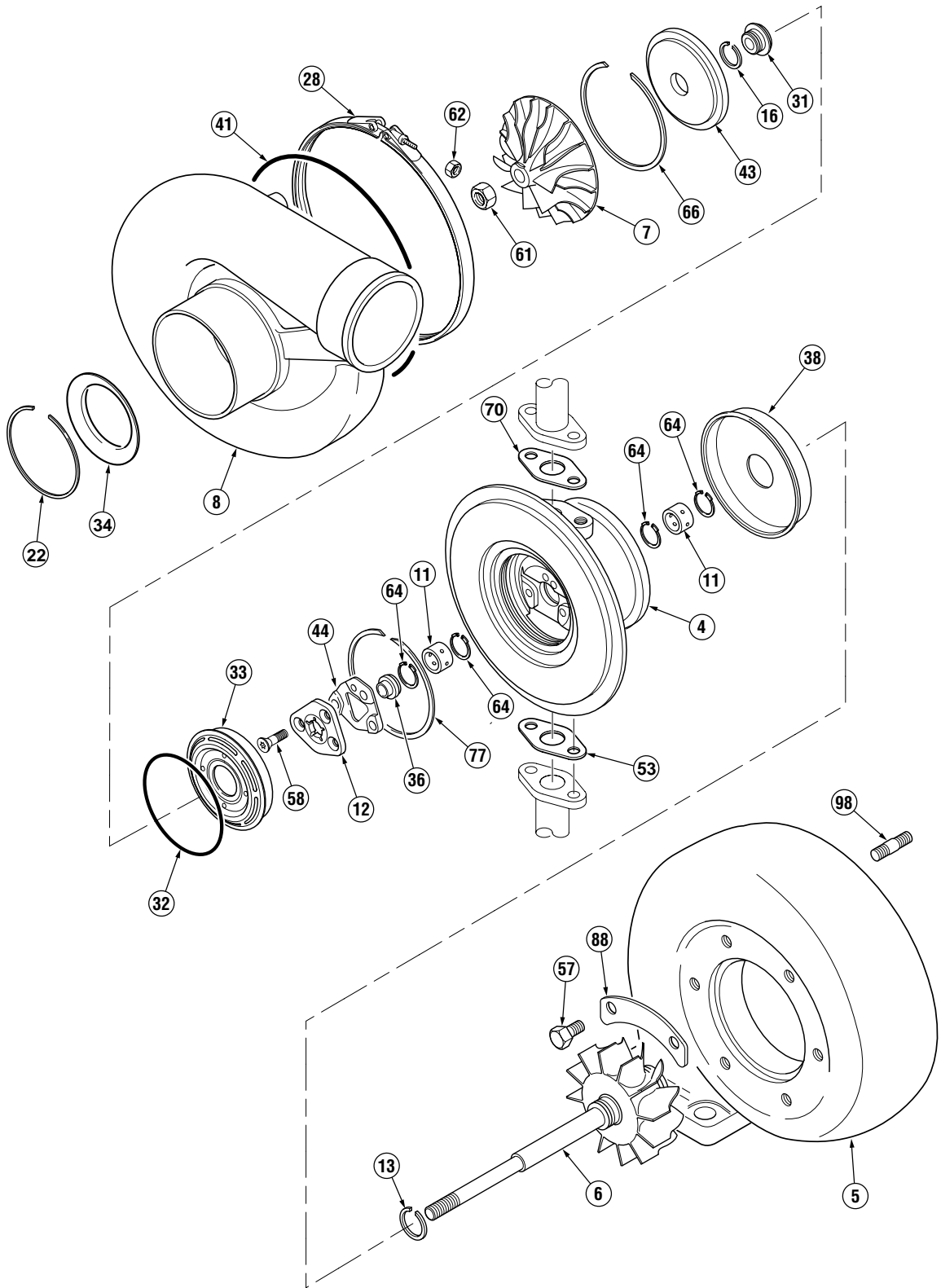

Note
 Exploded views represent a generic build standard. Parts may be added or subtracted in specific applications.

Component List



Item No.	Description	Quantity
1	Repair Kit CHRA (core)*	1
2	CHRA (Core)	1
4	Bearing Housing	1
5	Turbine Housing	1
6	Assembly, Turbine Wheel	1
7	Compressor Wheel	1
8	Compressor Housing	1
11	Journal Bearing*	2
12	Thrust Bearing*	1
13	Split Ring Seal, Turbine*	1/2
16	Split Ring Seal, Compressor*	1
22	Retaining Ring, Inlet Baffle	1
29	V-band Clamp, Compressor	1/0
31	Oil Slinger	1
32	O-Ring Seal, Bearing Housing*	1
33	Oil Baffle*	1
34	Inlet Baffle	1
36	Thrust Collar	1
38	Heat Shield	1
40	Lock Plate, Compressor	4/0
41	O-Ring Seal, Compressor Housing*	1
43	Oil Seal Plate	1
44	Spacer, Thrust Bearing	1
51	Clamp Plate, Compressor Housing	2/0
53	Gasket, Oil Outlet*	1
57	Bolt, Turbine Housing	6
58	Screw, Thrust Bearing	3
59	Bolt, Compressor Housing	8
61	Locknut, Compressor Wheel	1
62	Locknut, V-band*	1/0
64	Retaining Ring, Bearing*	4
66	Insert, Retaining Ring	1
70	Gasket, Oil Inlet*	1
78	Washer, Compressor	8/0
88	Clamp Plate, Turbine Housing	3
105	Connector male, Water	2
115	O-Ring Seal, Water	2

Note

Exploded views may not contain all listed components.

Purchasable Service Tools



Service Tools

The following special tools can be purchased from your local Authorised Repair Location. The use of these tools is recommended and where necessary they are shown in the appropriate service procedure.

Part No.	Tool Description	Tool Illustration
3575186	Circlip Pliers	
4027202	Wastegate Air Feed Adapter	
4027203	Wastegate Air Feed Adapter	
4027204	E-Clip Tool	

Caution

All Service and Maintenance settings are shown in Holset's Service Data Sheet. It is essential that these settings are used. Common tools found in mechanic's tool box not included.

Fault Finding chart



	Engine Running Hot	Poor Transient Response	Smoke	Engine Lacks Power	Black Exhaust Smoke	Blue Exhaust Smoke	High Oil Consumption	Turbocharger Noisy	Cyclic Sound from the Turbocharger	Oil Leak from Compressor Seal	Oil Leak from Turbine Seal
Dirty air cleaner Clean or replace element according to manufacturer s recommendations	●	●	●	●	●	●	●			●	
Restricted compressor intake duct Remove restriction or replace damaged parts as required	●	●	●		●	●	●	●	●	●	
Restricted air duct from compressor to intake manifold Remove restriction or replace damaged parts as required	●	●		●	●			●			
Restricted intake manifold Refer to engine manufacturer s manual and remove restriction	●	●		●	●			●			
Air leak in feed from air cleaner to compressor Replace seals, gaskets or tighten fasteners as required								●			
Air leak in feed from compressor to intake manifold Replace seals, gaskets or tighten fasteners as required	●	●	●	●	●	●	●	●			
Air leak between intake manifold and engine Refer to engine manufacturer s manual and replace gaskets or tighten fasteners as required	●		●	●	●	●	●	●			
Foreign object in exhaust manifold (from engine) Refer to engine manufacturer s manual and remove obstruction				●	●	●	●	●		●	
Restricted exhaust system Remove restriction or replace damaged parts as required	●			●	●					●	
Exhaust manifold cracked, gaskets blown or missing Refer to engine manufacturer s manual and replace gaskets or damaged parts as required		●	●	●	●			●			
Gas leak at turbine inlet/exhaust manifold joint Replace gasket or tighten fasteners as required		●	●	●	●			●			
Gas leak in ducting after turbine outlet Refer to engine manufacturer s manual and repair leak		●						●			
Restricted turbocharger oil drain line Remove restriction or replace damaged parts as required						●	●			●	●
Restricted engine crankcase breather Refer to engine manufacturer s manual, clear restriction					●	●				●	●
Turbocharger bearing housing sludged or coked Change engine oil and oil filter, overhaul or replace turbocharger as required					●	●				●	●
Fuel injection pump or fuel injectors incorrectly set Refer to engine manufacturer s manual and replace or adjust faulty components as required		●	●	●	●						
Engine valve timing incorrect Refer to engine manufacturer s manual for correct settings and adjust as required				●	●						
Worn engine piston rings or liners Refer to engine manufacturer s manual and repair as required				●	●	●	●			●	●
Burnt valves and/or pistons Refer to engine manufacturer s manual and repair as required				●	●	●	●			●	●
Excessive dirt build up on compressor wheel and/or diffuser vanes Clean in accordance with details in the appropriate Holset publication				●	●	●	●	●	●	●	●
Turbocharger damaged Find and correct cause of failure, repair or replace turbocharger as necessary				●	●	●	●	●		●	●

Service Tools



The following special tools are recommended to perform procedures in this manual. The use of these tools is shown in the appropriate procedure.

Part No.	Tool Description	Tool Illustration
	Torque Wrench	
	Dial Gauge and Dial Gauge Adaptor	

Caution

All Service and Maintenance settings are shown in Holset's Service Data Sheet. It is essential that these settings are used. Common tools found in mechanic's tool box not included.

On Engine Checks



Oil Leakage

Flange fitting M8 x 1.25

Warning The oil inlet is pressurised and no service action should be taken with the engine running.

Replacement gaskets, seals and adapters should be fitted without sealant as this can contaminate the oil. Torque tighten adapter to value shown in [Service Data Sheet](#) and flange fasteners to value specified by engine manufacturer.

It is important to avoid kinked pipes during servicing and subsequent operation.

Flange fitting M8 x 1.25

Warning Outlet oil is hot and no service action should be taken with the engine running.

Replacement gaskets and flange fasteners should be fitted without sealant as this can contaminate the oil. Torque tighten fasteners to value specified by engine manufacturer.

All outlet pipes should be free flowing without kinks and sharp bends and decline at an overall angle not less than 30° below the horizontal.

Closed crankcase ventilation systems have a tendency to deposit oil in the compressor housing. Where practical remove intake system pipework every 50,000 km (30,000 miles) to check housing, compressor wheel and inlet baffle condition.

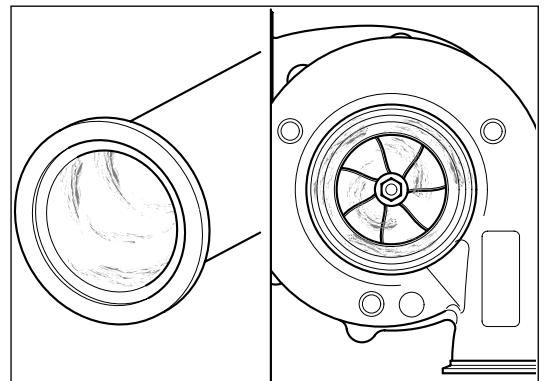
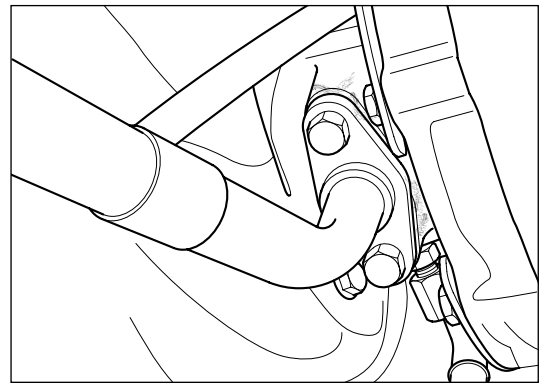
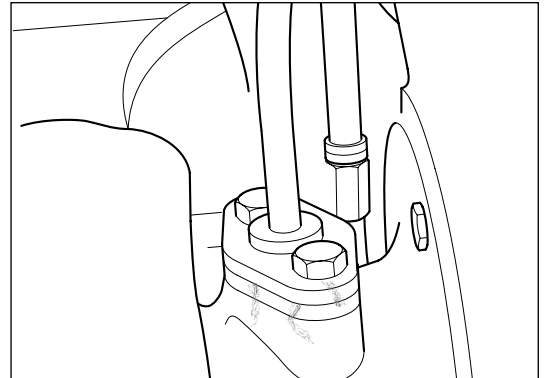

Always refer to [Cleaning of Housings](#) to clean housing. Rotor components can be cleaned using a non metallic bristle brush.

Warning Always wear safety glasses during cleaning.

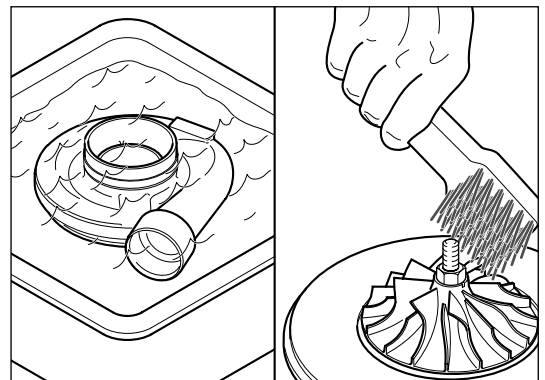
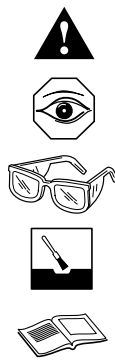



Exhaust Gas Leakage

Turbine housing flange leakage will cause soot formation on the flange. Check exhaust manifold to flange seal ensuring fastener torque meets engine manufacturer's recommendation.

Check flange for cracks.

Check Marmon and half Marmon connections (turbine outlet to exhaust system) for fretting damage. Where turbine housing damage is visible change housing.

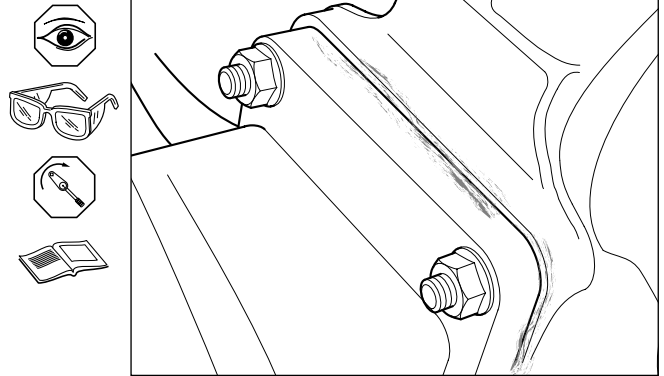

Coolant Leakage

M16 x 1.5

Repair by replacement of coolant inlet and outlet fittings. Where housing threads are damaged replace turbocharger. Torque tighten adapters to value specified by engine manufacturer.

Caution Do not use sealant as this may affect performance of o-ring seals.

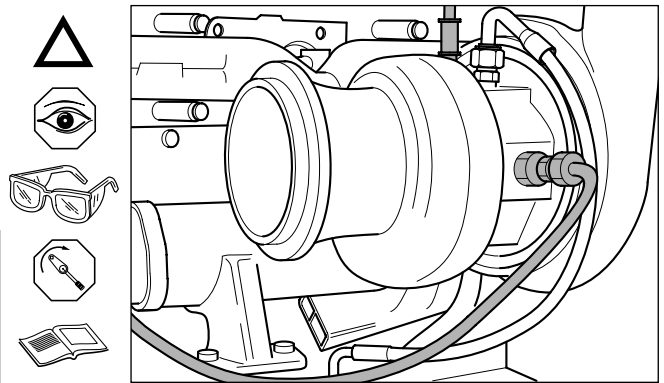

Visual Checks

Check for cracked, bent or damaged compressor wheel blades.

Caution Never attempt to straighten blades.

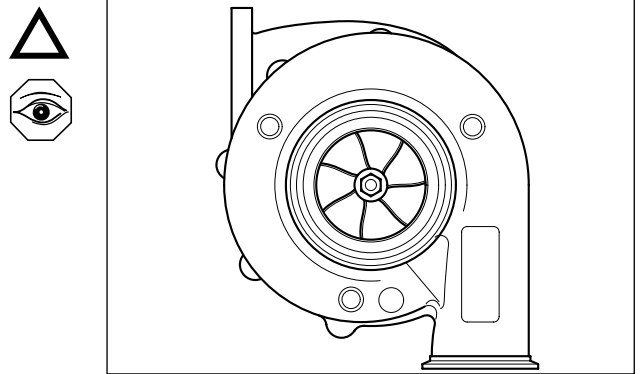

Where practical, check for cracked, bent or damaged turbine wheel blades.

Caution Never attempt to straighten blades.

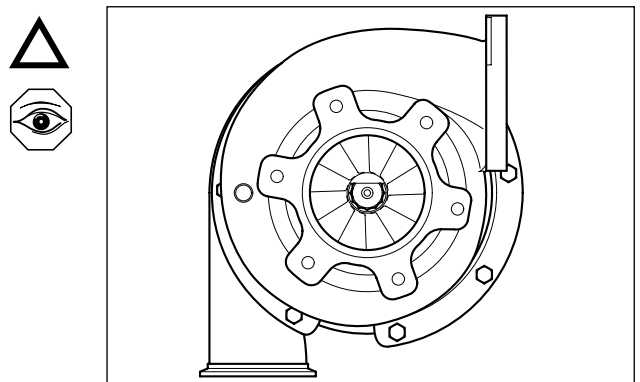



With intake system disconnected from compressor housing, it may be possible to check visually for excess bearing axial and radial clearances.

If in doubt, the turbocharger must be removed from engine to check bearing clearance against recommended values shown in [Service Data Sheet](#).

Note
Some turbochargers have a coating applied to the internal surface of the turbine housing. This special coating is abraded by the turbine wheel and may affect the bearing clearances until its unique form is fully formed.

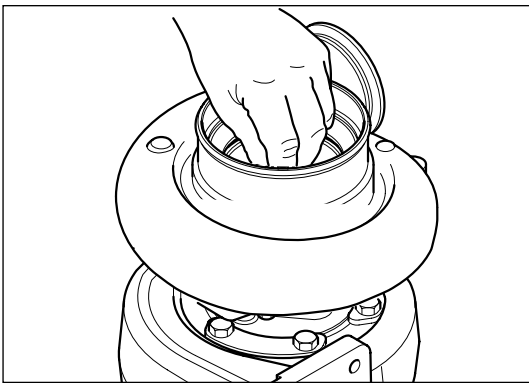

Bearing Clearance



Secure the turbine housing and check the axial clearance using a dial gauge.

Ensure clearance is within MIN/MAX values shown on [Service Data Sheet](#).

If axial clearance does not meet specification refer to turbocharger [Service and Overhaul](#) to strip and rebuild the CHRA (core).

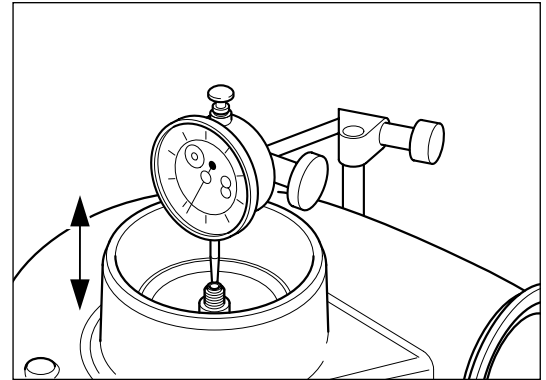

Check the radial movement at compressor impeller nose using a dial gauge.

Ensure movement is within MIN/MAX TIR (Total Indicator Reading) values shown on [Service Data Sheet](#).

If radial movement does not meet specification refer to turbocharger [Service and Overhaul](#) to strip and rebuild the CHRA (core).

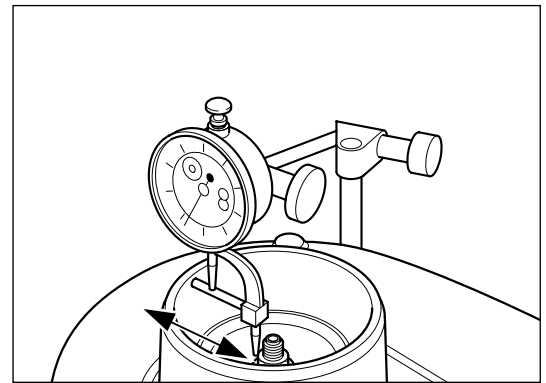

Turbine and Compressor Housings



Turbine Housing

Place turbine outlet on a clean flat surface. Mark turbine housing and bearing housing. This action assists in the re-assembly process defining correct component orientation.

Warning Always wear safety glasses.

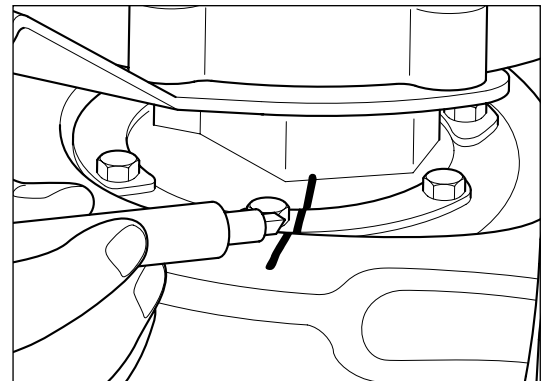

M8 x 1.25 (13 mm)

Secure turbine housing flange in vice.

Caution Take care not to shear the clamp plate bolts.

Seized bolts may be freed by spraying with penetrating oil and soaking for twenty minutes or a period of time recommended by the oil manufacturer.

Loosen and remove the six bolts and three clamp plates.

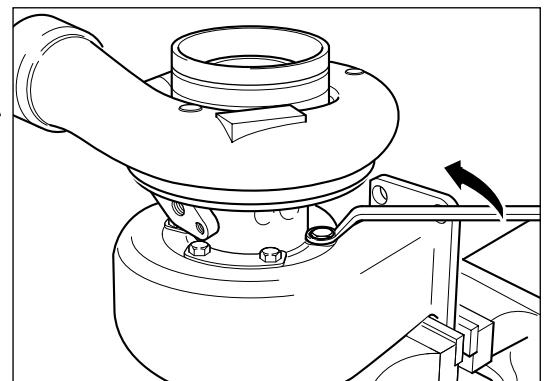
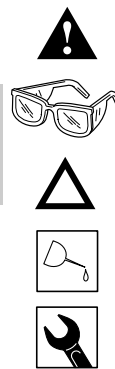

Using a soft hammer, tap turbine housing down against soft bench surface. As bearing housing and compressor housing assembly comes loose gently lift it out of turbine housing engagement

Caution Turbine blades can be damaged easily when the turbine housing is removed.

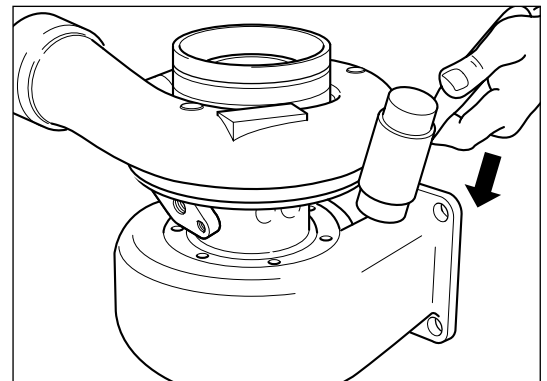
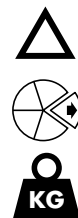

Caution Turbine housings can exhibit cracking when subject to excessive thermal and mechanical loads.

Cracking of the turbine housing inlet flange and inlet duct generally requires turbine housing replacement. Acceptance and rejection guidelines are shown in these illustrations. If an exhaust gasket is available, always ensure that any cracks lie within its sealing area.

Check turbine housing inlet flange flatness is within 0.1 mm (0.004 in) before retaining component for re-use.

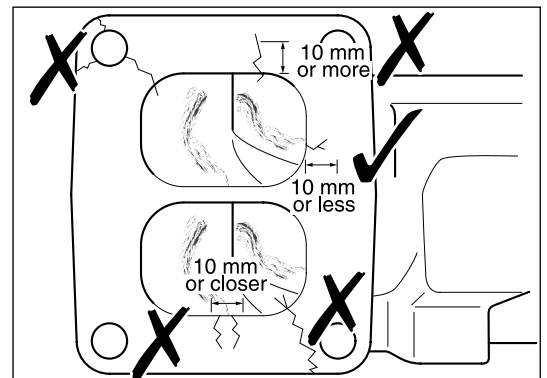



Flange Fasteners - Clearance Holes

Check fastener hole diameter is not more than 1.5 mm larger than the max. thread diameter of the fastener.

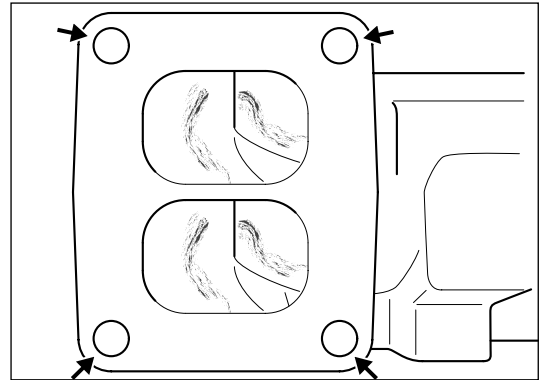

Flange Fasteners - Threaded Holes

M10 x 1.5

Check flange threaded holes with an M10 x 1.5 thread gauge.

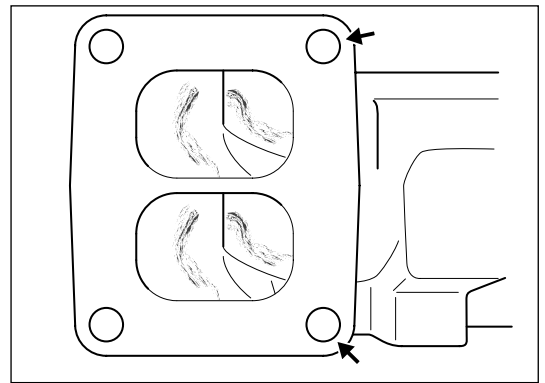

Caution  Where a crack will cause leakage to atmosphere the turbine housing must be replaced.

Cracking of the internal wall at the entry to the turbine wheel (tongue) is an acceptable service condition and the turbine housing may be re-used.

Always clean the turbine housing before re-assembly paying particular attention to surfaces close to the turbine wheel and the bearing housing location. Refer to [Cleaning of Housings](#) for details.

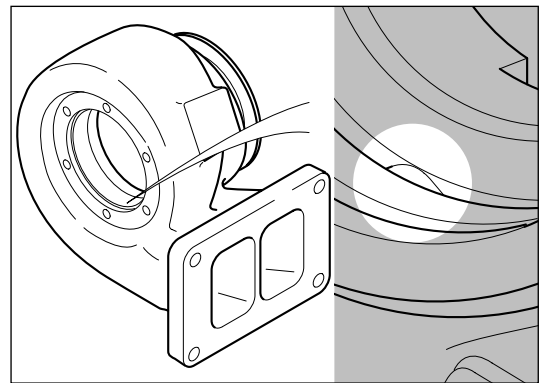

To replace turbine housing apply anti seize compound to bearing housing locating bore of the turbine housing.

Carefully slide bearing and compressor housing assembly into turbine housing. Use ink alignment mark to locate housing assembly in correct orientation with the turbine housing.

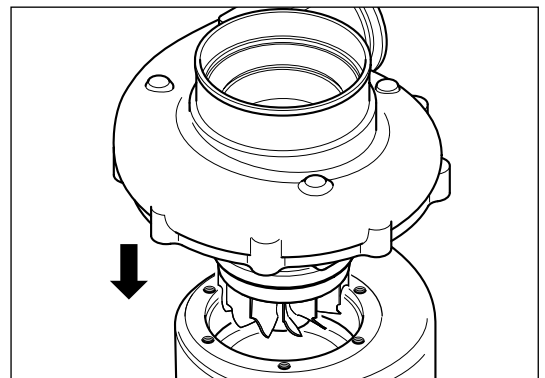

Caution  The turbine blades can be easily damaged when installing in the turbine housing



M8 x 1.25 (13 mm)

Secure turbine housing flange in vice.

Install the three clamp plates and torque tighten the six bolts to value specified in **Service Data Sheet**.

Depending on housing orientation, some clamp plate bolts may have restricted access. In these cases, use a suitable torque wrench adapter attached to a specially calibrated torque wrench.

Warning  Always wear safety glasses.

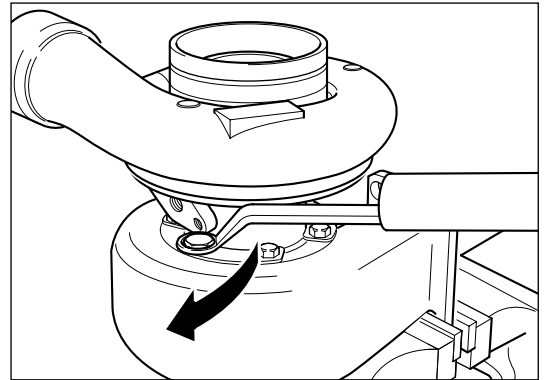
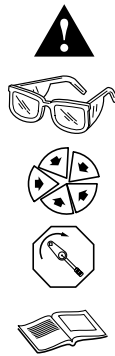

Ensure rotor assembly freely rotates.

Note
Some turbochargers have a coating applied to the internal surface of the turbine housing. This special coating is abraded by the turbine wheel and may affect turbocharger rotation until its unique form is fully formed.

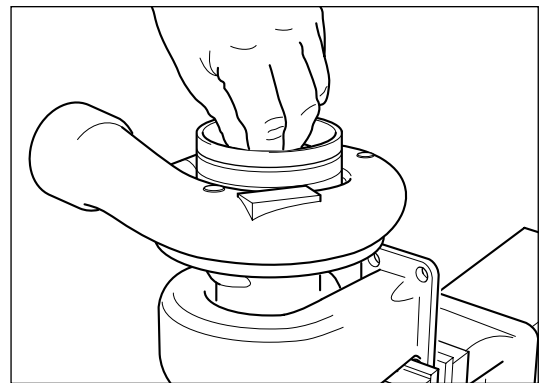

Compressor Housing

Place turbine outlet on a clean flat surface. Mark compressor housing, bearing housing and V-band clamp, compressor (where fitted) to record correct orientation. This action assists in housing orientation during re-assembly.

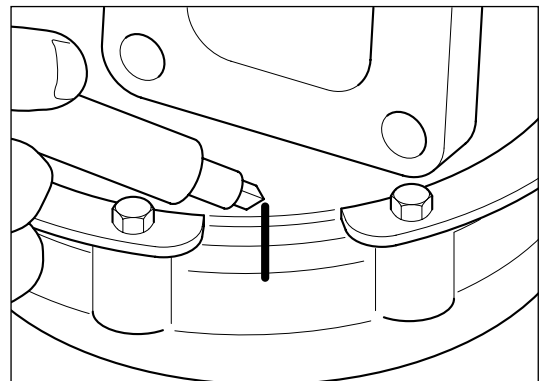

V-Band Option

Remove locknut, v-band and discard.

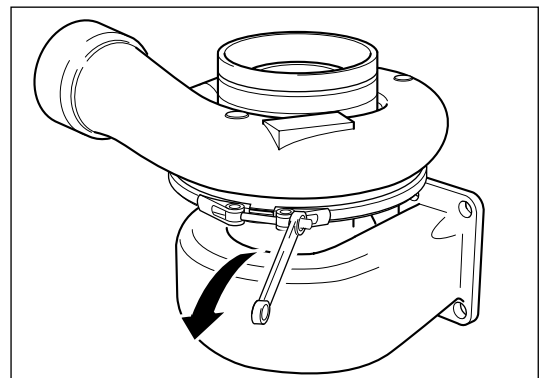



Lock Plate Option

M6 x 1.25 (10 mm)

Use a hammer and drift to knock lock plate tabs away from compressor housing bolts.

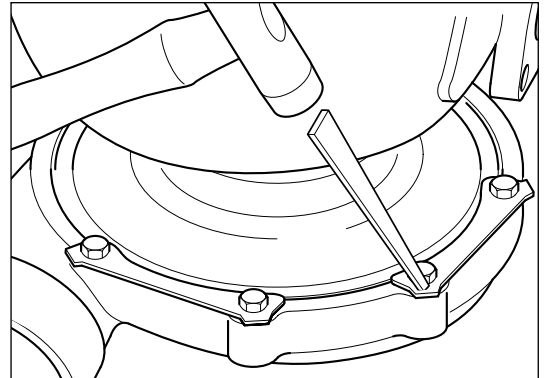

Clamp Plate/Lock Plate Option

M6 x 1.25 (10 mm)

Secure turbine housing flange in vice.

Seized bolts may be freed by spraying with penetrating oil and soaking for twenty minutes or a period of time recommended by the oil manufacturer.

Caution Take care not to shear bolts.

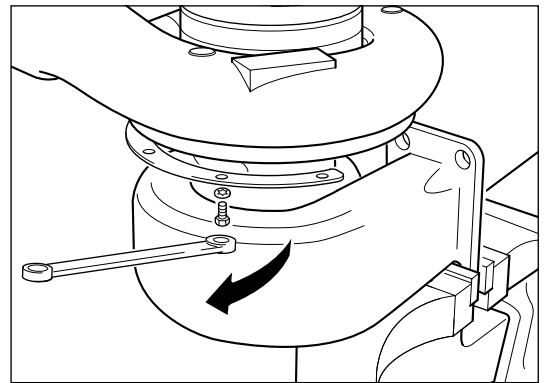

Loosen and remove the six bolts and three clamp plates.

Caution Compressor blades can be damaged easily when the compressor housing is removed.

Use a soft hammer to gently tap the compressor housing off the bearing housing.

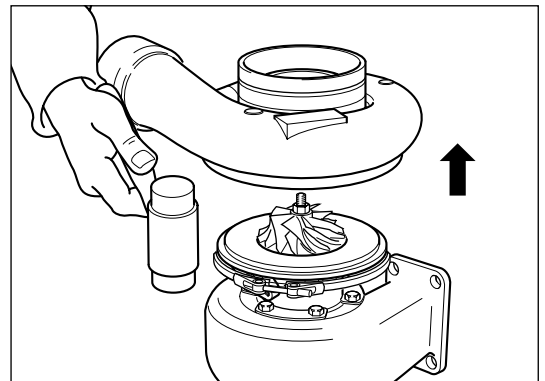
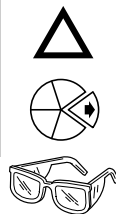

The bearing housing to compressor housing joint is fitted with o-ring seal, compressor (41). This seal should be removed and discarded at this stage.

Caution Always fit a new seal on re-assembly.

The seal may be seated in the compressor housing or bearing housing dependent on the turbocharger model.

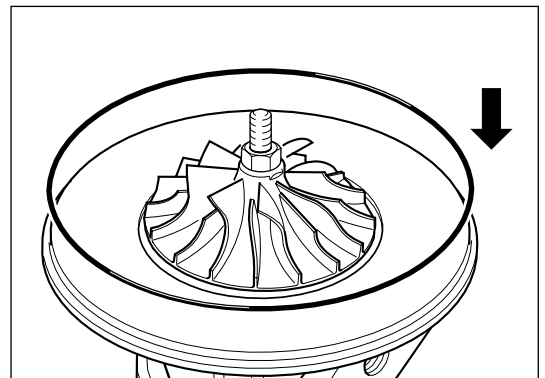
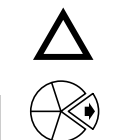



Inspect internal profile of compressor housing for scoring damage due to possible contact with compressor wheel. Move to **Cleaning of Housings** if deposits remain.

Replace with new if profile damage is visible.

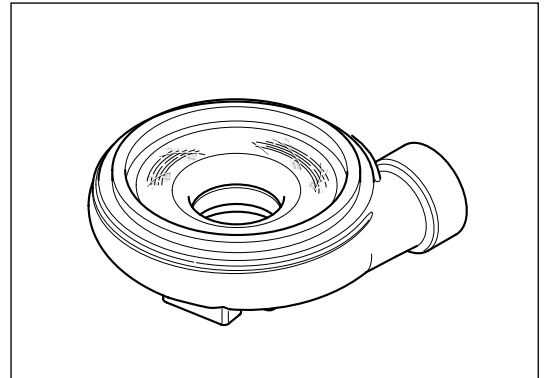
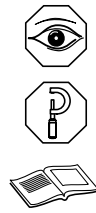

Inlet baffle option

To clean compressor housings fitted with an inlet baffle it is necessary to remove baffle.

Inlet baffle (A) is the old type; inlet baffle (B) is the new type. Baffle (B) has been improved and no longer incorporates the four stepped areas. This gives the new baffle increased service life.

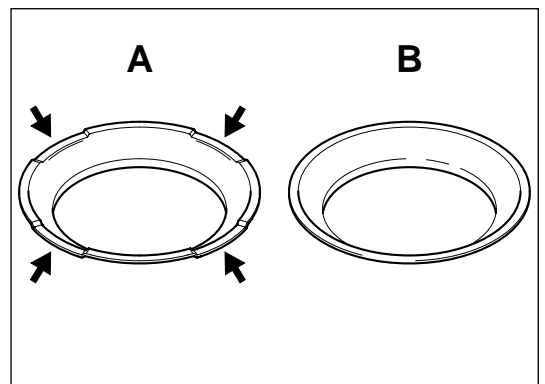

Caution Always fit the new type of baffle (B) on re-assembly.

Caution When removing the inlet baffle retaining ring, be careful not to damage the compressor wheel with the screw driver. Use a rag or rubber bung to protect the wheel.

Using a flat screw driver, carefully apply force in the area shown (C) as the retaining ring starts to move, force the screwdriver under the ring as shown in (D).

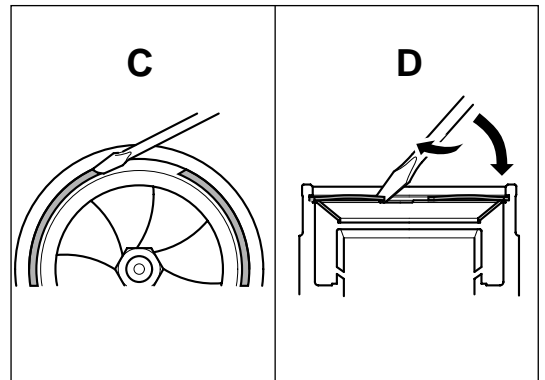

Warning Always wear safety glasses.

Push the screwdriver in an anti-clockwise (counter-clockwise) direction to force the retaining ring out of the groove. Remove the retaining ring.

Remove the inlet baffle.

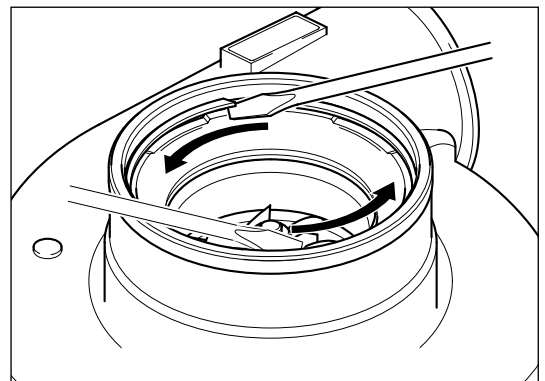



Following cleaning of the compressor housing, locate a new type of inlet baffle onto the location ledge of the compressor housing inlet.

Warning  Always wear safety glasses.

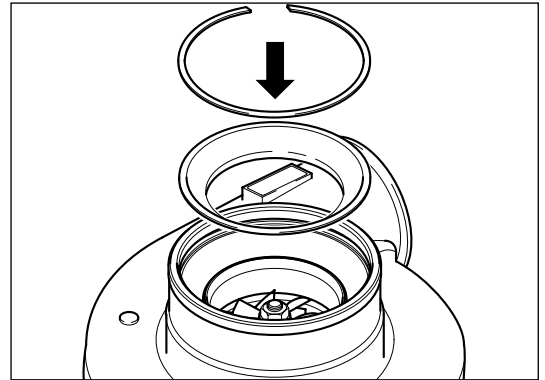

Hold one end of the retaining ring in position in its compressor cover groove. Press the remainder of the retaining ring into position using free hand.

Use a flat screw driver to make sure the retaining ring is correctly seated in the compressor cover groove.

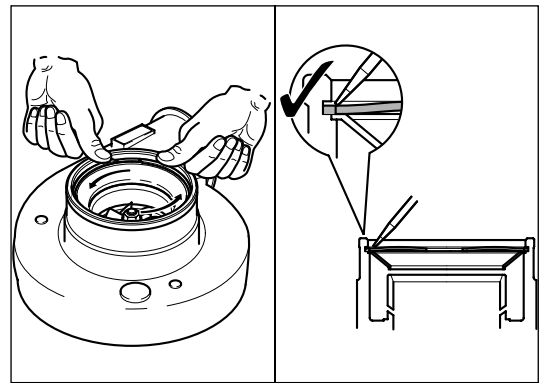

Place the turbine and bearing housing assembly on a clean surface. To refit compressor housing, lubricate new o-ring seal with clean engine oil and install into retaining groove. Loosely fit v-band clamp (where fitted). Carefully locate the compressor housing over the compressor wheel.

Caution  The compressor wheel blades can be easily damaged when the CHRA is installed.

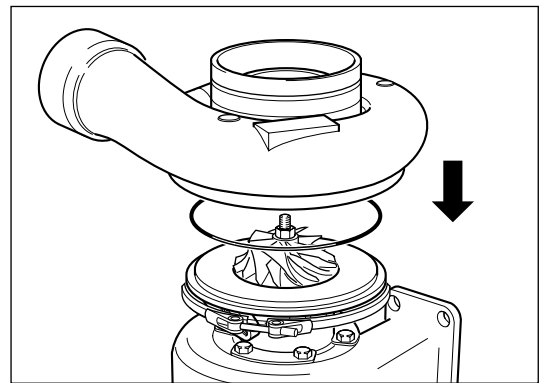

V-band Option

1/4 UNF 28 tpi (7/16 in)

Place v-band clamp in position and torque tighten new locknut to value specified in [Service Data Sheet](#).

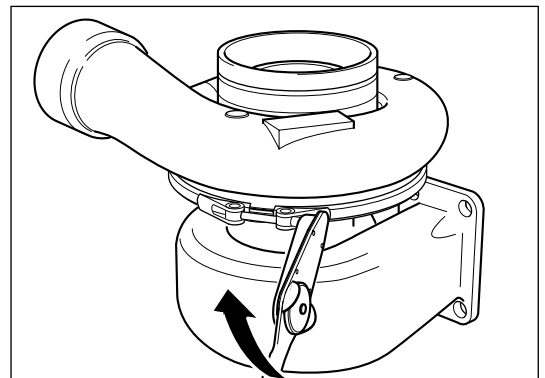
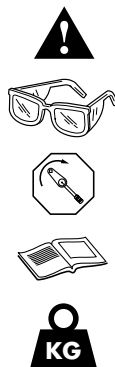



Clamp Plate/Lock Plate Option

M6 x 1.25 (10 mm)

Secure turbine housing flange in vice.

Install clamp plates/lock plates, washers (where fitted) and 8 bolts. Torque tighten bolts to value shown in [Service Data Sheet](#).

Warning  Always wear safety glasses.

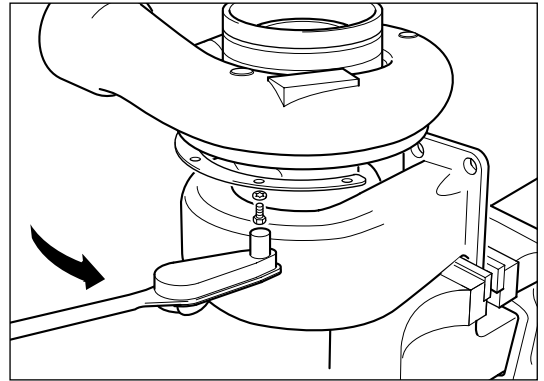
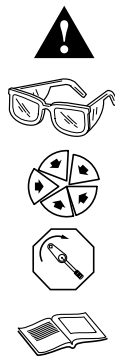

Lockplate Option

Place compressor inlet on a clean flat surface.

Use a hammer and drift to knock lockplate tabs into position against compressor housing bolts.

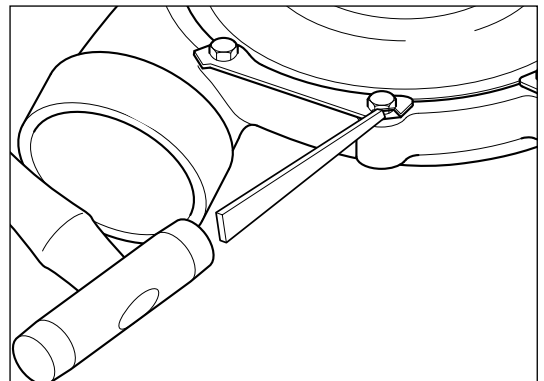

Ensure rotor assembly freely rotates.

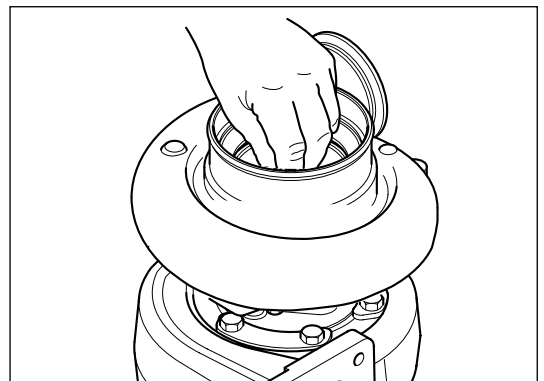



Cleaning of Housings

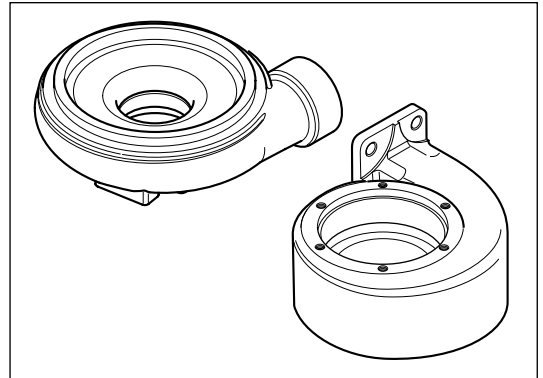

Visually inspect the parts to detect signs of burning and other conditions in order to obtain as much information as possible before washing.

Caution 
Housing surfaces adjacent to turbine and compressor wheels must be clean, smooth and free from deposits.



Warning 
Always wear safety glasses.

Soak the housings in a non-corrosive low flash point metal cleaner to loosen deposits.

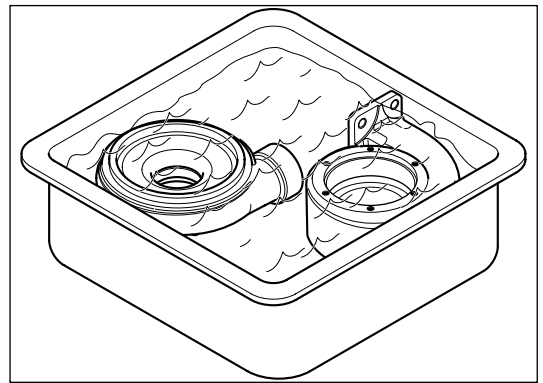

Dry the components using compressed air.

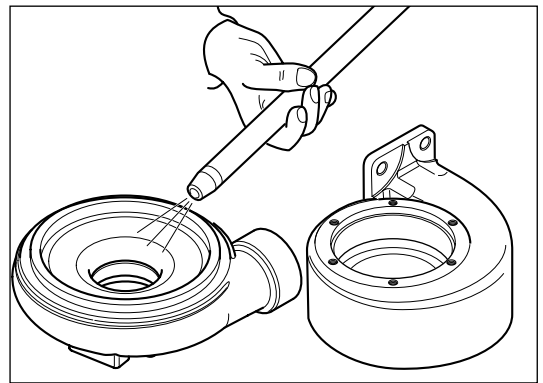
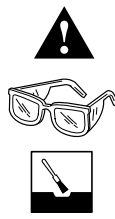

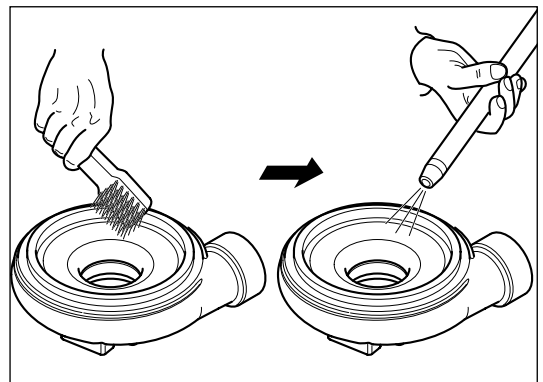
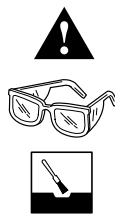

Scale like deposits, if any, must be removed by using a non metallic bristle brush. After removing the deposits, re-wash and dry the components.





It is permissible to bead blast the turbine housing if chemical and brush cleaning is not effective.

Warning 
Always wear safety glasses.

Warning 
Do not bead blast Aluminium and Cast Iron components together.

Caution 
Prevent the bead spray impinging directly on clamp plate and turbine flange threads by masking or plugging

After removing the deposits, re-wash and dry the components.

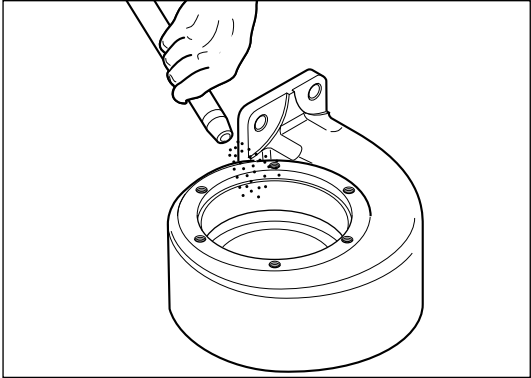

Service Tools



The following special tools are recommended to perform procedures in this manual. The use of these tools is shown in the appropriate procedure. These tools can be purchased from your local Authorised Repair Location.

Part No.	Tool Description	Tool Illustration
	Torque Wrench	
	Dial Gauge and Dial Gauge Adaptor	
3503071	T20 TORX®	

Caution

All Service and Maintenance settings are shown in Holset's Service Data Sheet. It is essential that these settings are used. Common tools found in mechanic's tool box not included.

Disassembly



Note
 Before disassembly, check for turbine and compressor blade damage. Measure bearing radial movement and axial clearance to ensure the CHRA (core) is within the MIN/MAX values shown on [Service Data Sheet](#).

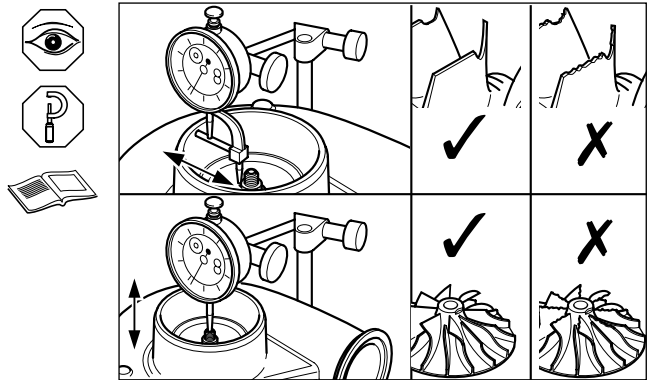

Locate the CHRA (2) on to a 19 mm 12 point socket located in a suitable fixture.

Caution 
 Always make sure the turbine wheel shaft and compressor wheel have alignment marks before disassembly of the CHRA.

If no marks exist scribe the shaft and compressor wheel before removing the compressor wheel lock nut. The washing process may remove indelible ink so a file mark on the shaft and scribe line on the compressor wheel nose is recommended.

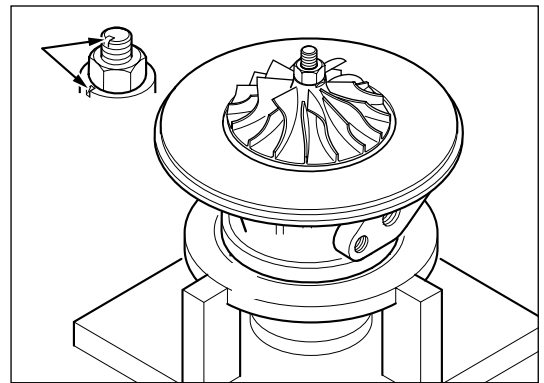
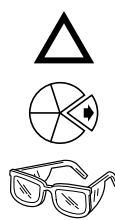

M8 L.H. (13mm)

Remove the locknut, compressor wheel (61).

Warning 
 Always wear safety glasses.

Note
 Left hand thread.

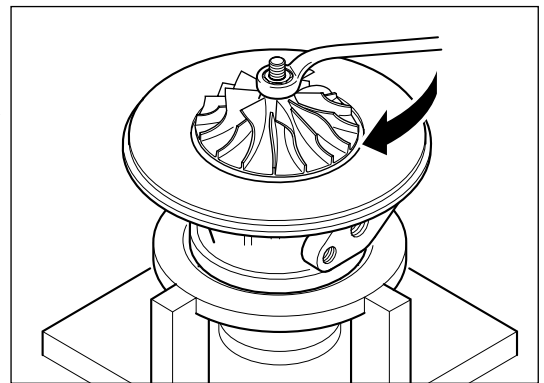
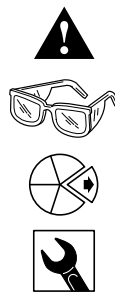

Remove compressor wheel (7).

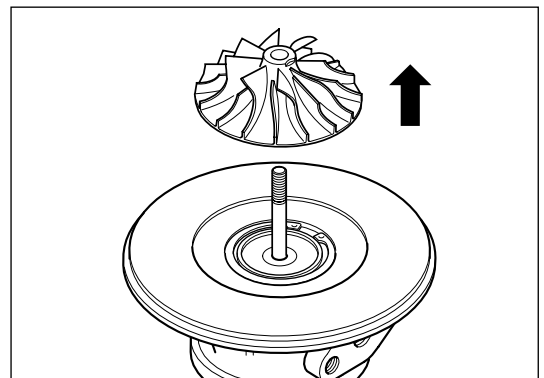



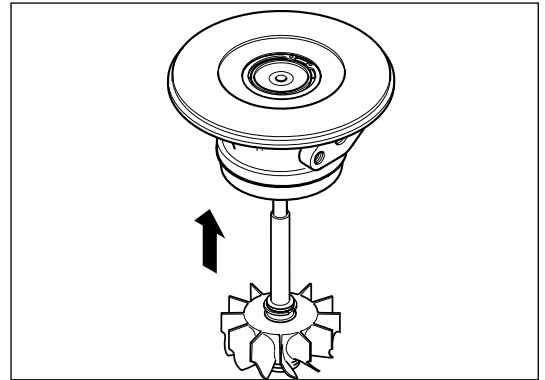

Remove remaining CHRA from fixture and gently slide bearing housing (4) off the assembly turbine wheel (6).
It is permissible to tap the protruding turbine shaft gently with a soft hammer if the split ring seal/s are stuck in their bore.



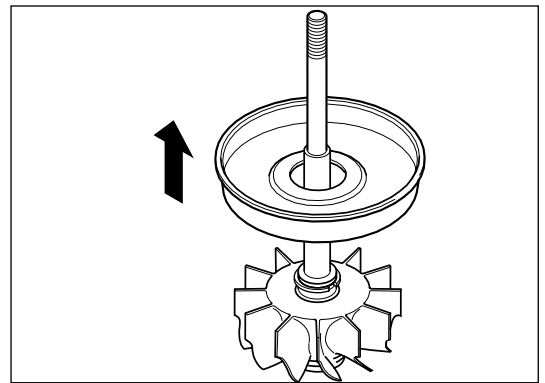

Remove heat shield (38).

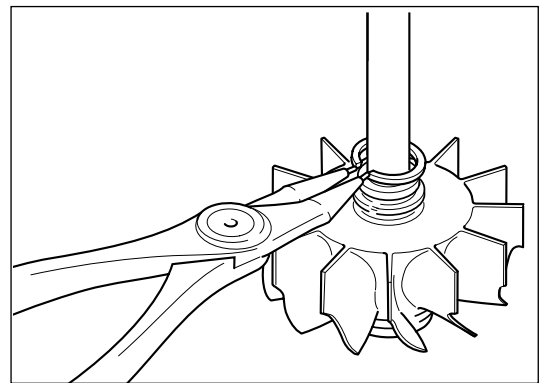

Carefully remove the split ring seal / seals, turbine (13) * and discard.

Warning 
Always wear safety glasses.



Caution 
Care should be taken not to score the turbine wheel shaft assembly.

With bearing housing (4) on a flat clean surface, use suitable circlip pliers to remove insert, retaining ring (66).
It is practical to use free hand to contain disassembled ring whilst releasing pliers.

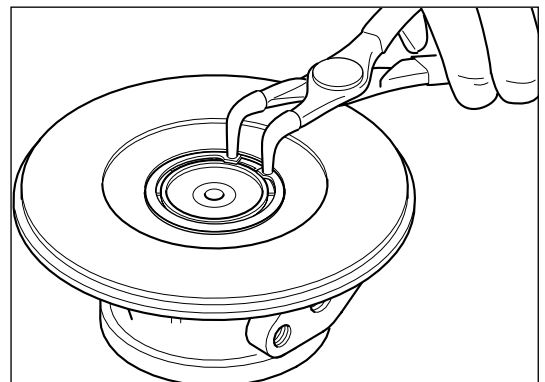



Retaining Ring Option

Remanufactured turbochargers may be fitted with an alternative retaining ring.

To remove, locate a precision screwdriver behind the angled end of the ring. Prise the end out of the groove and, using a rotary motion, progressively lift the ring from the groove.

Warning  Always wear safety glasses.

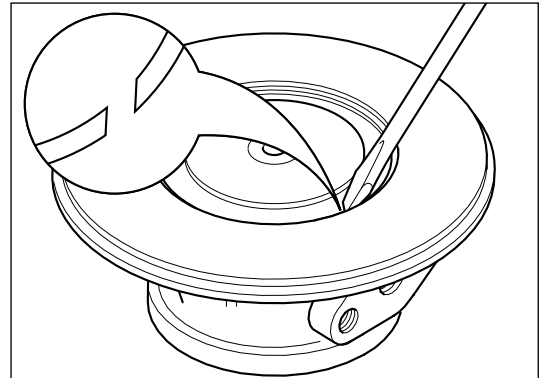

Using two flat screwdrivers, gently remove the oil seal plate (43)

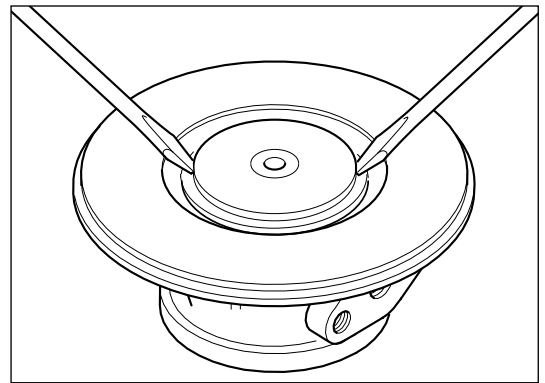

Remove oil slinger (31).

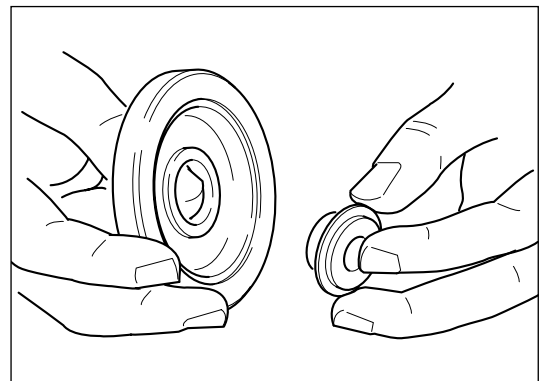

Using piston ring expander pliers remove and discard split ring seal, compressor (16) * from oil slinger.

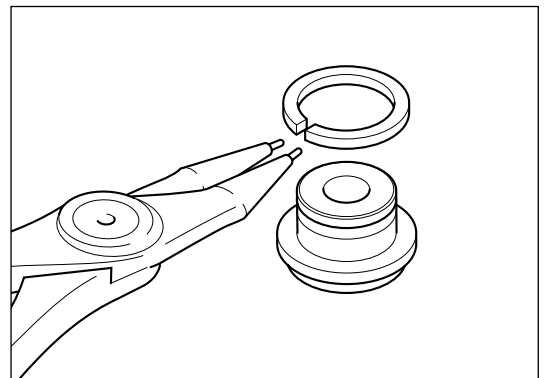



Remove the o-ring seal, bearing housing (32) * and discard.

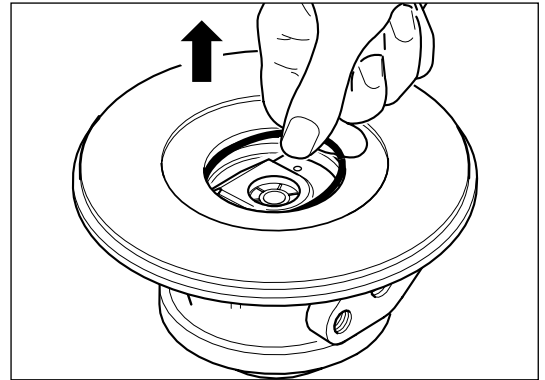

Remove oil baffle (33) * and discard.

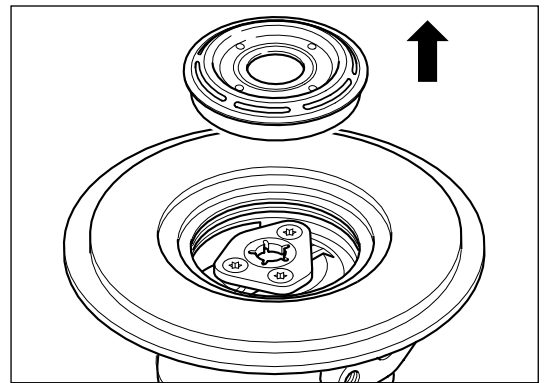

T20 TORX®

Using a T20 Torx bit, remove the 3 flat head screws (58) * and discard.

Warning

Always wear safety glasses.

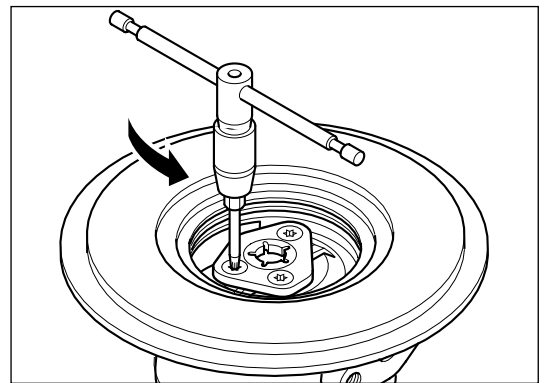

Remove the thrust bearing (12) * and discard.

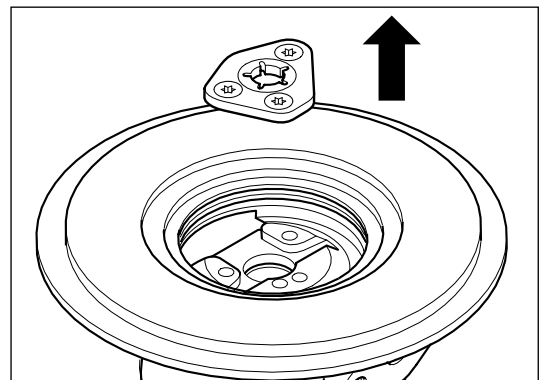



Remove the thrust collar (36).

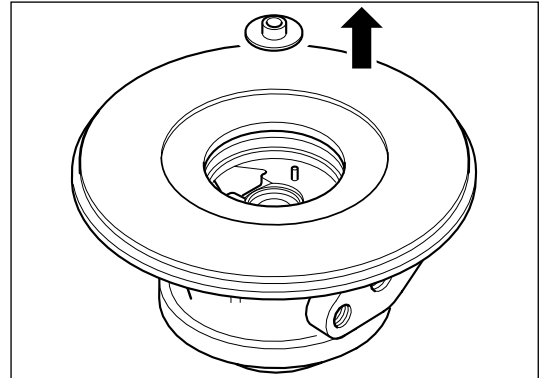

Warning  Always wear safety glasses.

Using circlip pliers, Part No. 56664, remove the two circlips (64) * and the journal bearing (11) * from the compressor end and discard.

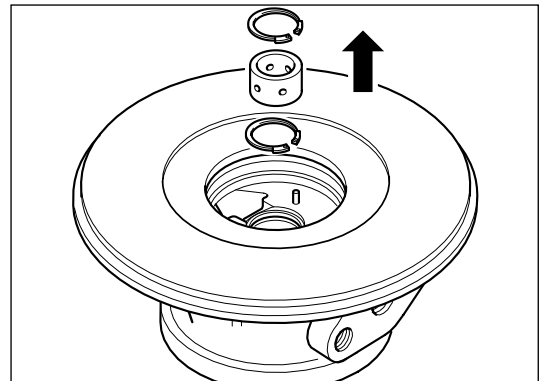

Turn the bearing housing over and repeat the process of bearing removal at turbine end.

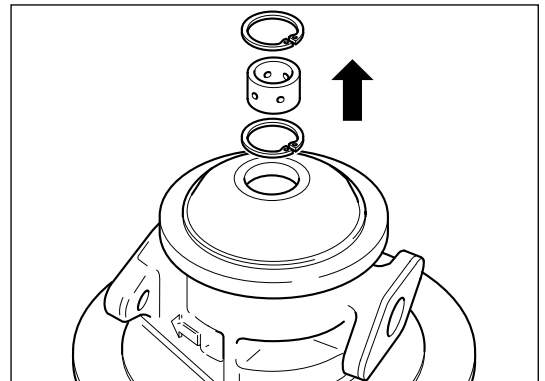
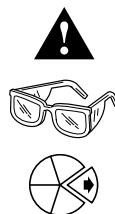

Compressor Inlet Baffle (option)

Where specified by the engine manufacturer, certain turbochargers can have a pressed steel baffle fitted into the inlet section.

This item is not serviceable and if damaged, must be replaced, as the geometry of the part is critical to the performance of the baffle.

To clean compressor housings always remove inlet baffle.

Refer to [Turbine and Compressor Housings](#) for removal instructions.

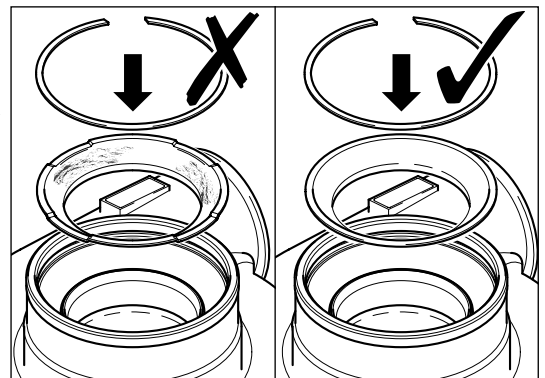
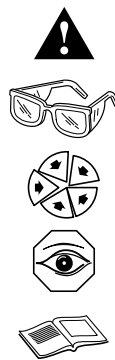

Warning  Always wear safety glasses.

Component Cleaning



Visually inspect all parts to detect signs of burning and other fault conditions in order to obtain as much information as possible before washing.

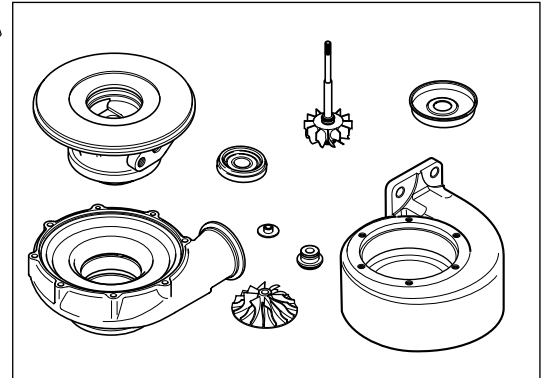
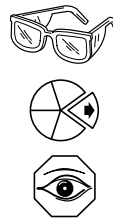

Soak the components in a non-corrosive low flash point metal cleaner to loosen deposits.

Warning  Always wear safety glasses.

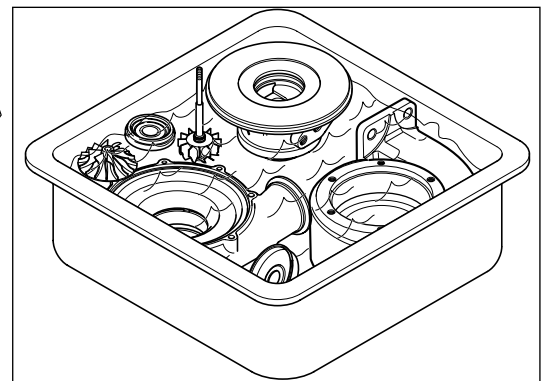

Dry the components using compressed air.
Protect the sliding surfaces of the cleaned parts against corrosion by applying clean engine oil.

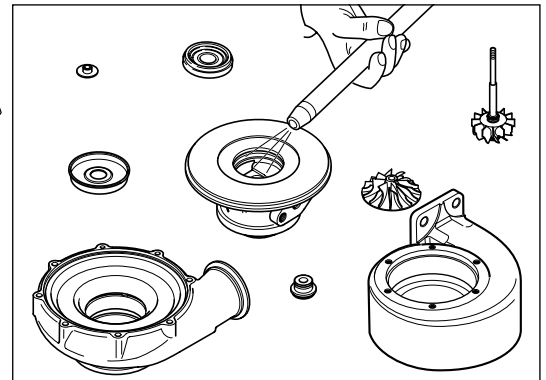

M6 x 1.25
Scale like deposits, if any, must be removed by using a non metallic bristle brush. After loosening the deposits with the brush, wash and dry components as above.
Clamp plate threads can be cleaned using the specified thread gauge.

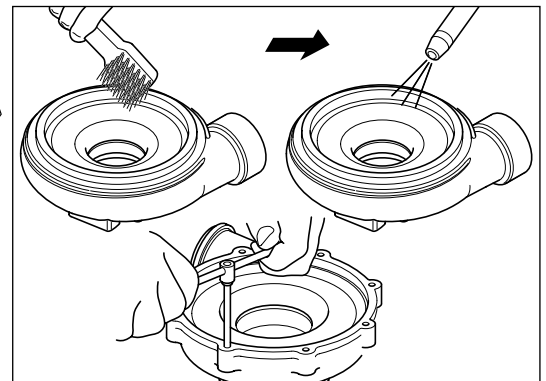
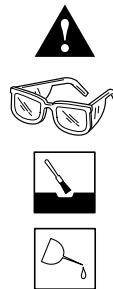



Exhaust Flange M10 x 1.5, Exhaust Outlet M8 x 1.25
 Clamp Plate/Lock Plate M8 x 1.25

Warning

Do not bead blast Aluminium and Cast Iron components together.

It is permissible to bead blast the turbine housing if chemical and brush cleaning is not effective.

Caution

Housing surfaces adjacent to turbine and compressor wheels must be clean, smooth and free from deposits. Always protect threads during bead blasting and clean with the specified thread tap after blasting.

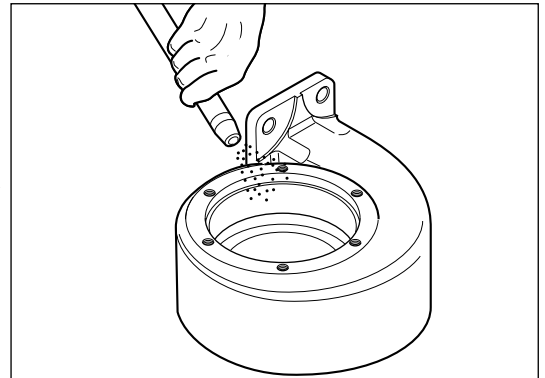

Oil fittings M8 x 1.25

Coolant fittings M16 x 1.5

It is important that the oil chamber of the bearing housing is free of carbon before re-building. If heavy deposits persist after repeat washing replace bearing housing (4).

Caution

Do not bead blast the bearing housing as this may damage critical bearing surfaces.

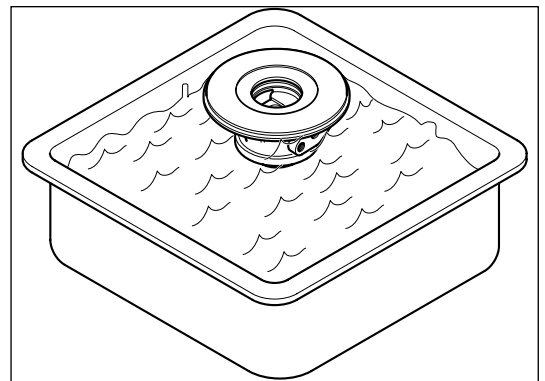

It is permissible to bead blast steel rotating parts.

Caution

Blasting specific areas for long periods of time may affect component balance. Protect thread of turbine wheel assembly.

Caution

Always clean components with compressed air after blasting.

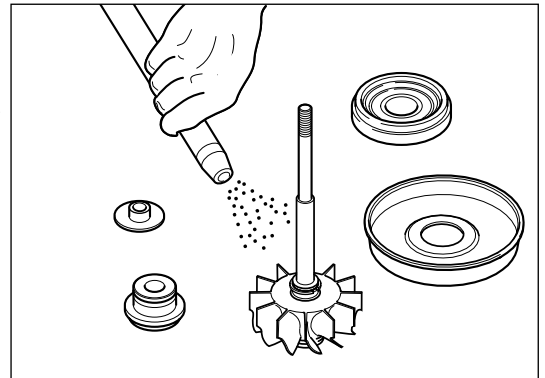

Warning

Always wear safety glasses.

Caution

Do not bead blast the Aluminium compressor housing as this may damage critical surfaces.



Inspection and Testing



Major Components

Assembly Turbine Wheel

Place assembly, turbine wheel (6) on a vee block. Position a dial gauge on the turned surface of the shaft at the threaded end. Check dial gauge reading. Where shaft bend is greater than the recommended maximum of 0.025 mm (0.001 in) replace the assembly.

Caution  Do not attempt to straighten the turbine shaft.

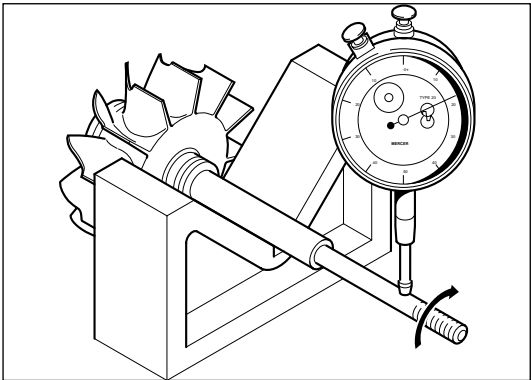

Inspect split ring seal, turbine (13)* groove walls for wear. If groove width exceeds recommended maximum replace assembly.

Single ring seal 1.69 mm (0.067 in)

Dual ring seal 3.55 mm (0.140 in)

If the wear step on the ring face exceeds 0.102 mm (0.004 in) replace split ring seal, turbine.

If the free gap of the ring is less than 2.0 mm (0.08 in) replace split ring seal, turbine.

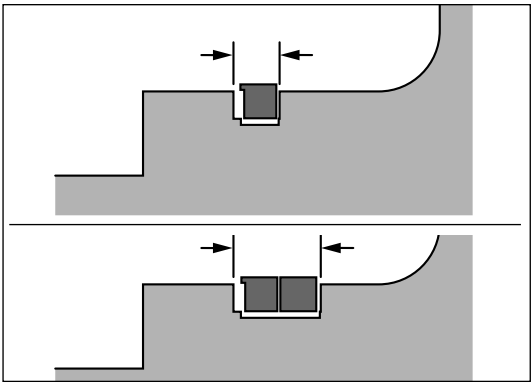

Inspect the bearing journals for excessive scratches and wear. Where scratching is excessive or where either journal diameter is less than the recommended minimum of 12.19 mm (0.48 in) replace the assembly.

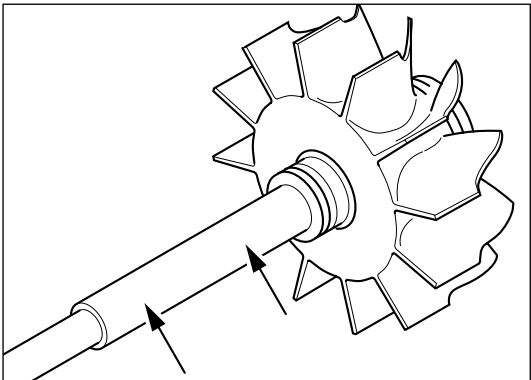

Inspect for cracked, bent or damaged blades.

Caution  Do not attempt to straighten blades.

Replace with new if any damage found.

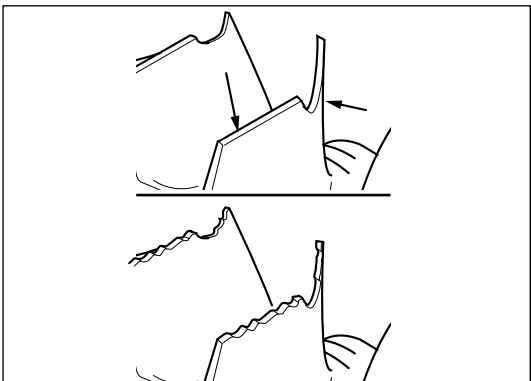



Compressor Wheel

Inspect compressor wheel (7), for cracked, bent or damaged blades.

Caution Do not attempt to straighten blades.

Replace with new if any damage found.

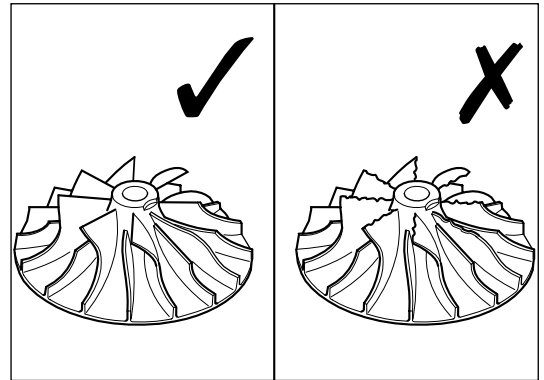

Compressor Housing

Inspect internal profile of compressor housing (8), for scoring damage due to possible contact with compressor wheel.

Return to **Component Cleaning** if deposits remain.

Replace with new if profile damage is visible.

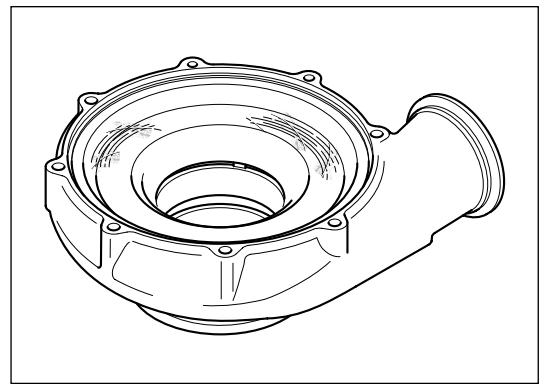

M6 x 1.25

Check clamp plate, compressor housing threads are clean. Ensure all threads are clean and use a thread gauge to check thread condition.

Replace with new if thread damage will adversely affect clamp loading.

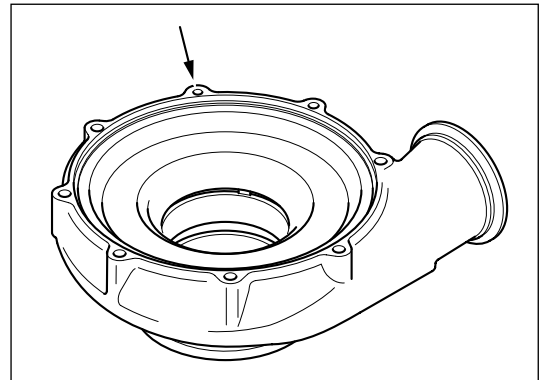

Turbine Housing

Clamp Plates M8 x 1.25

Turbine inlet/outlet connections M10 x 1.5

Inspect the turbine housing (5) profile for damage caused by possible contact with the rotor. Inspect the outer and internal walls for cracks or flaking caused by overheating.

Check turbine housing inlet flange flatness is within 0.1 mm (0.004 in). Check fastener hole diameter is not more than 1.5 mm larger than the max. thread diameter of the fastener. Where studs have been removed check flange threaded holes with the specified thread gauge. Ensure exposed threads are clean and check with appropriate thread gauge.

Replace with new if any of the above features are non compliant.

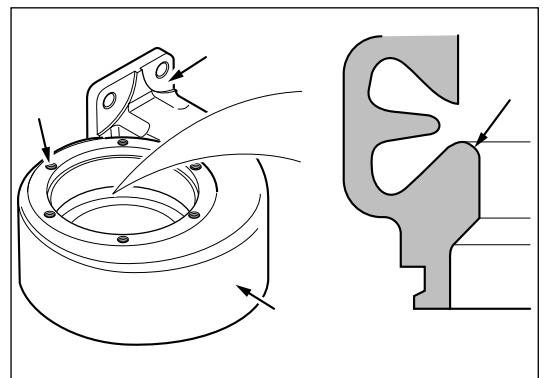



Air and Liquid Cooled Bearing Housings

Oil Flanges M8 x 1.25 - Oil Adapter M16 x 1.5

Inspect journal bearing bores for wear and score marks. Replace bearing housing (4) if a bore diameter exceeds a maximum of 19.06 mm (0.75 in) or when bore scratching is severe.

Ensure groove locations for retaining rings, bearing (64) are free from deposits and do not exceed width of 1.07 mm (0.042 in)

Check that the oil cavity is free from carbon and any entrained debris that may be the result of a failure. Ensure all oil port threads are clean then check with the appropriate thread gauge.

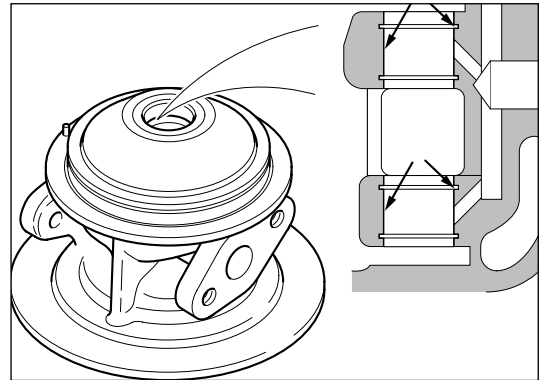

Caution Bearing housing clamp plate interface can corrode in high temperature operation. Bearing housings showing corrosion damage must be replaced.



Liquid Cooled Bearing Housing

M16 x 1.5

Ensure all coolant port threads are clean then check with the appropriate thread gauge.

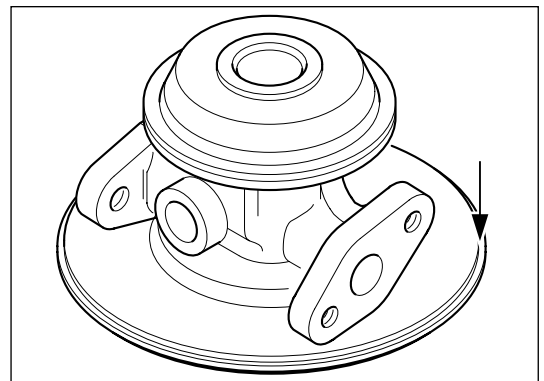

Check retaining ring (66) retaining ring groove does not exceed a maximum width dimension of: 2 mm (0.079 in).

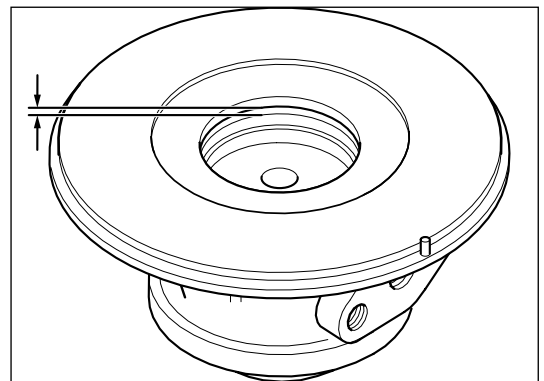

Small Components

Oil Slinger

Inspect and replace oil slinger (31) if the piston ring groove walls are scored or damaged or if groove width exceeds a maximum of 1.68 mm (0.066 in).

Check for signs of rubbing and scoring on the thrust surface and replace where damage is severe.

If the ring faces show any signs of wear replace the split ring seal, compressor (16) *.

If the free gap of the ring is less than 2.0 mm (0.08 in) replace the split ring seal, compressor (16) *.

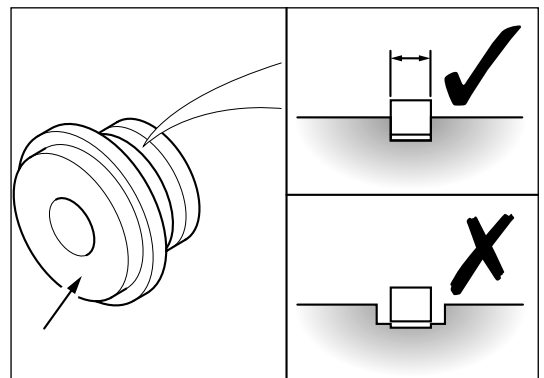



Heat Shield

Check and replace if the heat shield (38) is distorted or if signs of rubbing or cracking are visible.

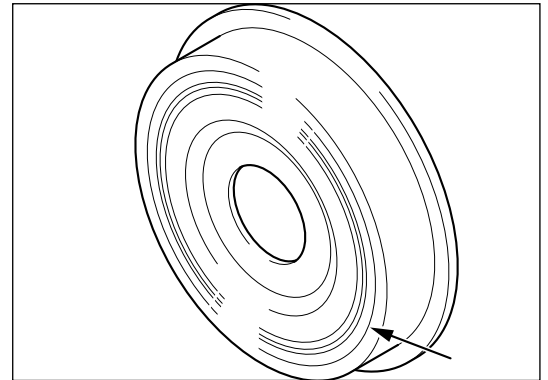

Thrust Collar

Check and replace if thrust collar (36) is scored on thrust face or if any cracks are visible.

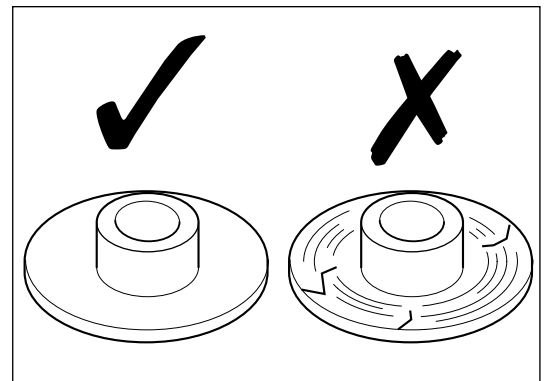

Compressor Inlet Baffle Option

Check baffle for debris entrapment damage. Always fit new type inlet baffle on reassembly.

Refer to [Turbine and Compressor Housings](#) for re-fitting instructions.

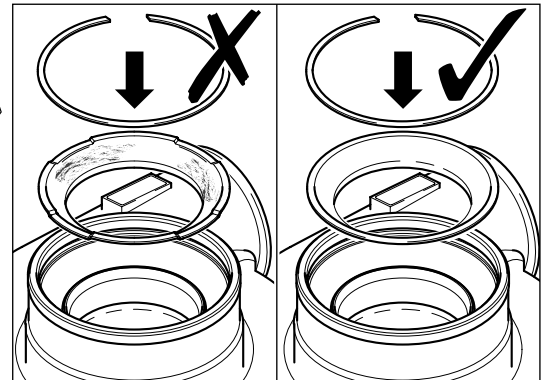

Warning  Always wear safety glasses.

Reassembly



Rotor Balance

Caution This turbocharger may have been manufactured using the 'separately piece part balanced' process. Rotor balance **MUST** always be checked on re-build.

A turbocharger should always have co-relation marks on the end of the turbine shaft and impeller nose if it has been disassembled according to the process defined in **Disassembly**. The thrust collar and oil slinger will not have co-relation marks.

Components that should be included in rotor balance are:

- Turbine wheel and shaft
- Thrust collar
- Oil slinger
- Compressor wheel
- Nut

Balance is achieved by relative rotation of components as indicated by the balance machine output.

The balance process requires a purpose built rig and compliance with the rig procedure.

Rotor balance limits appear in the **Service Data Sheet**.

On achieving balance, parts should be permanently marked for subsequent re-alignment during reassembly.

Caution Only use genuine Holset compressor wheels and assembly turbine wheels which are individually check balanced for long life and quiet operation.

Caution Always make sure the balance marks on the rotor assembly are in alignment when rebuilding the turbocharger.

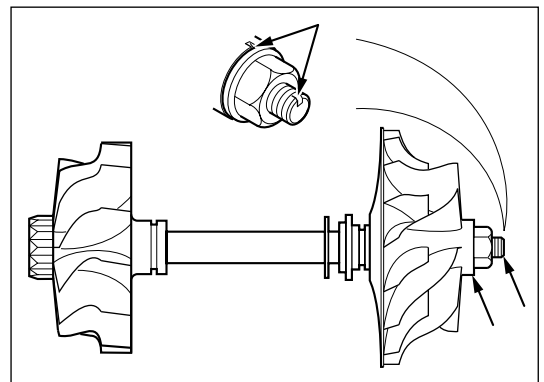
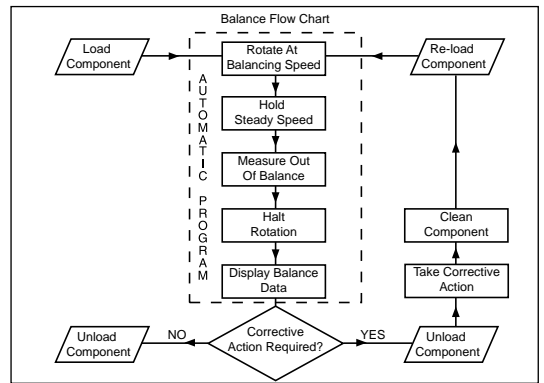
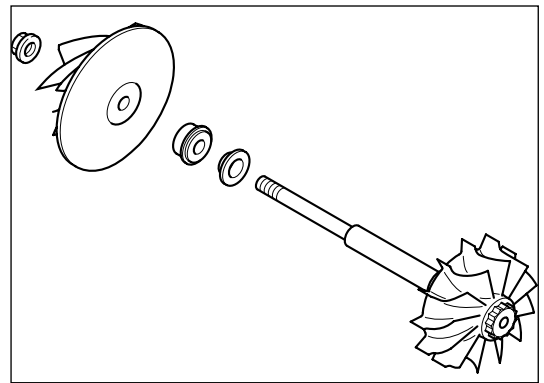
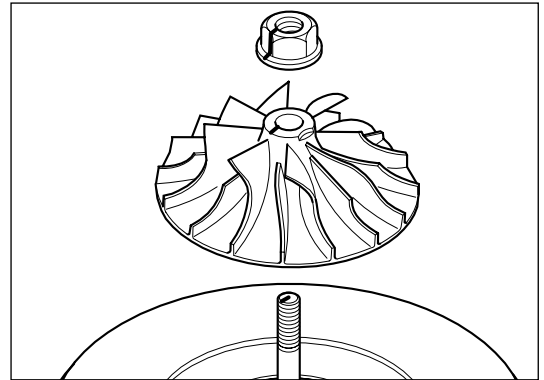



Turbocharger Reassembly

Warning  Always wear safety glasses.

Caution  Make sure the circlips are always fitted with the bevelled edge facing the journal bearing. Premature failure will result from incorrect fitting.

Place bearing housing compressor mating face on a clean surface.

Fit inner turbine end retaining ring, bearing (64) * using circlip pliers Part No. 56664.

Lubricate the journal bearing (11) * with clean engine oil and install.

Fit the outer retaining ring (64) * with the bevelled edge facing the bearing.

Turn the bearing housing over and repeat the retaining ring (64) * and journal bearing (11) * installation process at compressor end.

Install heat shield (38).

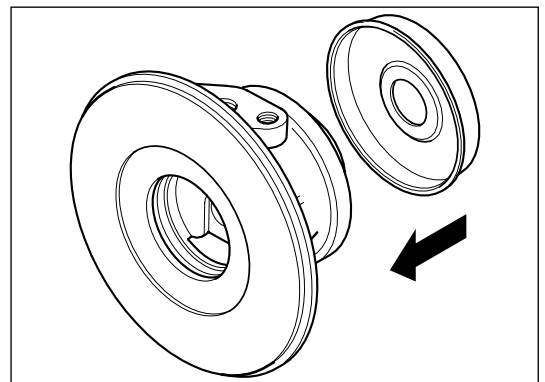
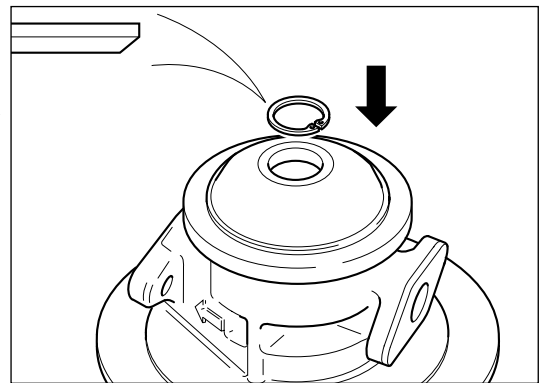
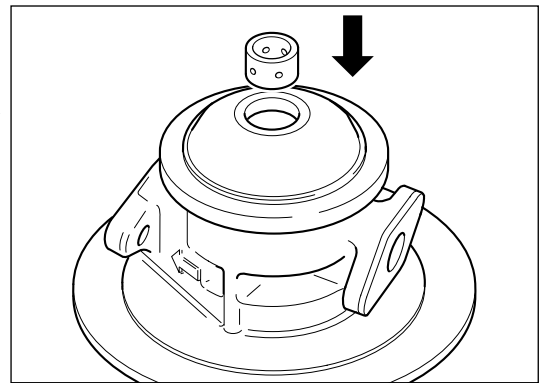
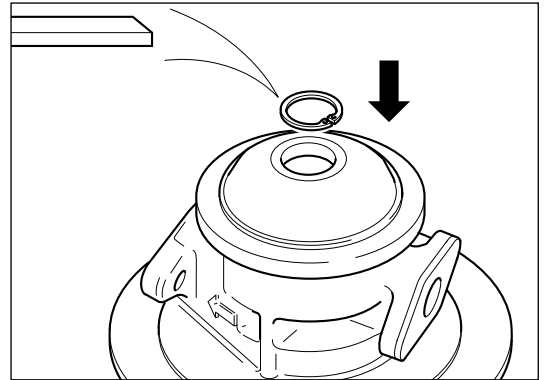



Warning  Always wear safety glasses.

Using expander pliers, install new split ring seal / seals, turbine (13) * to assembly turbine wheel (6). Some applications contain dual ring seals. It is clear from the groove width dimension whether single or dual split ring seals are required.

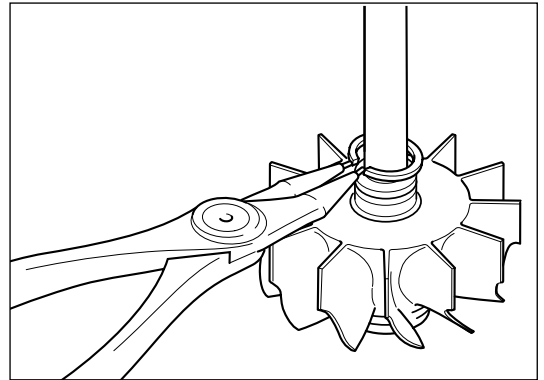

Caution  Align dual ring seals (13) so the gaps are positioned 180° apart. Gently press down on the turbine wheel - a slight rotation of the wheel will assist in properly locating the split ring seals.

Lubricate the shaft with clean engine oil and insert into the journal bearings. Positively locate the split ring seal / seals (13) * into position and ensure the assembly turbine wheel rotates freely.

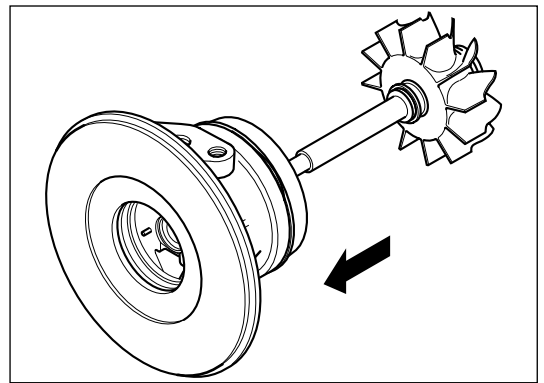
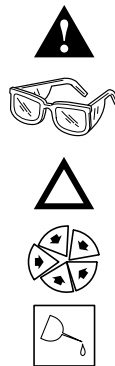

Support the assembly turbine wheel (6) in a suitable fixture.

Ensure all thrust contact faces are clean.

Insert thrust collar.

Caution  Align the balance mark on the thrust collar with that on the shaft, if applicable.

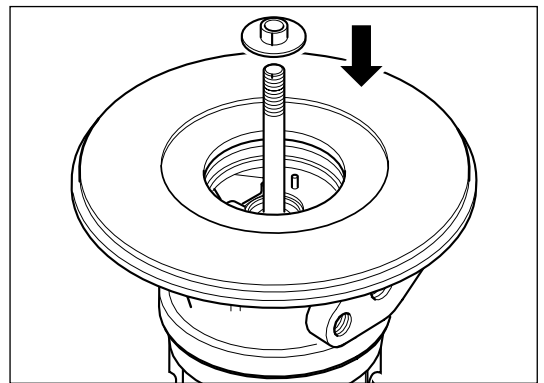

Using clean engine oil, lubricate the thrust bearing (12).
Install the thrust bearing.

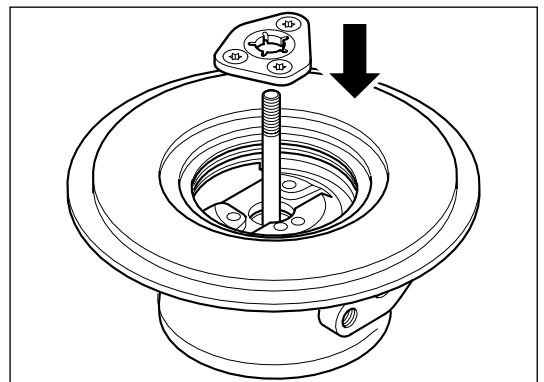



T20 TORX®

Install the 3 flat head screws (58)

Use torque wrench and T20 TORX® bit to tighten to value shown in **Service Data Sheet**.

Warning  Always wear safety glasses.

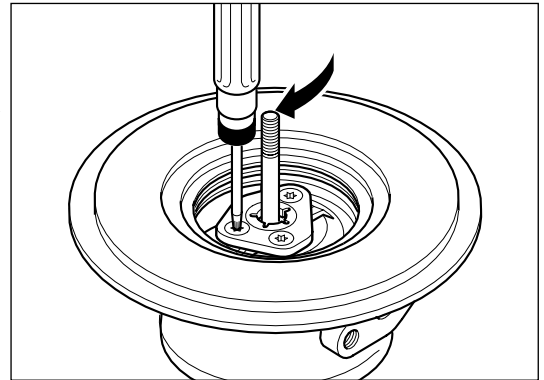
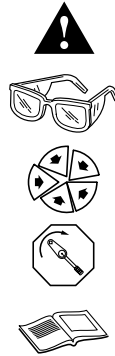

Install new split ring seal, compressor (13) * to oil slinger (31).

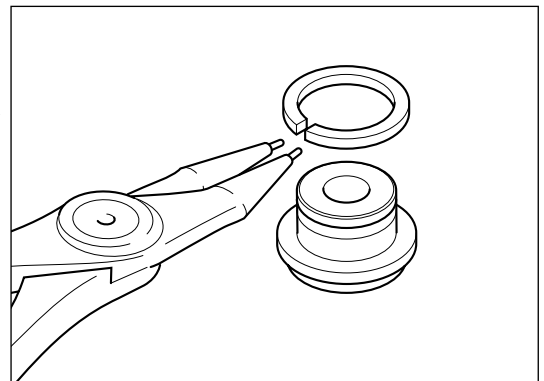

Install the oil baffle (33).

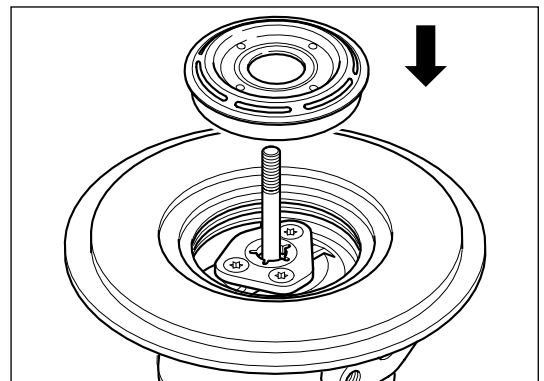

Apply a small amount of engine oil to the o-ring and insert the o-ring seal, bearing housing (32) *.

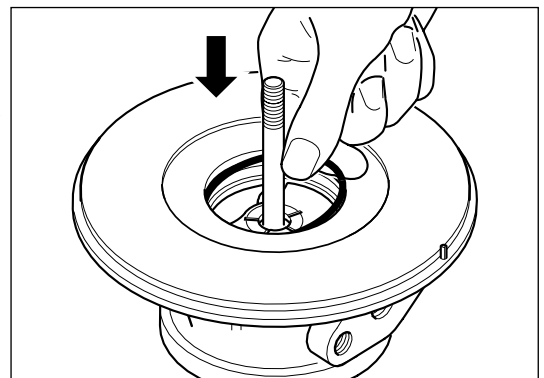



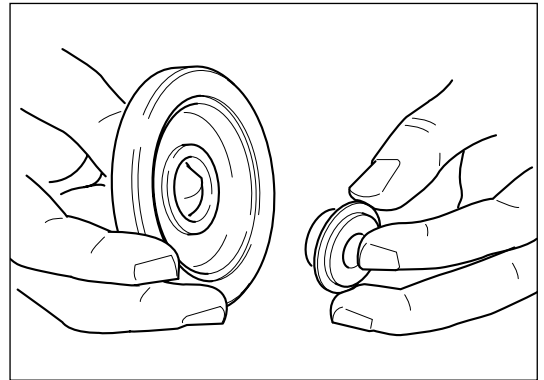

Install oil slinger (31) into oil seal plate (43).

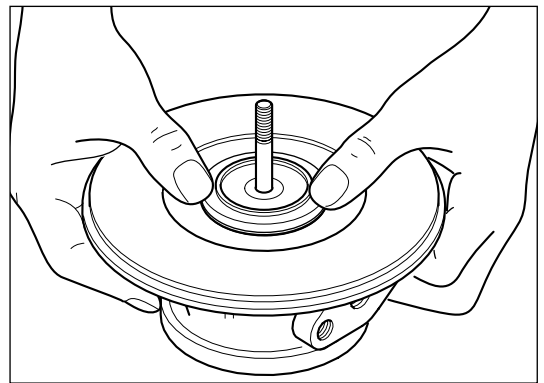

Transfer assembly from fixture locating on turbine wheel nose to one locating on bearing housing.
Install oil seal plate (43) into the bearing housing (4).





Caution  Align the balance mark on the oil slinger with that on the shaft, if applicable.

Gently tap the oil seal plate (43) with a soft hammer to seat in position.

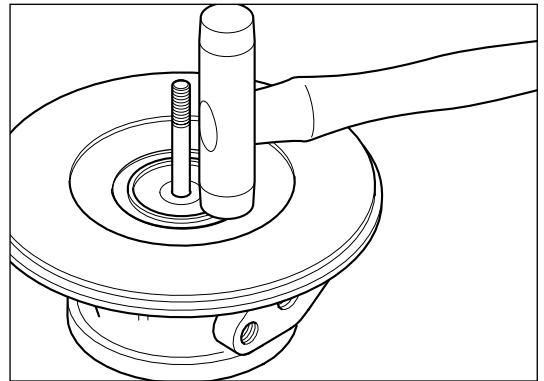
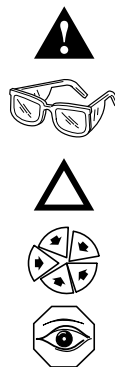
Caution  Visually inspect to ensure that o-ring has not been cut during oil seal plate insertion.





Caution  Do not rest turbocharger on turbine wheel. Always use a suitable assembly fixture.

Warning  Always wear safety glasses.

Locate part built CHRA on to 19 mm 12 point socket in suitable fixture or vice.

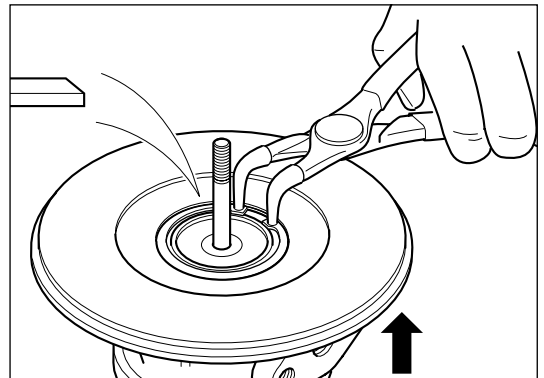
Use suitable circlip pliers to install the insert, retaining ring (66). It may be necessary to lift the bearing housing to its upper clearance limit to fully expose circlip groove.



Caution  The retaining ring must be fitted with the chamfered face upwards away from the oil seal plate.



Retaining Ring Option

Remanufactured turbochargers may be fitted with an alternative retaining ring.

To refit, hold one end of the ring in position in its groove. Press the remainder of the ring into the groove using the free hand.

Warning  Always wear safety glasses.

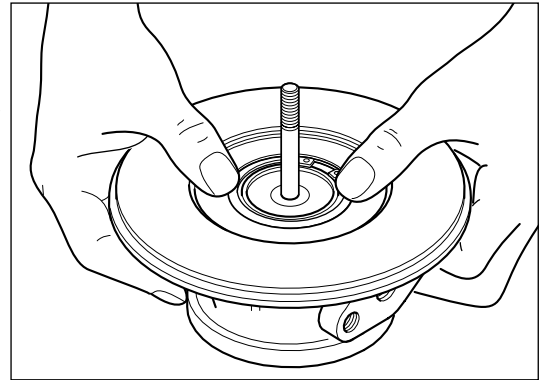

Use soft hammer and drift to ensure retaining ring (66) is properly located.

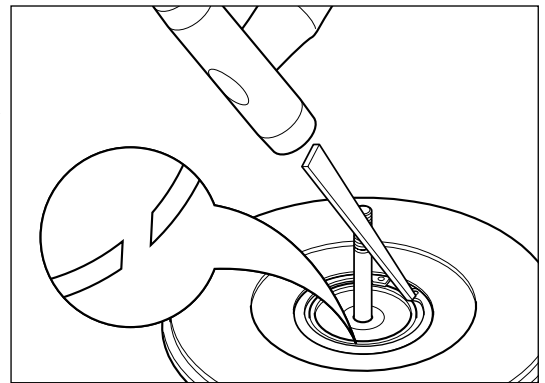

Install compressor wheel (7).

Caution  Align the balance marks scribed on shaft and compressor wheel.

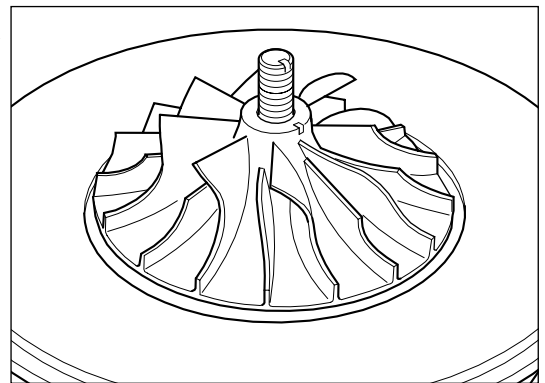

Brush the thread and nut face with an anti-seize compound to avoid loss of alignment during torque tightening.

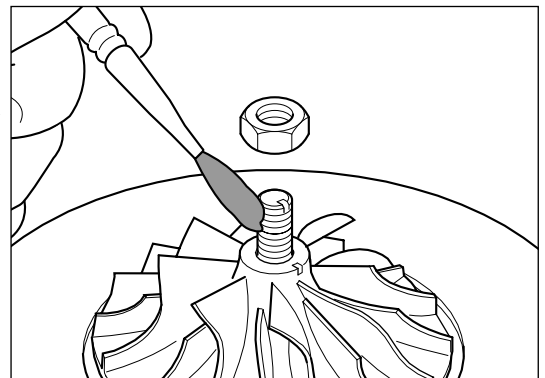



M8 LH (13 mm)

Install the locknut, compressor wheel (61) and tighten to the torque value defined in the [Service Data Sheet](#).

Caution Ensure that the balance marks remain aligned on compressor wheel and shaft throughout the torque tightening sequence.

Note
Left hand thread.

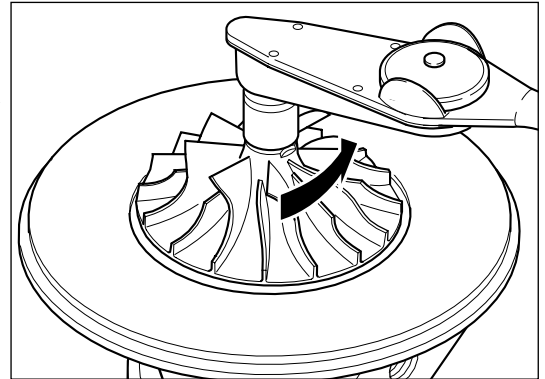

M8 x 1.25 (13 mm)

Secure turbine housing flange in vice.

Locate the C.H.R.A. into the turbine housing (5).

Install the three clamp plates (88) and tighten the six bolts (57) to the torque value shown in [Service Data Sheet](#).

Depending on housing orientation, some clamp plate bolts may have restricted access. In these cases, use a suitable torque wrench adapter attached to a specially calibrated torque wrench.

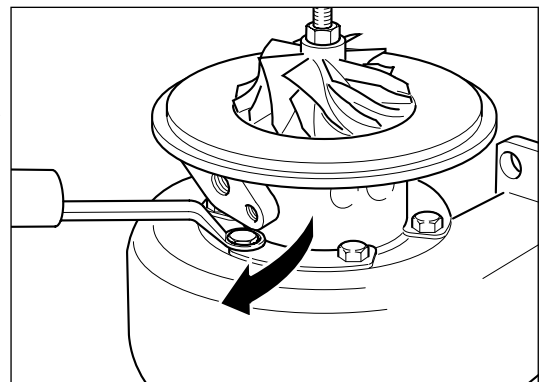

Check thrust clearance using a dial gauge. Ensure clearance is within MIN/MAX values shown in [Service Data Sheet](#).

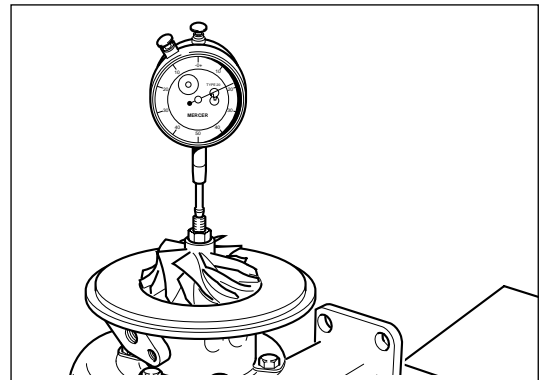

Check compressor end radial movement using a dial gauge. Ensure clearance lies within MIN/MAX TIR (Total Indicator Reading) values shown in [Service Data Sheet](#).

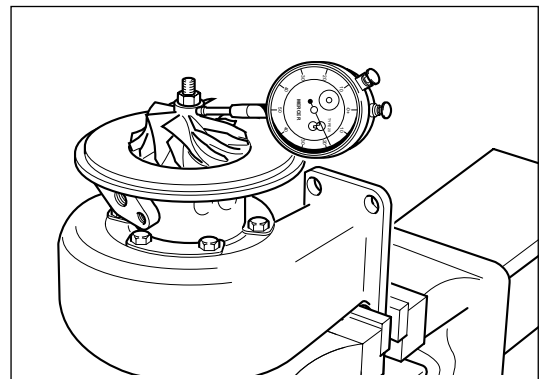



Caution 
 The compressor wheel blades can be easily damaged when the CHRA is installed.

Place the turbine and bearing housing assembly on clean surface. To refit compressor housing lubricate o-ring seal with clean engine oil and install into retaining groove. Loosely fit V-band clamp (where fitted).

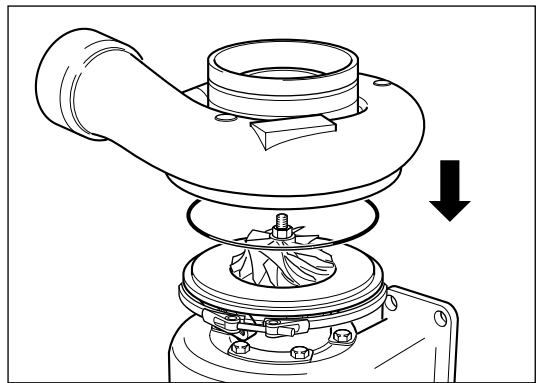

V-Band Option

1/4 UNF 28 tpi (7/16 in)

Place v-band clamp in position and torque tighten new locknut to value shown in [Service Data Sheet](#).

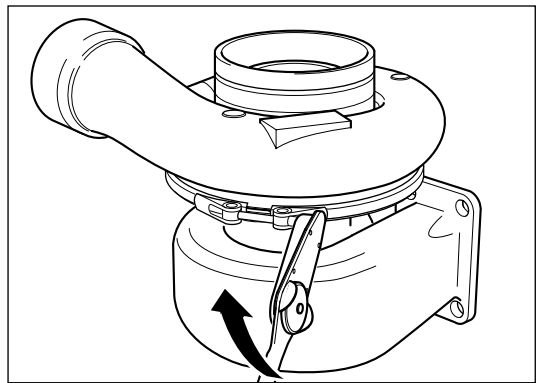
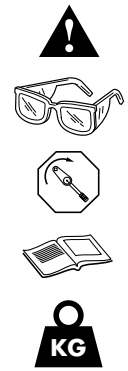

Clamp Plate/Lock Plate Option

M6 x 1.25 (10 mm)

Secure turbine housing flange in vice.

Carefully locate the compressor housing over the compressor wheel. Install the clamp plate/lock plates and torque tighten the bolts to value shown in [Service Data Sheet](#).

Warning 
 Always wear safety glasses.

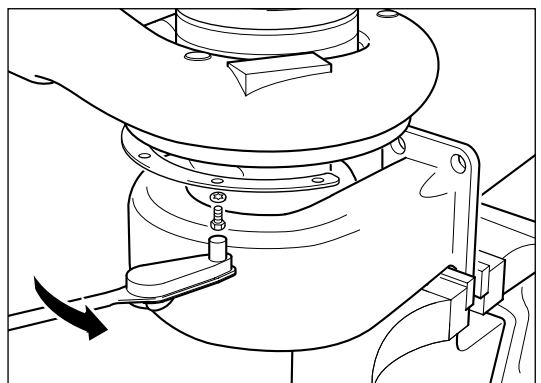

Lockplate Option

Place compressor inlet on a clean flat surface.

Use a hammer and drift to knock lockplate tabs into position against compressor housing bolts.

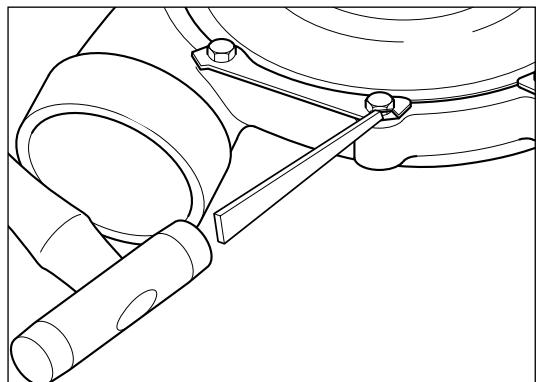



Ensure rotor assembly freely rotates.

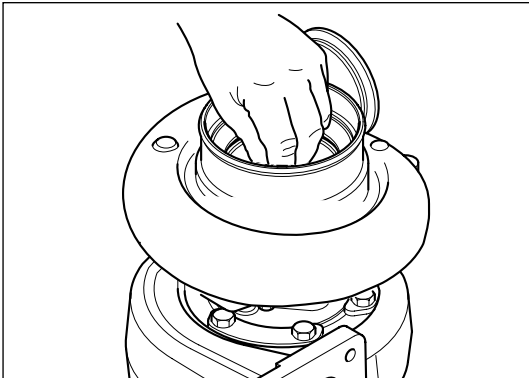



Holset H2B/C/D/E/S

Service Repair Manual

Cummins Turbo Technologies Ltd.
Aftermarket Division
Croset Avenue
Huddersfield
West Yorkshire
HD1 6SE
www.holsetaftermarket.com