

Holset HE221W

Service Repair Manual

WARNING

-  Turbochargers can be hazardous when not used as specified by the manufacturer. To prevent damage and personal injury:
- Always use the turbocharger part number specified by the engine manufacturer.
 - Use only in applications approved by the engine manufacturer.
 - Do not touch before checking surface temperatures.
 - Do not work on a running turbocharger or engine.
 - Do not modify the turbocharger in any way.
 - Disassemble and re-assemble using the engine manufacturer's instructions.
 - Use only approved spare parts.
- For advice on the safe use of turbochargers contact www.holset.com**

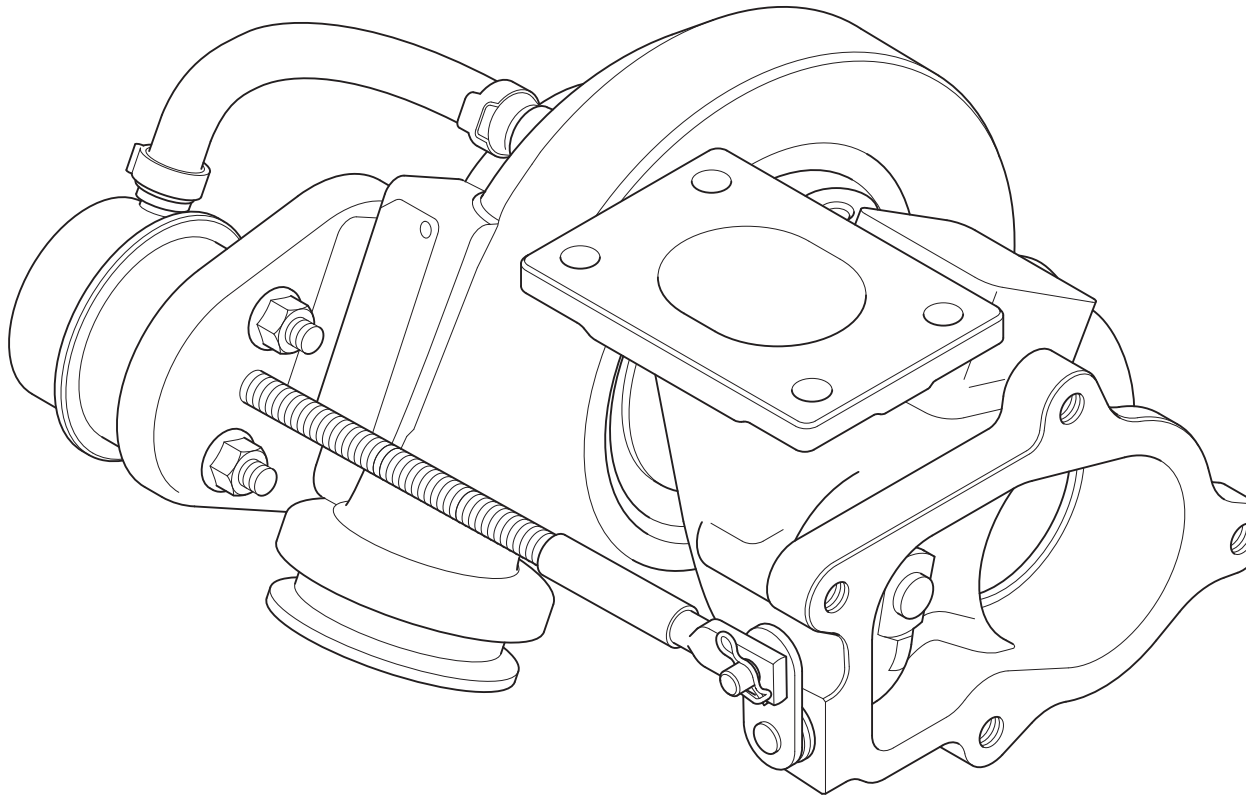

Foreword

This publication was written to assist with turbocharger installation, maintenance and overhaul. It is not a warranty of any kind expressed or implied.

The specifications and procedures in this manual are based on information in effect at the time of publication. Holset Service reserves the right to make any changes at any time without obligation. If differences are found between your turbocharger and the information in this manual, contact your local Holset approved agent.

The latest technology and the highest quality standards are used in the manufacture of Holset Turbochargers. When replacement parts are needed, we recommend using only genuine Holset parts.

Table of Contents

1: Introduction

About the Manual	1:1
How to Use the Manual.	1:1
How to Order Holset Original Parts.	1:1
Description and Operation of Turbocharger	1:2
<i>General Information</i>	<i>1:2</i>
<i>Introduction to Turbocharger Matching</i>	<i>1:2</i>
<i>Notes, Cautions and Warnings</i>	<i>1:3</i>
Installation Data.	1:4
Installation Checklist	1:5
Symbols	1:6

2: Component Identification

Turbocharger Identification	2:1
<i>Dataplate and CHRA (Core) of Turbocharger.</i>	<i>2:1</i>
<i>Installation Options</i>	<i>2:2</i>
Exploded Views	2:3
Component List.	2:4
Purchasable Service Tools.	2:6

3: Troubleshooting and Diagnosis

Fault Finding Chart	3:1
--------------------------------------	------------

4: Component Testing and Replacement

Service Tools	4:1
On Engine Checks	4:2
Bearing Clearance.	4:5
Turbine and Compressor Housings	4:6
Cleaning of Housings	4:9
Re-assembly of Housings	4:11
Wastegate Actuator Checks	4:14
Wastegate Actuator Removal	4:15
Wastegate Mechanism Check.	4:16
Wastegate Actuator Replacement	4:18

5: Turbocharger Service and Overhaul

Service Tools	5:1
Disassembly	5:2
Component Cleaning	5:6
Inspection and Testing	5:8
Reassembly	5:13

6: Service Data Sheets

HE Range Service Data Sheets	6:1
--	-----

About the Manual

The procedures in this manual were developed to instruct in the correct overhaul of the designated Holset turbocharger range for optimum performance and minimum maintenance operation.

How to Use the Manual

The manual is split into sections designed to provide service information in a logical sequence. The manual contains links to help the user navigate between relevant sections. Users who are unfamiliar with navigating in PDF documents are referred to Navigating in PDF documents in the **Adobe® Acrobat® Reader™** help file.



Contents is an interactive page with links to all the sections. It can be accessed from any page in the manual by clicking this icon.

Section 1 defines the layout of the manual, introduces the reader to the operation of the turbocharger and presents important installation guidelines.

Sections 2, 3 and 4 concentrate on Turbocharger Component Identification, Troubleshooting and Diagnosis, Component Testing and Replacement.

Section 5 identifies the Service and Overhaul procedures to be followed in the unlikely event of a major turbocharger malfunction.

Section 6 quantifies build data to ensure the turbocharger will continue to operate to Holset Service standard on completion of overhaul.

Manual sections 1 to 5 where applicable, appear as a **self extracting** compressed file which is organised according to the steps needed to most easily and correctly maintain the operation of the turbocharger. Users are required to download this file to hard disk. Section 6 has its own file identity and resides at www.holset.co.uk. so that Holset can update the Service Data as changes occur. The links between manual and service data are active only when the user is connected to the Internet.

Chapter 6 has an expiry date to encourage users to discard outdated saved or printed versions and always access the latest information available at www.holset.co.uk.



When using the manual on-line this icon will link to Holset's website to help find your nearest agent for advice and how to order Holset original parts.

How to Order Holset Original Parts

To make sure of optimum performance, certain items must be discarded during disassembly and replaced with new for re-assembly. These items are indicated in the Service and Overhaul section with the use of a * symbol.

All items showing a * are available in a basic overhaul kit.

To get the correct parts for your turbocharger, refer to the 'component identification' section of this manual to help you find the following information:

- 1) Refer to the exploded view and component list to define the major components to be replaced.
- 2) Refer to the turbocharger's dataplate which will be found on the compressor cover or wastegate actuator to define the identifying information about your turbocharger build standard.
- 3) Contact your local Holset agent with component identification nos. and dataplate assembly no., serial no. and turbocharger type.
- 4) With this information, your local agent can provide you with the optimum kit of parts for re-assembling your turbocharger for continued long life operation.

Description and Operation of Turbocharger

General Information

A turbocharger is a mechanical device which uses the engine's exhaust gases to force more air into the engine cylinders. Hot exhaust gas energy is used to turn a turbine wheel and shaft. At the other end of the shaft is the compressor impeller (or compressor wheel), which draws in air and forces it into the engine cylinders.

Supplying increased air mass flow to the engine provides improved engine performance, lower exhaust smoke density, improved operating economy and altitude compensation. The turbocharger has proven to be one of the most beneficial devices for improving engine performance. It performs its job very well, as long as it is properly cared for.

Introduction to Wastegate Turbochargers

The need for wastegated turbochargers

A standard turbocharger can be perfectly matched to only one particular engine condition, eg maximum torque speed or maximum load speed. At this engine speed, the turbocharger supplies the optimum mass of air to give the required air/fuel ratio. At other speeds the air/fuel ratio cannot be held at the optimum hence fuel consumption and emission levels worsen.

Engine emission legislations have forced manufacturers to improve their engine efficiencies, particularly at low speeds where low air/fuel ratios cause high smoke levels.

The Holset integral wastegate turbocharger is a cost effective solution to this problem and for a small increase in complexity, a simple variable flow turbine housing has been achieved.

Integral wastegate turbochargers have been available for passenger cars for many years. Holset has developed such a turbocharger with components designed for extended life equal to that of standard commercial vehicle turbochargers.

The importance of correctly servicing the turbocharger

A turbocharger requires accurate assembly at point of manufacture. It is very important to adhere to setting limits when servicing the turbocharger, as failure to do so could result in turbocharger or engine failure.

Effects of wrong match

Possible consequences if turbocharger boost pressure is too low:-

- Engine runs fuel rich
- Exhaust temperature increase
- Hydrocarbon levels increase
- High cylinder temperature risks damage to engine pistons
- Fuel consumption increase
- Smoke levels increase
- Risks of failing emissions tests

Possible consequences if turbocharger boost pressure is too high:-

- Engine runs fuel weak (lean)
- Excessive boost overspeeds turbocharger
- Increased cylinder pressure risks damage to engine head gasket, pistons and valves
- Nitrous oxide levels increase
- Turbocharger bearing failure and wheel fatigue problems
- Intercooler load increases causing engine to overheat, risking piston damage

Notes, Cautions and Warnings

Notes, Cautions and Warnings are used in this manual to emphasise important or critical instructions.

Note

Information which is essential to highlight.

Caution

Maintenance or Service procedures which if not strictly followed, will result in damage or destruction of the turbocharger.

Warning

Maintenance or Service procedures which if not correctly followed will result in personal injury or loss of life.

Note

Holset turbochargers can be remanufactured using recovered parts. Where it is necessary to dispose of components or whole turbochargers, an environmentally responsible process such as recycling should be used, with due regard to local laws.

Note

Holset Service receives many turbocharger returns that are no fault found. Before assuming the turbocharger is not performing to specification always refer to the engine diagnostic system and the troubleshooting diagnostic procedures of this manual.

Warning

Turbocharger surface temperature during operation can achieve 700°C (1300°F). The designated turbocharger range weighs up to 4.8 kg (10.6 lb) and is fitted with external parts that are sensitive to manual handling.

Caution

This turbocharger requires a new standard of balancing process on rebuild using a proprietary vibration sorting rig (VSR).

The turbocharger will not have any co-relation marks. If you intend to overhaul/repair the turbocharger, and do not have access to a VSR machine, we recommend that you send the reassembled core in appropriate packaging to protect the turbine and compressor blades to an approved Holset agent with VSR facilities.

As the results of vibration based tests are rig specific, the balance limits shown in Holset's Service Data Sheets are advisory only. Refer to repair agent to warrant durability, noise and vibration level of the specific VSR balancing process used.

If you are in any doubt regarding the balancing process, please contact the local Holset agent for assistance.

Warning

Some parts are manufactured in Viton that requires special treatment in the case of repair and service after fire.

Installation Data

1. Holset Service receives many turbocharger returns that are no fault found. Before assuming the turbocharger is not performing to specification always refer to the engine diagnostic system and the fault finding chart of this manual to make all the recommended health checks.
2. It is important that intake and exhaust systems are fitted in accordance with the recommendations of the Equipment and Engine manufacturers. Limiting mass inertia loading is critical to turbocharger whole life operation. Maximum engine vibration input must not exceed 8.9g.
3. The air filter must remove particles greater than 5 μm at an efficiency of 95% and be of sufficient capacity to match the air consumption of the engine. Recommended filters should always be used with a pressure drop indicator. Intake systems must be capable of withstanding depressions up to 6.9 kPa (1.0 lbf/in²).
4. Hose and clip connections of intake manifold systems must be capable of withstanding the turbocharger pressure ratio. V band clamps are preferred and must be used above 3:1 pressure ratio.
5. Exhaust systems must be capable of operating at exhaust back pressures of up to 10 kPa (1.5 lbf/in²). This limit is increased to 13.4 kPa (2.0 lbf/in²) if a catalytic converter is fitted. Exhaust brake applications are permitted to impose 450 kPa (65.3 lbf/in²) back pressure.
6. Oil should be filtered to 10 μm with efficiency of 60% TWA (Time Weighted Average) /20 μm with efficiency of 85% TWA. Efficiency assessed using ISO Standard 4572/SAE J 1858.
7. The oil quality must be as specified by the engine manufacturer and will be a minimum API SE - CD (MIL - L- 2104C) specification. Recommended oil change intervals are 5000 to 10,000 km (250 to 500 h) depending on duty. Improved life can be obtained by using super high performance diesel (SHPD) oils, particularly in industrial applications which use extended oil drain periods.
8. Normal oil temperature is 95+/-5°C (203+/-9°F). It should not exceed 120°C (248°F) under any operating condition.
9. Any pre-lube oil must be clean and meet the minimum CD classification.
10. The attitude of turbine housing, bearing housing and compressor cover is fixed. During installation, do not attempt to rotate these components. Inclined turbocharger installation is not recommended. If an installed angle is necessary, oil inlet centreline must be +/- 10 degrees from vertical and rotor centreline +/- 5 degrees from horizontal.
11. Holset permits oil return pipes to decline at an overall angle of not less than 30 degrees below horizontal. All turbocharger applications require a pipe of internal diameter greater than 14 mm which has integrated connectors. To ensure oil returns into the engine under all operating conditions, the return connection into the engine sump must not be submerged and the outlet flange of the turbocharger must be 50mm above the maximum oil level of the engine sump pan. Crankcase pressure should be limited ideally to 0.8 kPa (0.12 lbf/in²) but 1.4 kPa (0.20 lbf/in²) can be accepted by reference to Holset.
12. Oil pressure of 150 kPa (20 lbf/in²) must show at the oil inlet within 3 - 4 seconds of engine firing to prevent damage to turbocharger bearing system. A flexible supply pipe is recommended. Turbocharger speed must not exceed 90,000 rev/min until 150 kPa (20 lbf/in²) is achieved.
13. The minimum oil pressure when the engine is on load must be 210 kPa (30 lbf/in²). Recommended full load rated speed operating pressure is 350 kPa (50 lbf/in²) although 500 kPa (72 lbf/in²) is permitted during cold start up. Under idling conditions pressure should not fall below 80 kPa (11.5 lbf/in²).
14. Recommended oil flows for the turbochargers are 0.4 litre/min at idle and 1.4 litre/min at maximum engine speed.
15. Do not use liquid gasket substances or thread sealant as any excess can enter the turbocharger oil to obstruct flow.

Note:

100 kPa = 1 bar (14.5037 lbf/in² = psi).

Installation Checklist

1. Always understand why the original turbocharger needs replacing before fitting another unit.
2. Check the turbocharger dataplate to ensure the Part No. is correct for the engine/application.
3. Check the engine exhaust, intake and aftercooler systems are clean and without obstruction i.e. free from oil, gasket pieces, dust/dirt/carbon or foreign objects.
4. Replace the oil and air filters using replacement parts specified by the equipment manufacturer.
5. Change the engine oil using the type specified by the engine manufacturer.
6. Check that the turbocharger oil inlet and drain pipes and connectors are clean, free from obstruction and will not leak under pressure.
7. Check that the coolant pipes of water cooled bearing housing applications and connectors are clean, free from obstruction and will not leak under pressure.
8. To pre-lube the turbocharger bearings, pour some clean engine oil into the oil inlet and rotate the turbocharger rotor assembly by hand.
9. Check that the exhaust manifold flange is flat and undamaged. Mount the turbocharger on the flange and check that the turbine inlet gasket fits properly without obstructing the gas passages.
10. Assemble the air intake and boost outlet connections. Check that the connections are well made and will not leak in use.
11. Check the exhaust system is fitted using the original mounting arrangement provided by the equipment manufacturer. Always re-fit any supports/brackets back in position to ensure the system is correctly supported.
12. Assemble the exhaust system to the turbine housing outlet. Check that the gasket/connection is well made and will not leak in use.
13. Assemble any coolant pipes and check that the connections are well made, without obstruction and will not leak in use.
14. Assemble the turbocharger oil inlet pipe and check that the connection is clean, well made and will not leak in use.
15. Check all clamps and fasteners are correctly tightened to the torque recommended by the equipment manufacturer.
16. Make any ECU checks recommended by the engine manufacturer.
17. Crank the engine WITHOUT firing until engine oil flows out of the turbocharger drain flange.
18. Assemble the oil drain pipe and check that the connection is well made, without obstruction and will not leak in use.
19. Start the engine and run at idle speed for approximately 1 minute so that the oil supply system is fully operational.
20. Accelerate the engine and check that there are no leaks/obstructions of air/oil/coolant/gas under pressure.
21. Check that no hose or connection deforms under normal operation.
22. Before switching off the engine, leave it running at idle speed for at least 1 minute to cool the turbine.

Symbols

Symbole - Deutsch

In diesem Handbuch werden die folgenden Symbole verwendet, die wesentliche Funktionen hervorheben. Die Symbole haben folgende Bedeutung:



WARNUNG - Unterhaltungs und Wartungsverfahren müssen genau befolgt werden, da ein Nichtbeachten zu Personenschäden oder tödlichen Verletzungen führt.



ACHTUNG - Falls Unterhaltungs und Wartungsverfahren nicht genau beachtet werden, kann der Turbolader dadurch beschädigt oder zerstört werden.



AUSBAU bzw. **ZERLEGEN**.



EINBAU bzw. **ZUSAMMENBAU**.



INSPEKTION erforderlich.



Teil oder Baugruppe **REINIGEN**.



DIMENSION - oder **ZEITMESSUNG**.



Teil oder Baugruppe **ÖLEN**.



WERKZEUGGRÖSSE wird angegeben.



ANZUG auf vorgeschriebenes Drehmoment erforderlich.



Sicherstellen, daß die **AUSWUCHTMARKEN** an der Rotor-Baugruppe richtig ausgerichtet sind.



Elektrische **MESSUNG DURCHFÜHREN**.



Weitere Informationen an anderer Stelle bzw. in anderen Handbüchern.



Schutzkleidung muß immer getragen werden.



Deutet an, daß Teile schwer sein können.



Website-Verzeichnis mit Ihrem nächsten Holset-Händler.



Gehe zu Inhalt

Symbols - English

The following group of symbols have been used in this manual to help communicate the intent of the instructions. When one of the symbols appears, it conveys the meaning defined below.



WARNING - Serious personal injury or extensive property damage can result if the warning instructions are not followed.



CAUTION - Minor personal injury can result or a part, an assembly or the engine can be damaged if the caution instructions are not followed.



Indicates a **REMOVAL** or **DISASSEMBLY** step.



Indicates an **INSTALLATION** or **ASSEMBLY** step.



INSPECTION is required.



CLEAN the part or assembly.



PERFORM a mechanical or time **MEASUREMENT**.



LUBRICATE the part or assembly.



Indicates that a **WRENCH** or **TOOL SIZE** will be given.



TIGHTEN to a specific torque.



Ensure that the **BALANCE MARKS** on the rotor assembly are in alignment



PERFORM an electrical **MEASUREMENT**.



Refer to another location in this manual or another publication for additional information.



Please wear protective clothing at all times.



Indicates components may be heavy.



Website access to find your nearest Holset Agent.



Go to contents

Simbolos - Español

Los simbolos siguientes son usados en este manual para clarificar el proceso de las instrucciones. Cuando aparece uno de estos simbolos, su significado se especifica en la parte inferior.



ADVERTENCIA – Procedimientos de Mantenimiento o Servicio que al no seguirse resultarán en daños personales o pérdida de vida.



ATENCION – Procedimientos de Mantenimiento o Servicio que al no seguirse al pie de la letra, resultarán en el daño o la destrucción del turbosobrealimentador.



Indica un paso de **REMOCION** o **DESMONTAJE**.



Indica un paso de **INSTALACION** o **MONTAJE**.



Se requiere **INSPECCION**.



LIMPIESE la pieza o el montaje.



Ejecutese una **MEDICION** mec-nica o del tiempo.



LUBRIQUESE la pieza o el montaje.



Indica que se dar- una **LLAVE DE TUERCAS** o el **TAMAÑO DE HERRAMIENTA**.



APRIETESE hasta un par torsor especifico.



Ceriórese de que est-n alineadas las marcas de balance en el rotor.



EJECUTESE una **MEDICION** eléctrica.



Para información adicional refiérase a otro emplazamiento de este manual o a otra publicación anterior.



Favor de siempre llevar ropa protectora.



Indica que los componentes pueden ser pesados.



Acceso a Sitio Web para localizar su agente Holset más cercano.



Ir a la tabla de materias

Symboles - Français

Les symboles suivants sont utilisés dans ce manuel pour aider à communiquer le but des instructions. Quand l'un de ces symboles apparaît, il évoque le sens défini ci-dessous:



ATTENTION DANGER - Procédures de maintenance ou d'entretien qui, si elles ne pas observées correctement, auront pour résultat des lésions corporelles ou un décès.



MISE EN GARDE - Procédures de maintenance ou d'entretien qui, si elles ne sont pas observées strictement, auront pour résultat de causer des dégâts au turbocompresseur ou de conduire à sa destruction.



Indique une opération de **DEPOSE**.



Indique une opération de **MONTAGE**.



L'INSPECTION est nécessaire.



NETTOYER la pièce ou l'ensemble.



EFFECTUER une **MESURE** mécanique ou de temps.



GRAISSER la pièce ou l'ensemble.



Indique qu'une **DIMENSION DE CLE** ou **D'OUTIL** sera donnée.



SERRER à un couple spécifique.



S'assurer que les repères d'équilibrage sur l'ensemble de rotor sont alignés.



EFFECTUER une **MEASURE** électrique.



Se reporter à un autre endroit dans ce manuel ou à une autre publication pour obtenir des information plus complètes.



Il faut toujours mettre vêtements de protection.



Indique que les composants peuvent être lourds.



Accès au site Web pour trouver l'agent Holset le plus proche.



Aller au sommaire

Símbolos - Português

Os símbolos a seguir serão utilizados neste manual para facilitar a comunicação das instruções e seus significados estão descritos abaixo.



ATENÇÃO - Os procedimentos de Manutenção ou Serviços que não forem seguidos correctamente resultarão em ferimentos pessoais ou riscos de vida.



AVISO - Os procedimentos de Manutenção ou Serviço que não forem rigorosamente seguidos resultarão em danos ou destruição do carregador turbo.



Indica um passo de **DESMONTAGEM**.



Indica um passo de **MONTAGEM**.



Requer inspeção.



LIMPE a peça ou conjunto.



Requer Medição mecânica ou de tempo.



LUBRIFIQUE a peça ou o conjunto.



Indica necessidade de **APERTO**.



TORQUEAR de acordo com o especificado.



Assegure-se de que as **MARCAS DE BALANCEAMENTO** do conjunto eixo rotor estejam alinhadas.



Requer medição **ELÉTRICA**.



Procure em outra seção deste manual ou em publicação para obter informações adicionais



Por favor, sempre utilize EPI (Equipamento de Proteção Individual)



Indica que os componentes podem estar pesados.



Visite o Website para encontrar o seu Agente Holset mais perto.



Vá para Conteúdo

Turbocharger Identification



Dataplate

Note

Dataplates will be fitted to the compressor housing (8). The information from the dataplate must be quoted for service and parts support.

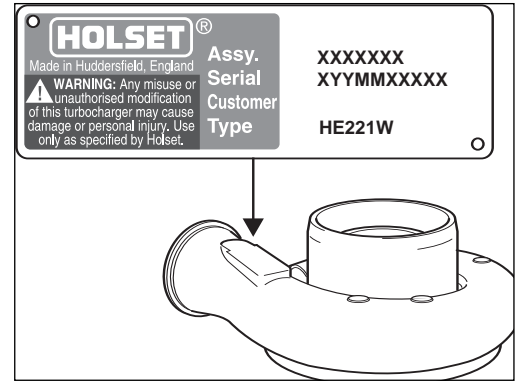

Center Housing Rotating Assembly (CHRA) (2)

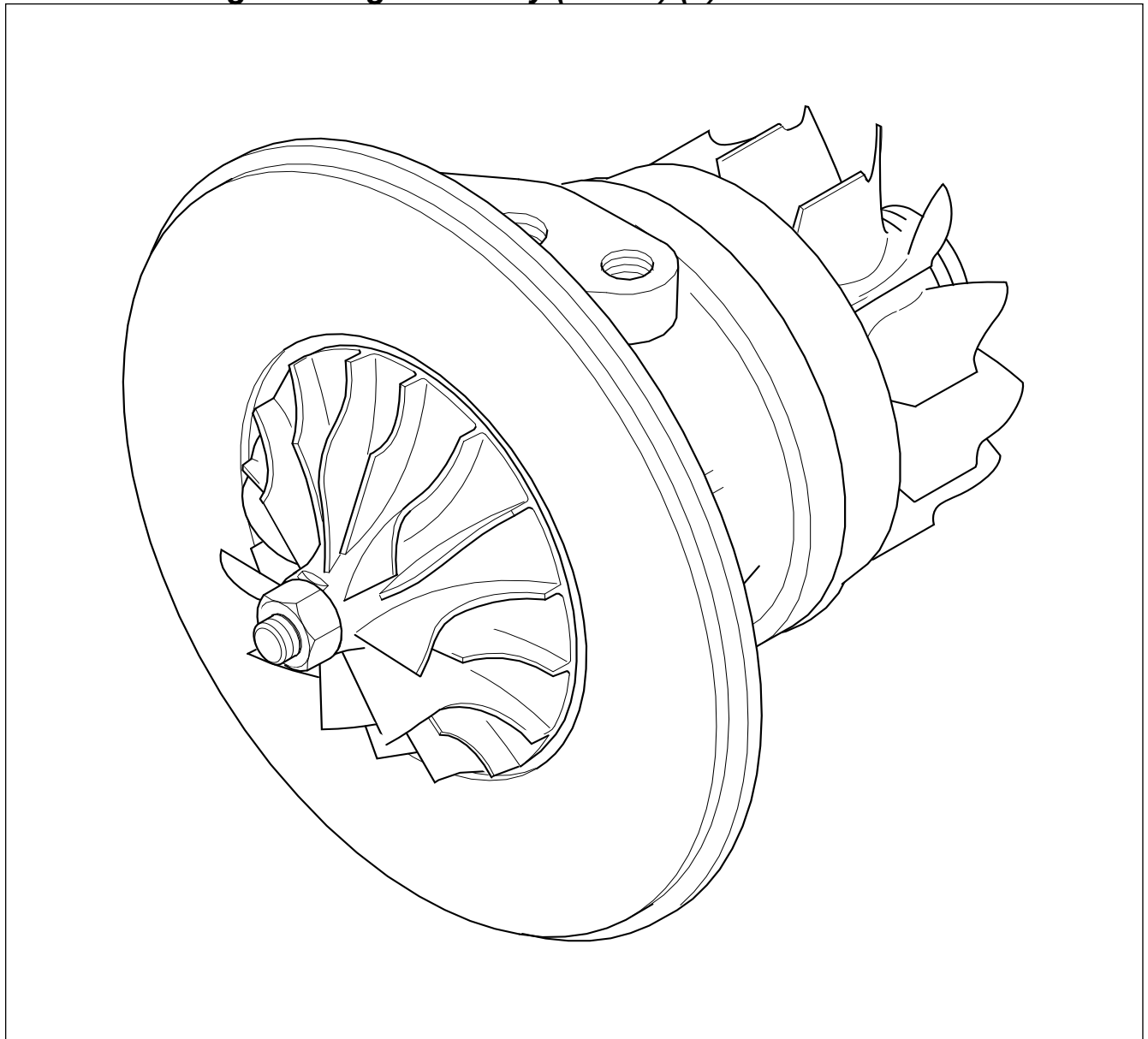



Installation Options

Type A

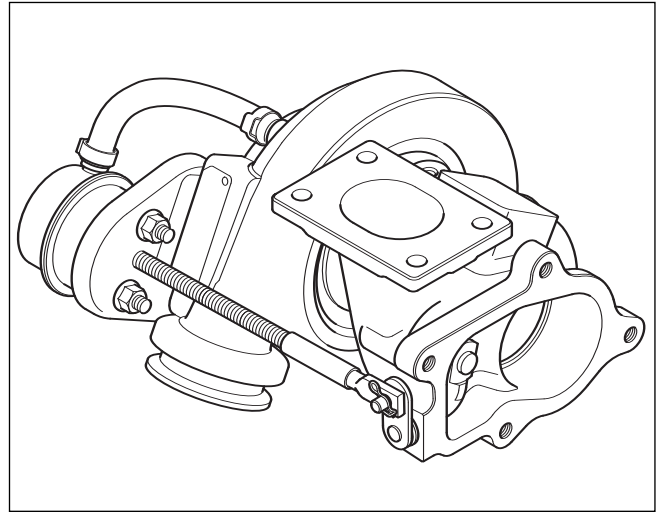

Type B

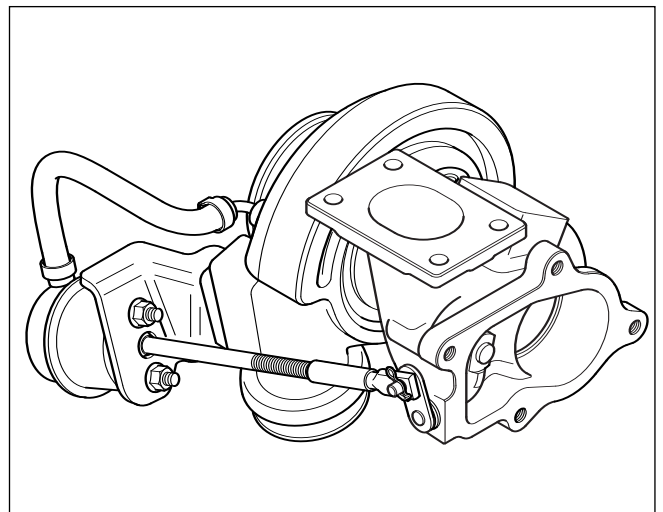

Type C

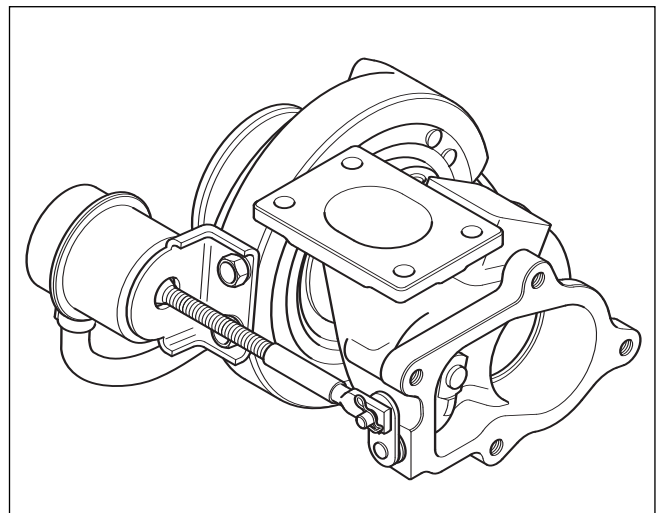

Exploded View

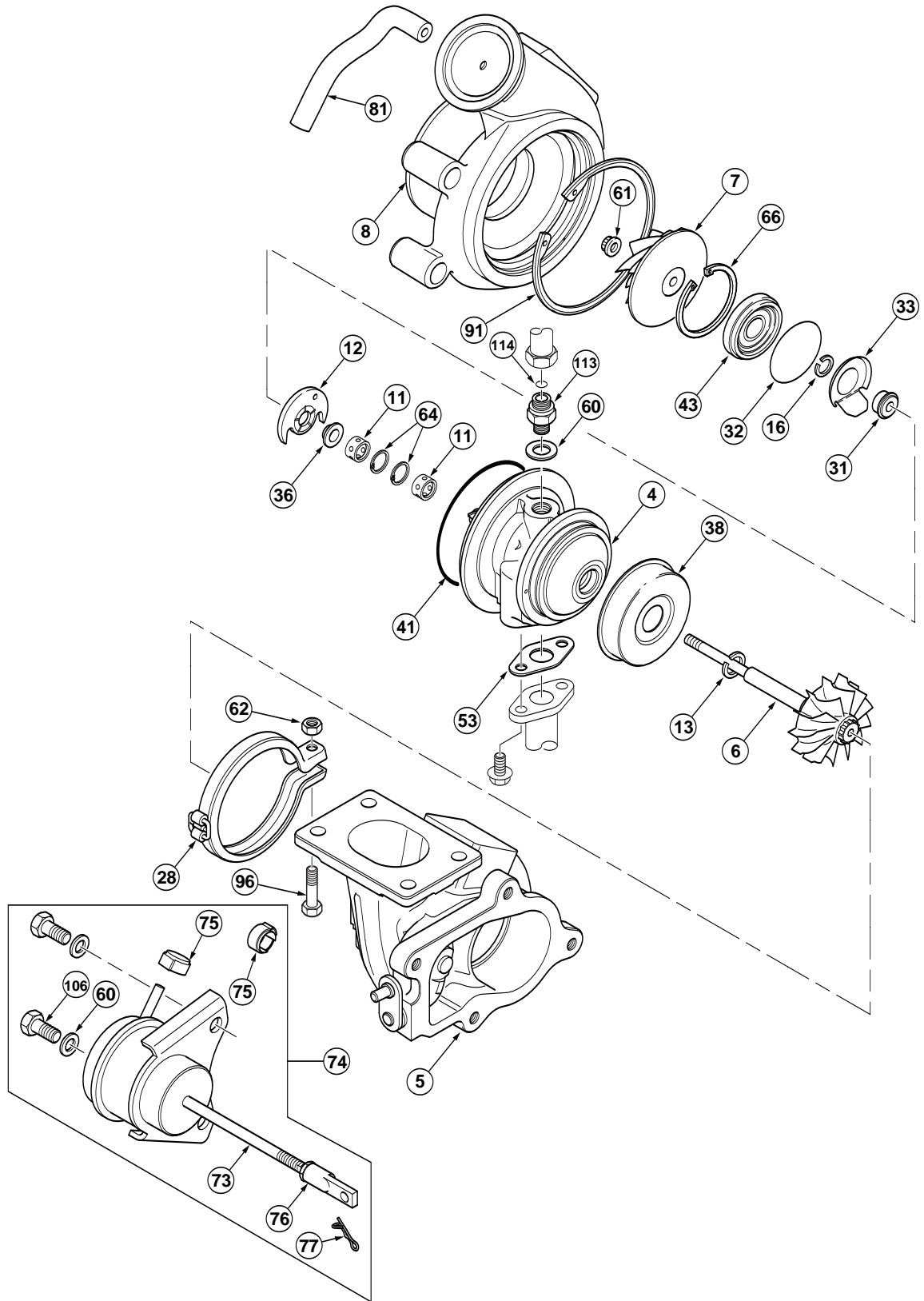

Note

Exploded views represent a generic build standard. Parts may be added or subtracted in specific applications.

Component List



Item No.	Description	Quantity
All Applications		
1	Repair Kit CHRA (Core)*	1
2	CHRA (Core)	1
4	Bearing Housing	1
5	Turbine Housing	1
6	Assembly, Turbine Wheel	1
7	Compressor Wheel	1
8	Compressor Housing	1
11	Journal Bearing*	2
12	Thrust Bearing*	1
13	Split Ring Seal, Turbine*	1
16	Split Ring Seal, Compressor*	1
28	V-Band Clamp, Turbine	1
31	Oil Slinger	1
32	O-Ring Seal, Bearing Housing*	1
33	Oil Baffle	1
36	Thrust Collar	1
38	Heat Shield	1
41	O-Ring Seal, Compressor Housing*	1
43	Oil Seal Plate	1
53	Gasket, Oil Outlet	1
60	Plain Washer	1
61	Locknut, Compressor Wheel	1
62	Locknut, V-Band	1
64	Retaining Ring, Bearing*	2
66	Retaining Ring, Insert	1
91	Retaining Ring, Compressor Housing	1
96	Screw, V-band	1
113	Adaptor, Oil Inlet	1
114	O-Ring Seal, Oil Inlet	1

Component List



Item No.	Description	Quantity
Wastegate Applications		
74	Wastegate Kit comprising:	1
73	Actuator	1
75	Hose Clip	2
76	End Link, Assembly	1
77	Retaining Ring, End Link	1
106	Screw, Actuator	2
60	Plain Washer	2
128	Jam Nut	0/1
143	Breakoff Nut	0/1
81	Hose	1

Purchasable Service Tools



Service Tools

The following special tools can be purchased from your local Authorised Repair Location. The use of these tools is recommended and where necessary they are shown in the appropriate service procedure.

Part No.	Tool Description	Tool Illustration
3575186	Circlip Pliers	
4027202	Wastegate Air Feed Adapter	
4027203	Wastegate Air Feed Adapter	
4027204	E-Clip Tool	

Caution

All Service and Maintenance settings are shown in Holset's Service Data Sheet. It is essential that these settings are used. Common tools found in mechanic's tool box not included.

Fault Finding chart - All Applications



	Engine Running Hot	Poor Transient Response	Smoke	Engine Lacks Power	Black Exhaust Smoke	Blue Exhaust Smoke	High Oil Consumption	Turbocharger Noisy	Cyclic Sound from the Turbocharger	Oil Leak from Compressor Seal	Oil Leak from Turbine Seal
Dirty air cleaner Clean or replace element according to manufacturer's recommendations	●	●	●	●	●	●	●			●	
Restricted compressor intake duct Remove restriction or replace damaged parts as required	●	●	●		●	●	●	●	●	●	
Restricted air duct from compressor to intake manifold Remove restriction or replace damaged parts as required	●	●		●	●			●			
Restricted intake manifold Refer to engine manufacturer's manual and remove restriction	●	●		●	●			●			
Air leak in feed from air cleaner to compressor Replace seals, gaskets or tighten fasteners as required								●			
Air leak in feed from compressor to intake manifold Replace seals, gaskets or tighten fasteners as required	●	●	●	●	●	●	●	●			
Air leak between intake manifold and engine Refer to engine manufacturer's manual and replace gaskets or tighten fasteners as required	●		●	●	●	●	●	●			
Foreign object in exhaust manifold (from engine) Refer to engine manufacturer's manual and remove obstruction				●	●	●	●	●		●	
Restricted exhaust system Remove restriction or replace damaged parts as required	●			●	●					●	
Exhaust manifold cracked, gaskets blown or missing Refer to engine manufacturer's manual and replace gaskets or damaged parts as required		●	●	●	●			●			
Gas leak at turbine inlet/exhaust manifold joint Replace gasket or tighten fasteners as required		●	●	●	●			●			
Gas leak in ducting after turbine outlet Refer to engine manufacturer's manual and repair leak		●						●			
Restricted turbocharger oil drain line Remove restriction or replace damaged parts as required						●	●			●	●
Restricted engine crankcase breather Refer to engine manufacturer's manual, clear restriction						●	●			●	●
Turbocharger bearing housing sludged or coked Change engine oil and oil filter, overhaul or replace turbocharger as required						●	●			●	●
Fuel injection pump or fuel injectors incorrectly set Refer to engine manufacturer's manual and replace or adjust faulty components as required		●	●	●	●						
Engine valve timing incorrect Refer to engine manufacturer's manual for correct settings and adjust as required				●	●						
Worn engine piston rings or liners Refer to engine manufacturer's manual and repair as required				●	●	●	●			●	●
Burnt valves and/or pistons Refer to engine manufacturer's manual and repair as required				●	●	●	●			●	●
Excessive dirt build up on compressor wheel and/or diffuser vanes Contact your local approved dealer				●	●	●	●	●	●	●	●
Turbocharger damaged Find and correct cause of failure, or replace turbocharger as necessary				●	●	●	●	●		●	●

Fault Finding chart - Wastegate Applications



	Engine Running Hot	Poor Transient Response	Smoke	Engine Lacks Power	Black Exhaust Smoke	Blue Exhaust Smoke	High Oil Consumption	Turbocharger Noisy	Cyclic Sound from the Turbocharger	Oil Leak from Compressor Seal	Oil Leak from Turbine Seal
Failed actuator diaphragm Replace using correct Actuator Service Kit	●							●			
Seized wastegate valve (in turbine housing) Free valve in accordance with details in the appropriate Holset publication replace complete turbine housing sub-assembly	●	●									
Leaking actuator hose Replace hose and clips	●							●			
Wastegate mechanism set incorrectly Contact your approved Holset agent for correct setting procedure	●	●	●	●				●			

Service Tools



The following special tools are recommended to perform procedures in this manual. The use of these tools is shown in the appropriate procedure.

Part No.	Tool Description	Tool Illustration
	Torque Wrench	
	Dial Gauge and Dial Gauge Adaptor	
	Pressure Gauge Regulated Air Supply Max 300 kPa (45 lbf/in ²)	

Caution

All Service and Maintenance settings are shown in Holset's Service Data Sheet. It is essential that these settings are used. Common tools found in mechanic's tool box not included.

On Engine Checks



Oil Leakage

Bearing Housing M10 x 1.25

Pipe Fitting 11/16-16 UN (19 mm)

Warning

The oil inlet is pressurized and no service action should be taken with the engine running.

Replacement seals and adapters should be fitted without sealant as this can contaminate the oil. Torque tighten adaptor to value shown in [Service Data Sheet](#).

It is important to avoid kinked pipes during servicing and subsequent operation.

M6 x 1.0

Warning

Outlet oil is hot and no service action should be taken with the engine running.

Replacement gaskets and flange fasteners should be fitted without sealant as this can contaminate the oil. Torque tighten fasteners to value specified by engine manufacturer.

All outlet pipes should be free flowing without kinks and sharp bends and decline at an overall angle not less than 30 degrees below the horizontal.

Closed crankcase ventilation systems may deposit oil in the compressor housing. Where practical remove intake system pipework every 50,000 km (30,000 miles) to check housing, compressor wheel and inlet baffle condition.

Always refer to [Cleaning of Housings](#) to clean housing. Rotor components can be cleaned using a non metallic bristle brush.

Warning

Always wear safety glasses during cleaning.

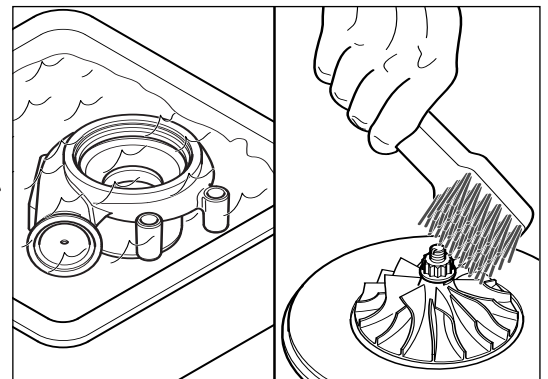
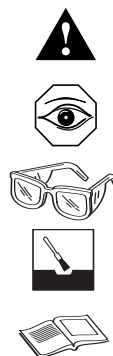
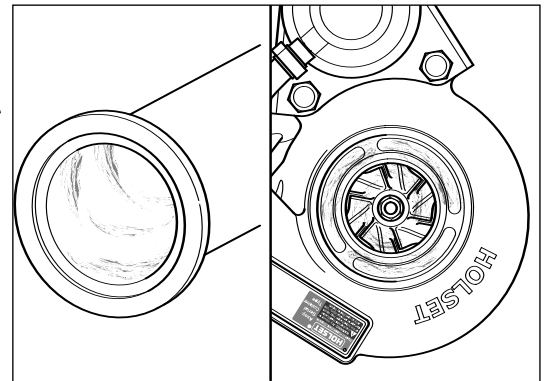
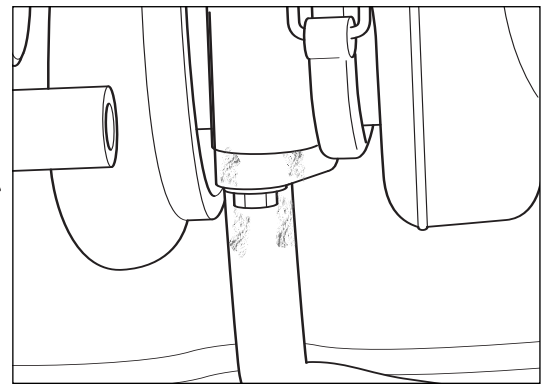
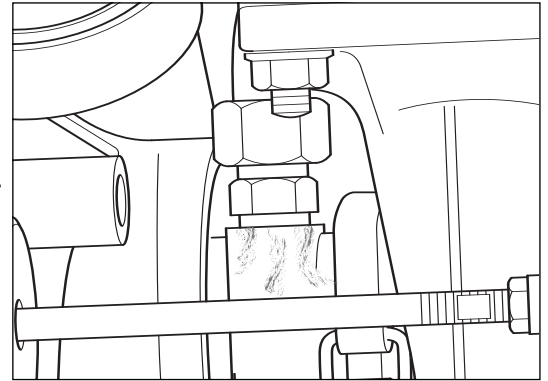



Exhaust Gas Leakage

Turbine housing flange leakage will cause soot formation on the flange. Check exhaust manifold to flange seal ensuring fastener torque meets engine manufacturer's recommendation.

Check flange for cracks and ensure flatness is within 0.1 mm (0.004 in).

Check turbine housing gasket for signs of damage which would cause leakage. Always replace damaged gaskets.

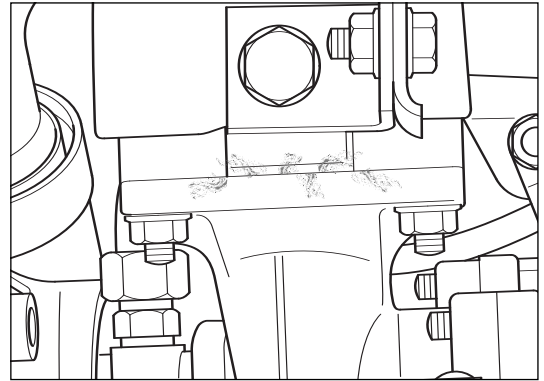

Visual Checks

Check for cracked, bent or damaged compressor wheel blades.

Caution 
Never attempt to straighten blades.

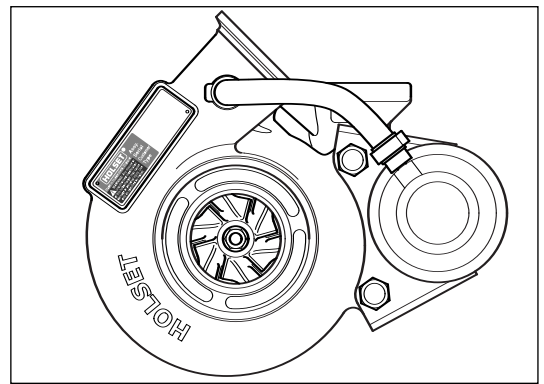

Where practical, check for cracked, bent or damaged turbine wheel blades.

Caution 
Never attempt to straighten blades.

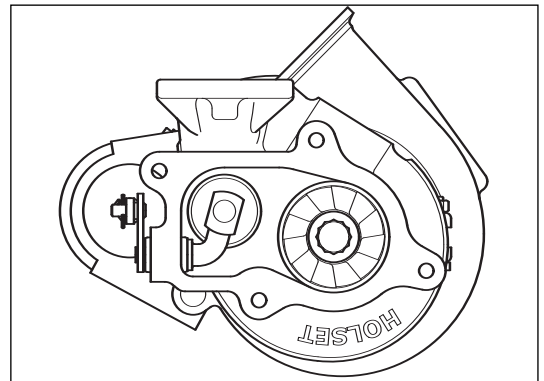

With intake system disconnected from compressor housing, it may be possible to check visually for excess bearing axial and radial clearances.

If light finger pressure causes contact between compressor or turbine wheel with respective housing, replace turbocharger.

If in doubt, the turbocharger must be removed from engine to check bearing clearance against recommended values shown in [Service Data Sheet](#).

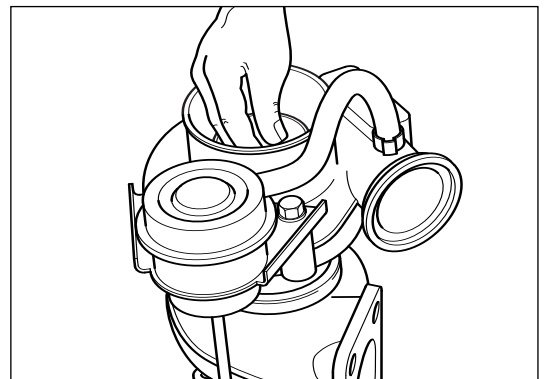
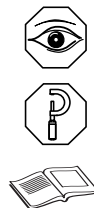

To check for wastegate actuator rod movement and air leakage on engine, follow the checking procedure described in [Wastegate Actuator Checks](#).

Warning 

Never attempt to check actuator using air supplied from a running engine.

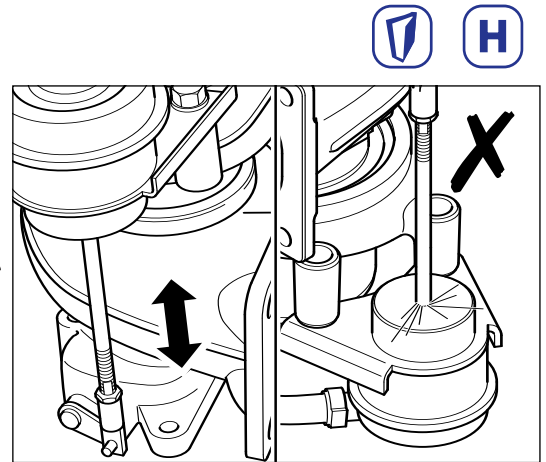

Bearing Clearance



Secure the turbine housing and check the thrust clearance using a dial gauge.

Ensure clearance is within MIN/MAX values shown on [Service Data Sheet](#).

If axial clearance does not meet specification refer to turbocharger [Service and Overhaul](#) to strip and rebuild the CHRA (core).

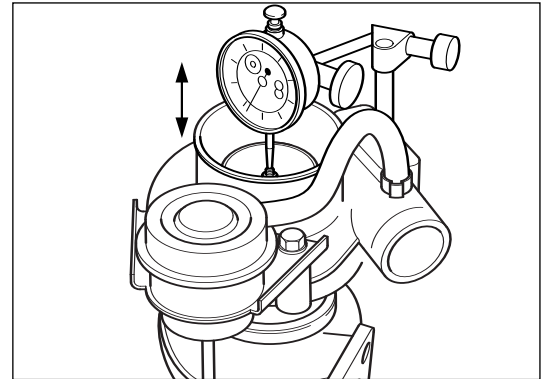

Check the radial movement at compressor impeller nose using a dial gauge.

Ensure movement is within MIN/MAX TIR (Total Indicator Reading) values shown on [Service Data Sheet](#).

If radial movement does not meet specification refer to turbocharger [Service and Overhaul](#) to strip and rebuild the CHRA (core).

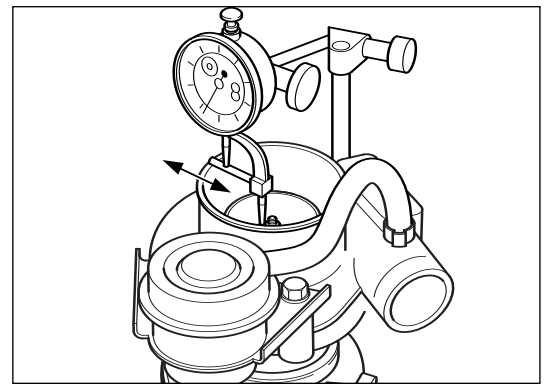

Turbine and Compressor Housings



Note

Where fitted, it is necessary to remove the wastegate actuator before removing turbine or compressor housings. Always ensure the end link is locked in the correct pre-set position before removal. Refer to [Wastegate Actuator Removal](#) for removal process.

Warning

The actuator rod may retract very quickly when freed from the lever arm. Keep fingers away from mechanism.

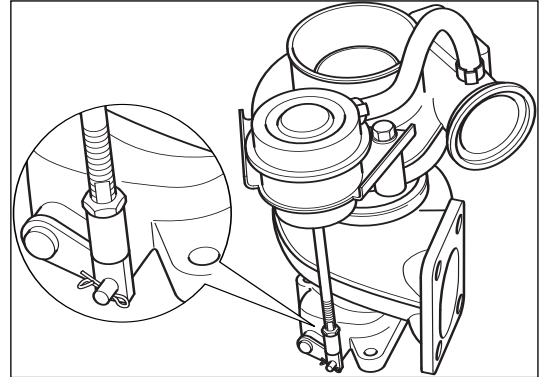

Compressor Housing

Mark compressor housing, bearing housing and retaining ring to record correct orientation. This action assists in re-assembling the pinned components and defines orientation of the retaining ring.

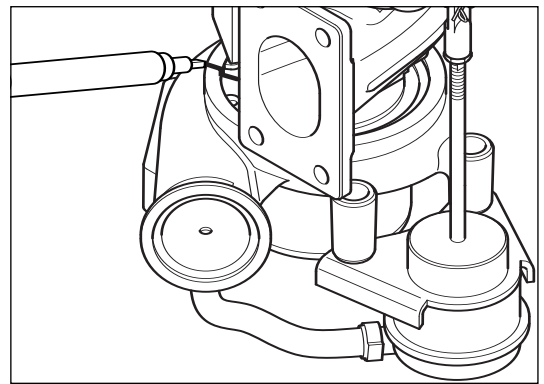

Warning

Always wear safety glasses when removing retaining ring.

Remove retaining ring, compressor housing using suitable circlip pliers.

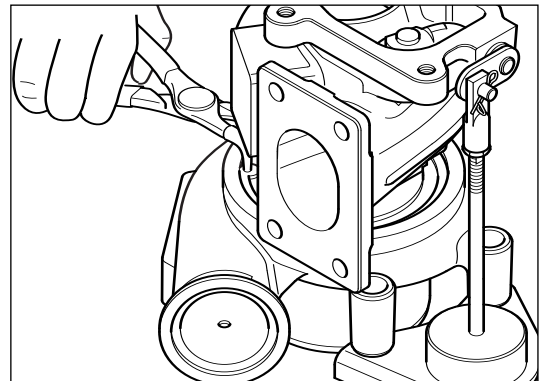
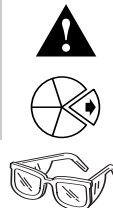

Caution

Compressor blades can be damaged easily when the compressor housing is removed. Do not bend the locating pin that aligns bearing housing and compressor housing.

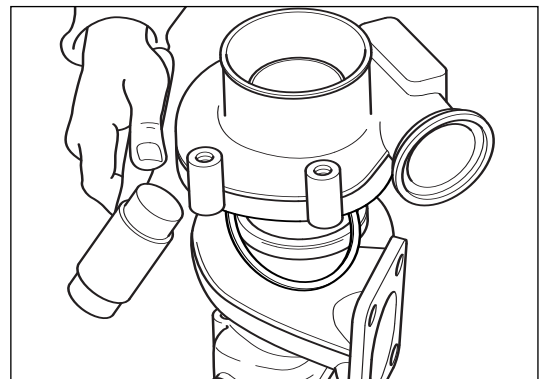
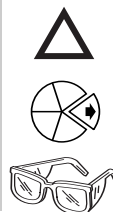

Using a soft hammer, gently tap the compressor housing off the bearing housing.



Remove the o-ring seal, compressor housing (41) and discard.

Caution 
Always fit a new seal on re-assembly.

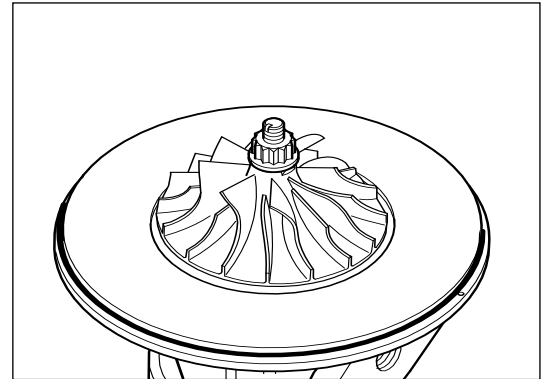

Inspect internal profile of compressor housing for scoring damage due to possible contact with compressor wheel. Check compressor cover retaining ring groove is free from deposits and is not worn.

Move to **Cleaning of Housings** if deposits are visible.

Replace housing with new if profile damage or groove wear is visible.

Caution 
Good groove and abutment face condition are critical to the integrity of compressor housing to bearing housing joint.

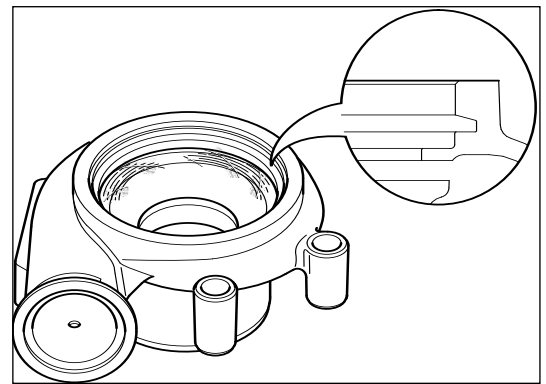
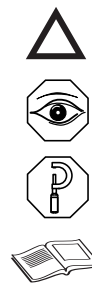

Turbine Housing

Place turbine housing outlet on a clean flat surface. Mark turbine housing, bearing housing and v-band clamp to record correct orientation. This action assists in re-assembling the pinned components and defines orientation.

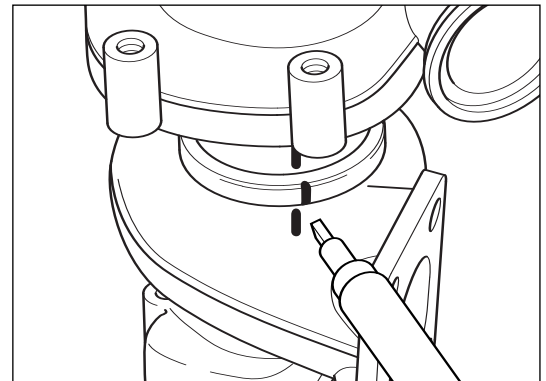

M6 x 1 (10 mm)

Loosen locknut, v-band and remove v-band, turbine.

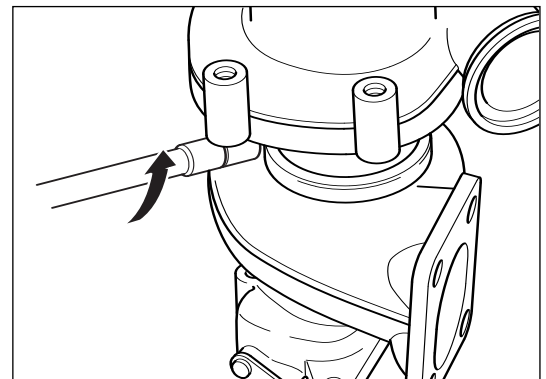



Caution

Turbine blades can be damaged easily when the turbine housing is removed. Do not bend the locating pin that aligns bearing housing and turbine housing.

Gently remove the CHRA (core) assembly from the turbine housing. If necessary use a soft hammer to free the joint.

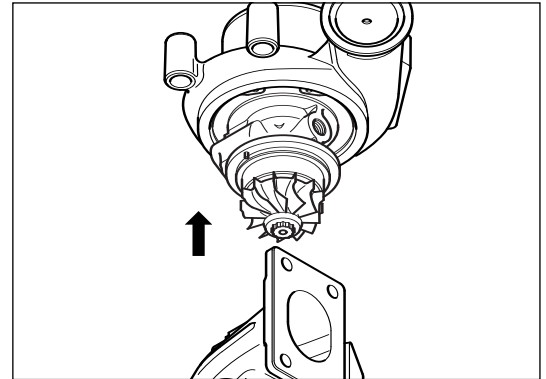

Caution

Turbine housings can exhibit cracking when subject to excessive thermal and mechanical loads.

Cracking of the turbine housing inlet flange and inlet duct generally requires turbine housing replacement. Acceptance and rejection guidelines are shown in this illustration. If an exhaust gasket is available, always ensure that any cracks lie within its sealing area

Check turbine housing inlet flange flatness is within 0.1 mm (0.004 in) before retaining component for re-use.

Check fastener hole diameter is not more than 1.5 mm larger than the max. thread diameter of the fastener.

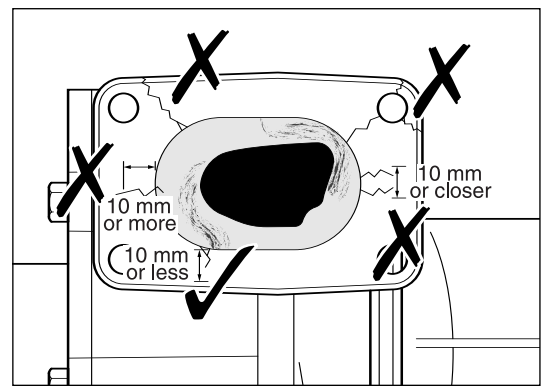

Caution

Where a crack will cause leakage to atmosphere the turbine housing must be replaced.

Cracking of the internal wall at the entry to the turbine wheel (tongue) is an acceptable service condition and the turbine housing may be re-used.

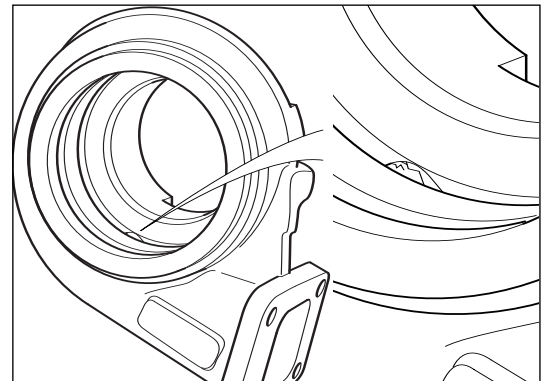

Cleaning of Housings



Visually inspect the parts to detect signs of burning and other conditions in order to obtain as much information as possible before washing.

Caution 

Surfaces adjacent to turbine and compressor wheels on the stationary housings must be clean, smooth and free from deposits.

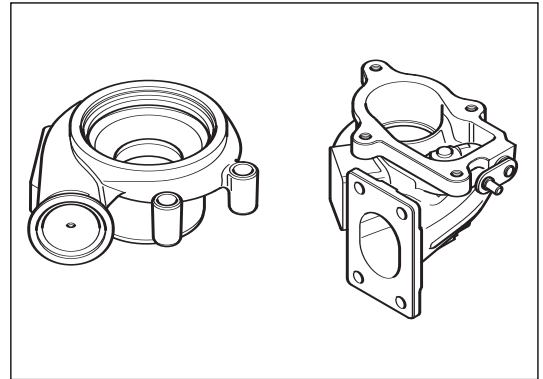

Warning 

Always wear safety glasses during cleaning.

Soak the housings in a non-corrosive low flash point metal cleaner to loosen deposits.

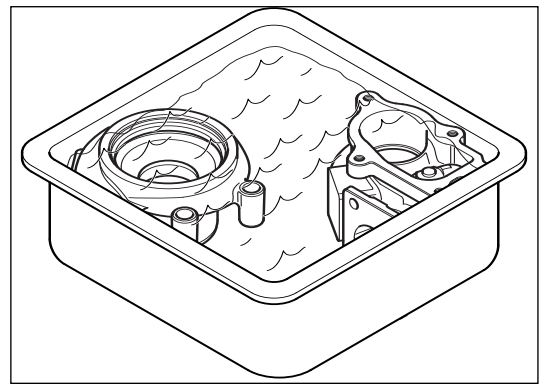

Dry the components using compressed air.

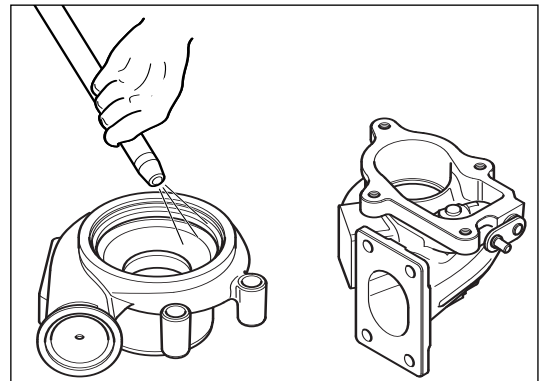

Scale like deposits, if any, must be removed by using a non metallic bristle brush. After removing the deposits, re-wash and dry the components.

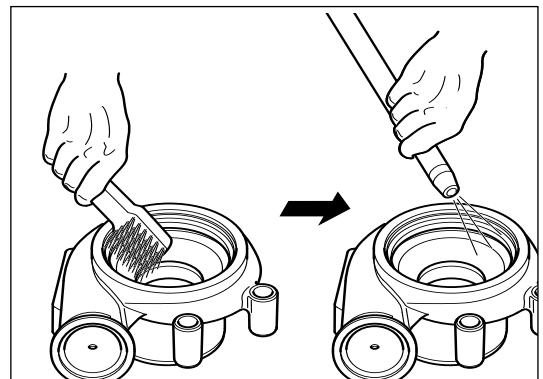



It is permissible to bead blast the turbine housing if chemical and brush cleaning is not effective.

Warning

Always wear safety glasses during cleaning.

Warning

Do not bead blast Aluminium and Cast Iron components together.

Caution

Prevent the bead spray impinging directly on turbine flange threads by masking or plugging.

Caution

Prevent the bead spray impinging directly on the wastegate valve spindle (where fitted) as beads can penetrate the spindle bore, leading to spindle seizure.

After removing the deposits, re-wash and dry the components.

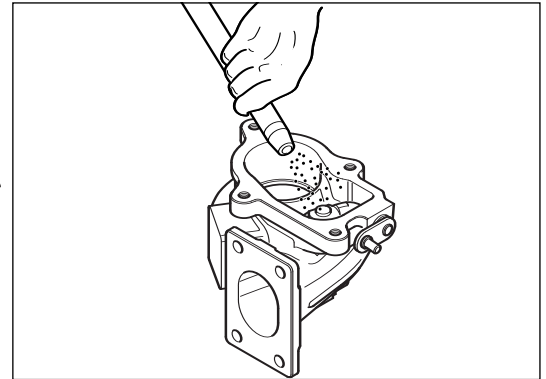

Reassembly of Housings



Turbine Housing

Align marks applied to turbine housing, bearing housing and v-band clamp to establish component orientation. This action assists in re-assembling the pinned components.

Warning

Always wear safety glasses when refitting housings.

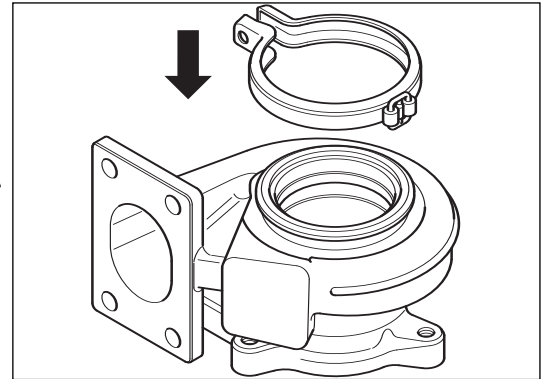

Caution

To protect compressor wheel blades, always assemble the compressor housing to CHRA (core) before refitting turbine housing.

Install CHRA (core) assembly to turbine housing making sure that it is correctly located on the alignment pin fitted to turbine housing.

Caution

The turbine wheel blades can easily be damaged when the CHRA (core) is installed.

Caution

Be careful not to bend the location pin during assembly

M6 x 1.0 (10 mm)

Locate v-band to orientation marks and apply molycote anti-seize compound to the v-band screw threads. Insert screw and apply locknut. Torque tighten to value specified in [Service Data Sheet](#).

Using a soft faced hammer, tap the v-band clamp three or four times at equally spaced distances around its circumference.

Re-tighten to specified torque.

Check for free rotation of the rotor assembly.

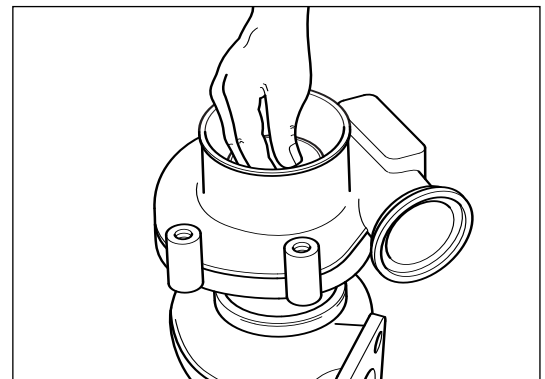
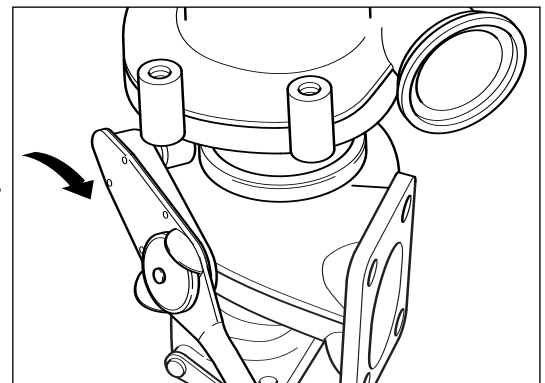
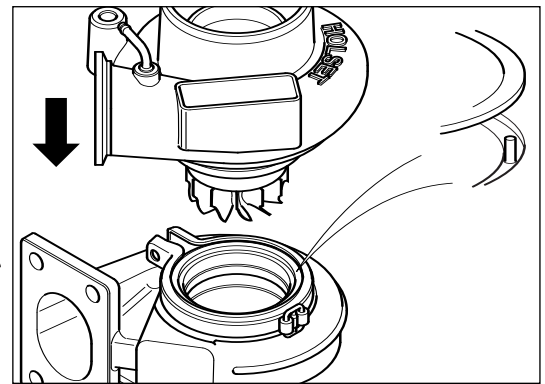



Compressor Housing

Lubricate new o-ring seal with clean engine oil and insert into bearing housing groove.

Caution

Always fit a new seal on re-assembly.

Caution

Compressor blades can be damaged easily when compressor housing is being refitted.

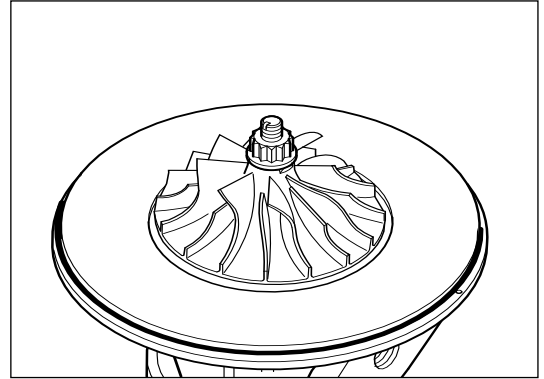

Position retaining ring, compressor housing over the bearing housing with the chamfered face towards the turbine housing. Correctly align compressor housing using disassembly orientation marks to ensure location pin aligns with mating hole in bearing housing. Press compressor housing into position taking care not to trap o-ring.

Note

Where the turbine housing is not already fitted to CHRA (core), the compressor housing should be placed on its inlet face. The CHRA can then be inserted using the technique already described.

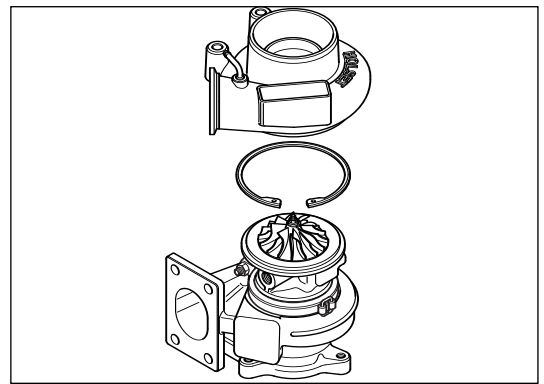

Turn turbocharger on to compressor inlet face. Refit retaining ring, compressor housing using suitable circlip pliers.

Warning

Always use safety glasses when inserting retaining ring.

Caution

The retaining ring must be fitted with the chamfered face upwards away from the compressor housing.

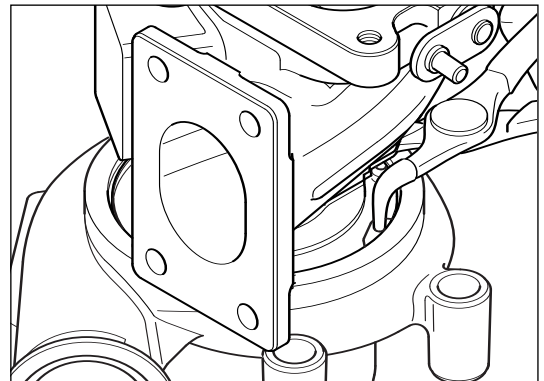

Tap ends of retaining ring lightly with hammer and drift to ensure that the retaining ring is properly located into its groove in the bearing housing.

Caution

Ensure that drift does not damage bearing housing during this operation.

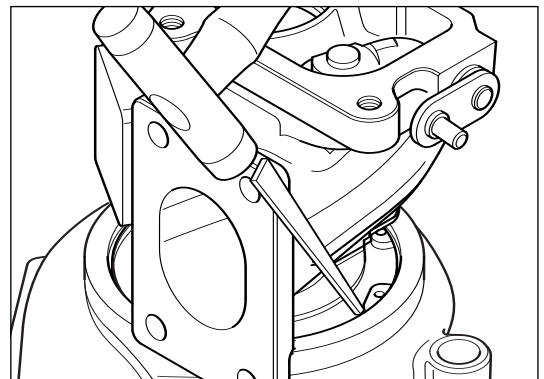



Check for free rotation of the rotor assembly.

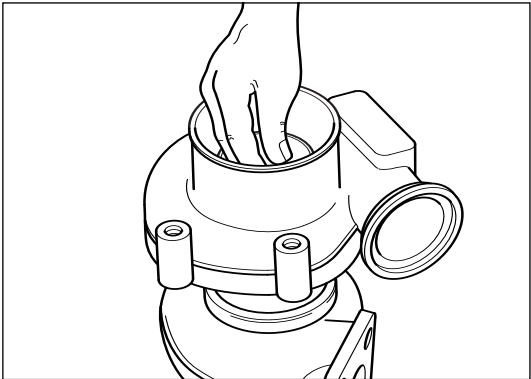

Wastegate Actuator Checks



Caution

Do not remove turbocharger from engine unless an actuator check is impractical due to space or access limitations or where an on-engine check has shown a problem exists.

Warning

Wear safety glasses at all times during the disassembly process.

Place the turbocharger on a suitable workbench. Using a small flat screwdriver, carefully remove the hose clip (75) and discard. Pull the flexible hose from the actuator spigot.

Connect and secure the hose from a regulated compressed air supply to the actuator spigot.

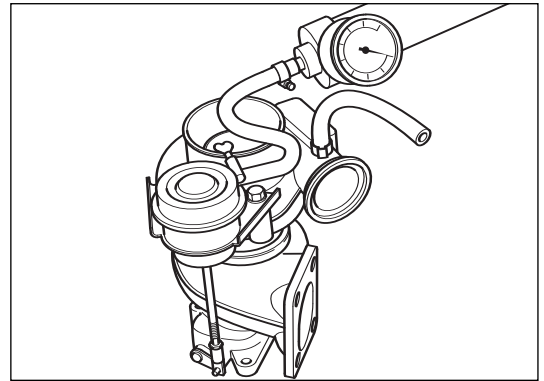
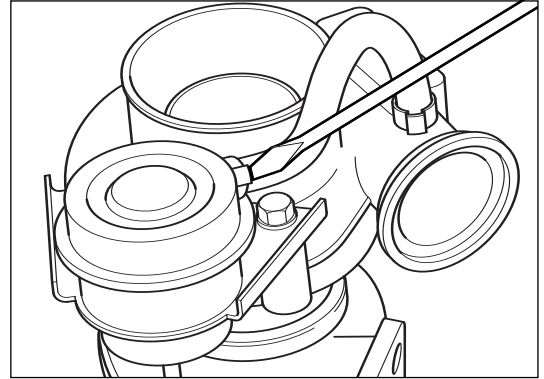
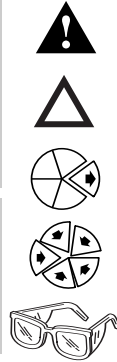

Warning

Avoid touching the wastegate rod end area as finger injury may result from sudden movement of the assembly when air pressure is applied.

Carefully apply pressure to the actuator from the regulated compressed air supply Max 300 kPa (45 lbf/in²) and check for actuator movement.

If movement is confirmed when using remote air supply check that turbocharger hose assembly is not damaged. If damage is found, replace with new hose and clips.

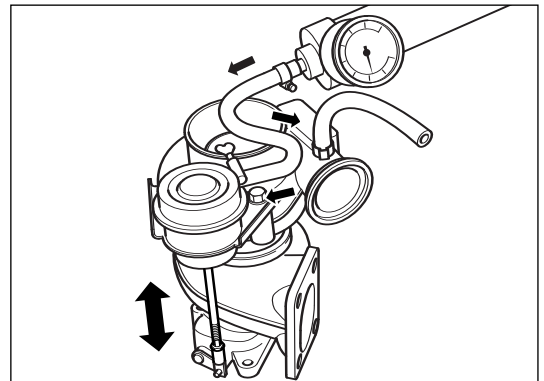

Seized Actuator Check

If rod does not move check wastegate actuator for air leaks. If no air leak is found and rod does not move, check valve mechanism for seizure according to procedure defined in [Wastegate Mechanism Check](#).

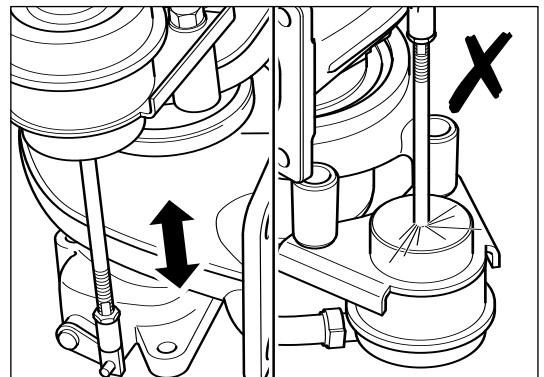

Actuator Removal



Warning

Wear safety glasses at all times during the disassembly process.

Carefully remove the actuator clip using point nose pliers.

Caution

Do not rotate actuator rod relative to actuator as this can damage actuator internal components.

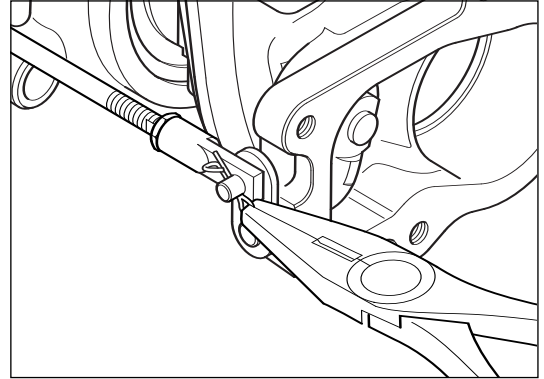
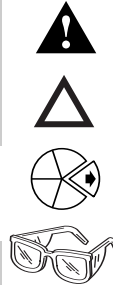

Warning

The rod may retract very quickly when freed from lever arm. Keep fingers away from mechanism.

Gently apply a small amount of air to the actuator and when/if the rod end moves, carefully slide the end link off the valve lever arm. If the actuator rod does not move, a screw driver may be required to prise the end link off the lever arm.

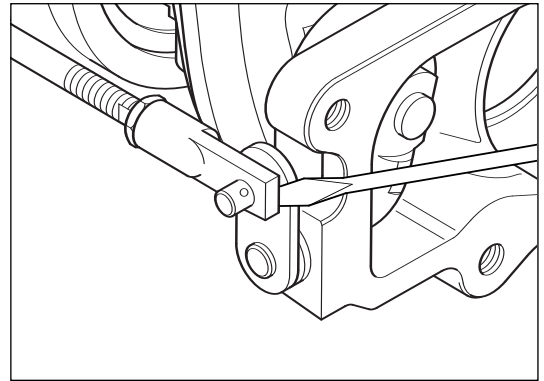

M8 (12 mm)

Remove actuator fasteners and remove wastegate actuator.

Caution

Do not adjust the wastegate rod end link. This setting is critical to actuator performance.

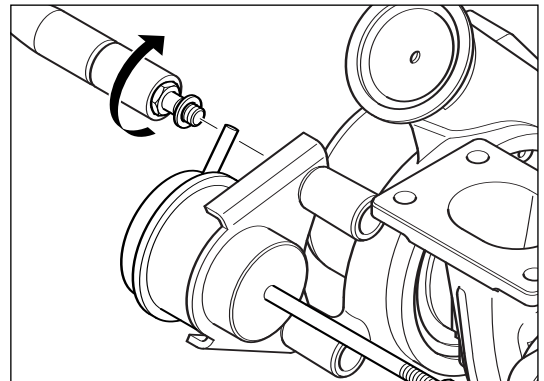
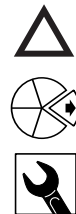

Wastegate Mechanism Check



Carefully move the lever arm up and down. If the arm moves freely by hand, then re-check for movement of actuator rod.

Apply an air pressure of 300 kPa (45 lbf/in²) to the actuator spigot inlet. If the rod does not move, replace the actuator with a pre-set replacement kit (74).

If the lever arm is seized, the turbine housing will require replacement. However, it may be possible to free the lever arm.

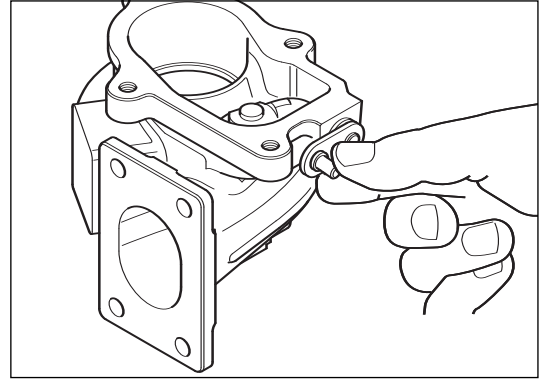

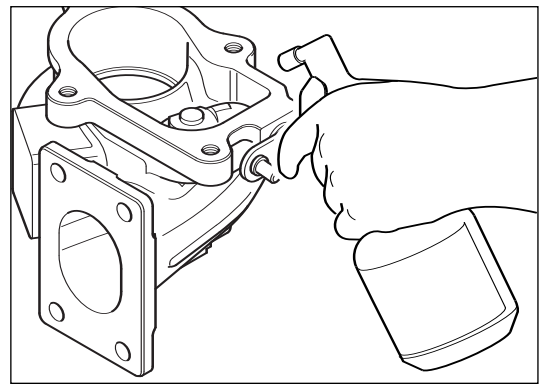

Soak wastegate valve and lever mechanism in penetrating oil.

Warning 
Always wear safety glasses.

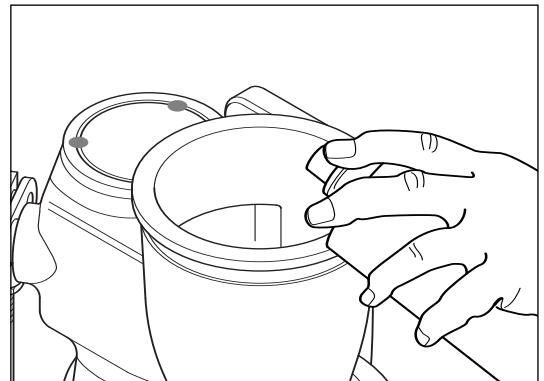

Some turbine housing options do not have open access to the wastegate valve but, with care, soaking with penetrating oil may still be possible.



Caution 
Extra care must be taken when attempting to free the valve mechanism. Any damage will result in the replacement of the turbine housing.

Clamp a pair of mole (vice) grips to the lever and gently apply pressure to rotate the lever arm in an arc.

If this process does not free the lever, pin and valve mechanism, a new turbine housing must be fitted.

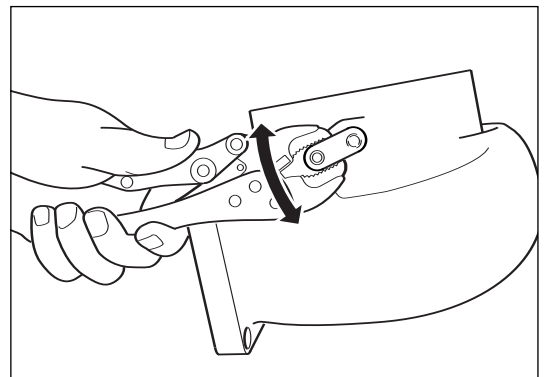



Caution  If the wastegate valve mechanism shows any fault, it must be replaced. Using damaged turbine housings will lead to inferior performance of the turbocharger, and risk of irreparable damage to both turbocharger and engine.

Radial cracks can occur around the valve seat when the turbocharger has been abused or overheated.

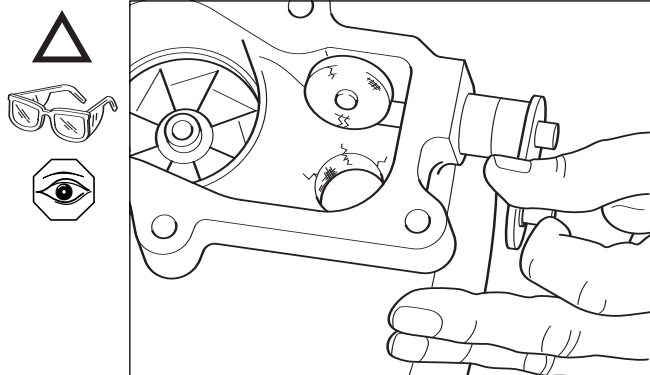

Lever arm pin can be worn by partial seizure of the valve mechanism. Scoring may be caused by arduous local environmental conditions.

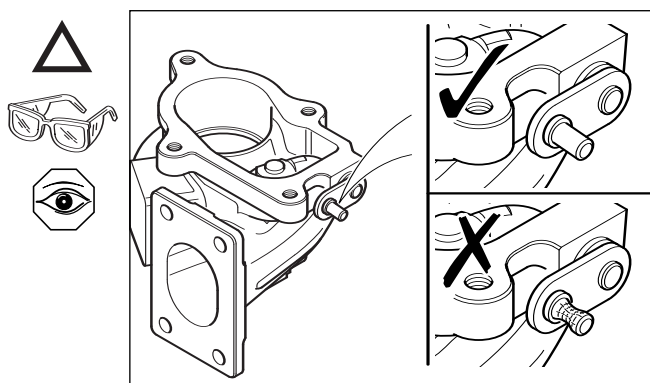

The same failure conditions can also lead to elongation of the actuator rod bore which locates on the lever arm pin. This must not exceed 0.5 mm (0.020 in).

Caution  If the actuator shows any fault, it must be replaced.

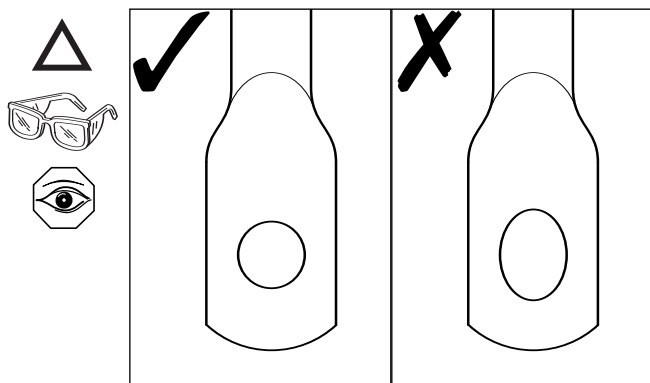

Wastegate Actuator Replacement



Caution

Contact your local approved agent for the correct replacement actuator kit (74). It is important to quote the correct turbocharger assembly number to ensure supply of the correct pre-set actuator.

Note

When refitting existing actuator the end link will be locked in the correct setting.

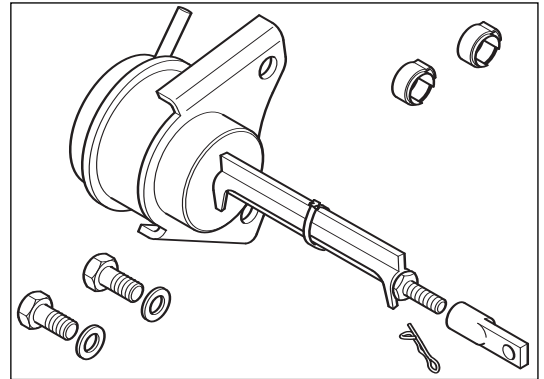

Thread new end link several turns on to the shaft of the new pre-set actuator assembly.

Hold the actuator assembly with the spine of the spacer piece upright. Rotate the valve mechanism lever arm to close the wastegate valve (pushed towards the compressor end). Fit end link over the lever arm pin.

Attempt to slide the actuator bracket over its retaining lugs. If the actuator bracket fouls on the lugs or there is significant clearance between bracket and lugs, actuator rod length requires adjustment.

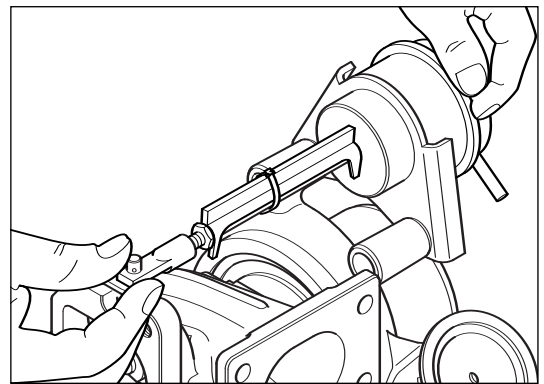

To adjust the length of the actuator assembly, remove from the turbocharger. Rotate the end link to shorten or lengthen the rod as appropriate. Re-fit, until the underside of the actuator bracket will just fit over the mounting lugs with less than 0.5 mm (0.020 in) gap.

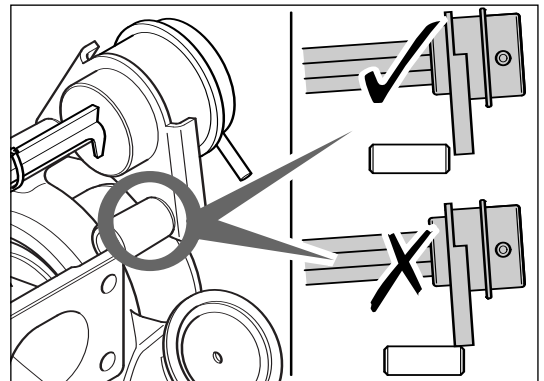

Caution

Do not apply force to push the actuator on to its mounting lugs.

The rod length setting is correct if, by rotating end link clockwise by a half turn, the actuator bracket fouls on the lugs.

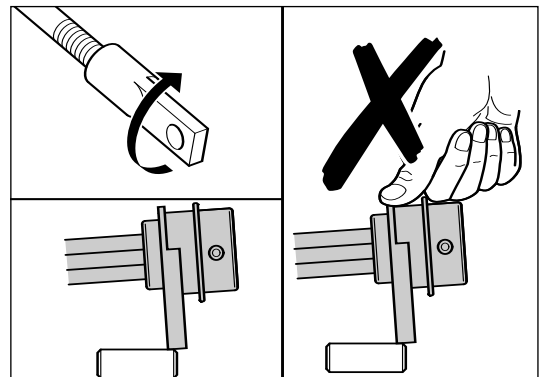



M8 (12 mm)

Fit actuator mounting fasteners with washers and torque tighten to the value shown in the [Service Data Sheet](#).

Warning

Always wear safety glasses when fitting wastegate actuator.

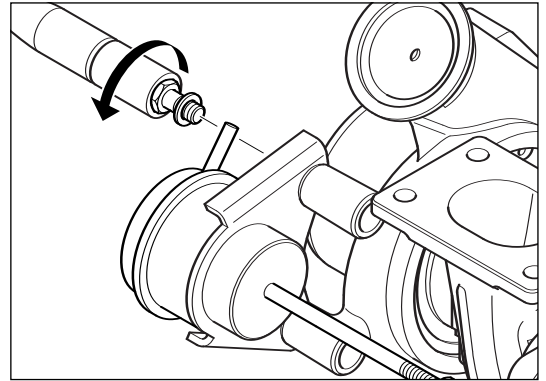

Fit new spring clip to retain end link on pin.

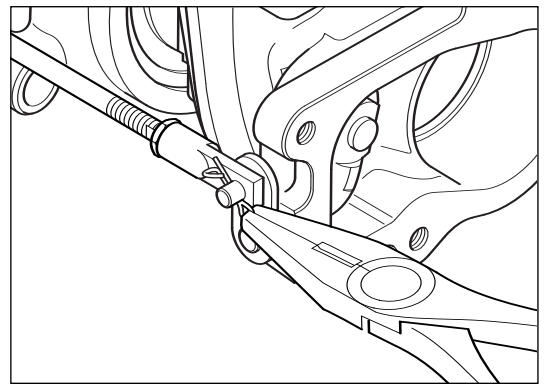
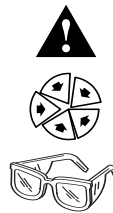

(10 mm)

Loosen spacer piece by turning jam-nut anti-clockwise (counter-clockwise). Remove and discard tie wrap and spacer piece.

Continue turning jam-nut in the same direction, and torque tighten against end link to value shown in [Service Data Sheet](#).

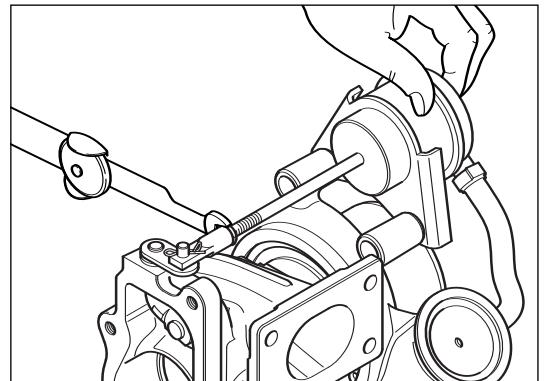

New pre-set actuator kits (74) may be supplied with a tamper resistant break off nut (143) instead of a jam nut (128). To install a tamper resistant actuator:

1. Slacken the shear nut from the spacer spine
2. Continue to turn the nut until it contacts the pre-set end link
3. Continue tightening until the hex flats break off leaving only the cone section in tight contact with the end link.

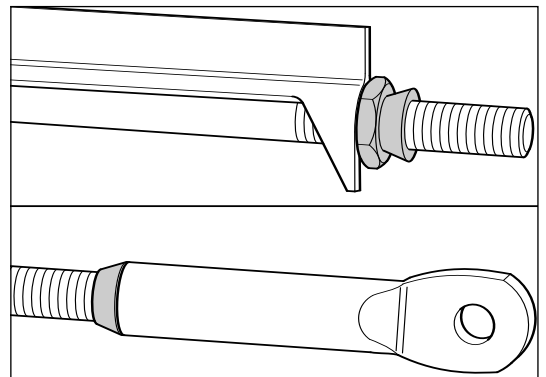



Refit the air supply hose with new clips (75). Clips should be crimped closed using pinners. Crimp gap will vary due to spring back and hose type but will not be less than 0.6 mm (0.025 in).

Suitable alternative hose clamps can be used.

Caution 

Before mounting turbocharger on engine, check for full and free wastegate movement.

Caution 

Ensure that air feed pipe is free from kinks and has no chafe marks.

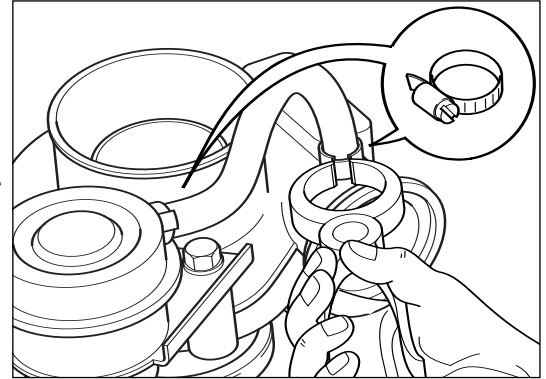

Service Tools



The following special tools are recommended to perform procedures in this manual. The use of these tools is shown in the appropriate procedure. These tools can be purchased from your local Authorised Repair Location.

Part No.	Tool Description	Tool Illustration
	Torque Wrench	
	Dial Gauge and Dial Gauge Adaptor	
	Pressure Gauge Regulated Air Supply Max 300 kPa (45 lbf/in ²)	

Caution

All Service and Maintenance settings are shown in Holset's Service Data Sheet. It is essential that these settings are used. Common tools found in mechanic's tool box not included.

Disassembly



Note

Before disassembly, check for turbine and compressor blade damage. Measure bearing radial movement and axial clearance to ensure the CHRA (core) is within the MIN/MAX values shown on [Service Data Sheet](#).

Warning

Always wear safety glasses during disassembly.

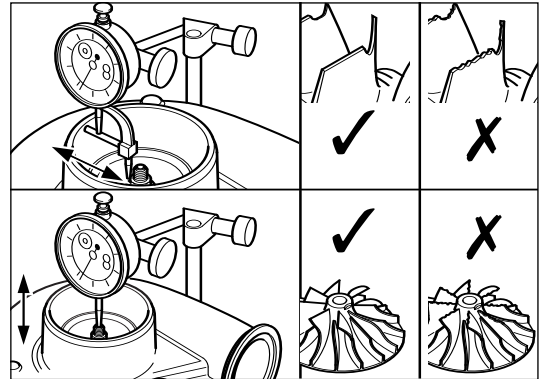

Caution

This turbocharger requires a new standard of balancing process on rebuild using a proprietary vibration sorting rig (VSR). Do not scribe alignment marks for rotor balancing.

Locate the CHRA (2) on to a 12 mm 12 point socket located in a suitable fixture.

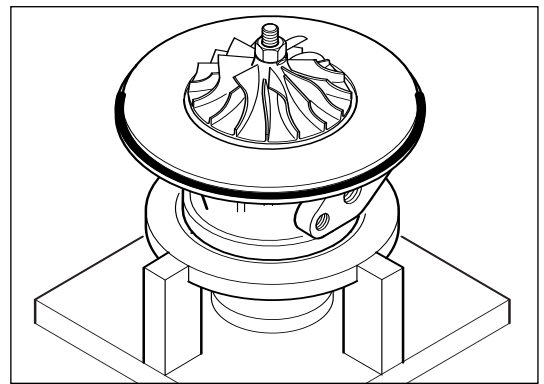
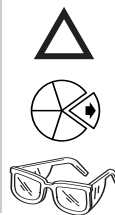

M5 x 0.8 L.H. (8mm)

Remove the locknut, compressor wheel (62).

Note

Left hand thread.

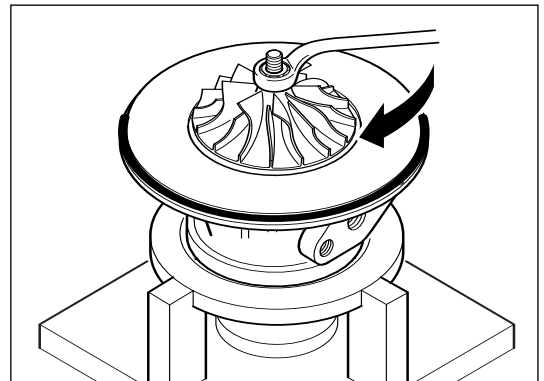
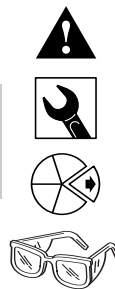

Remove compressor wheel (7).

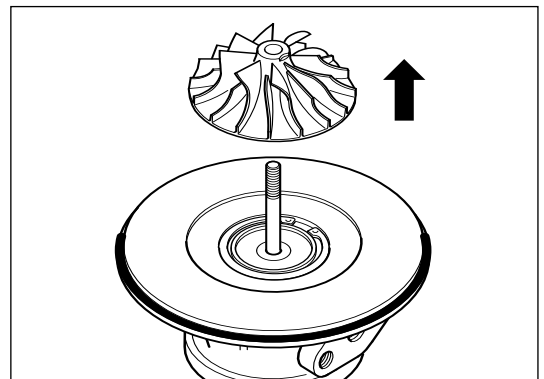



Remove remaining CHRA from fixture taking care to hold assembly, turbine wheel in place. Gently slide bearing housing (4) off the assembly, turbine wheel (6).

It is permissible to tap the protruding turbine shaft gently with a soft hammer if the split ring seal is stuck in its bore.

The turbine end journal bearing and heat shield disassemble from the core at this stage.

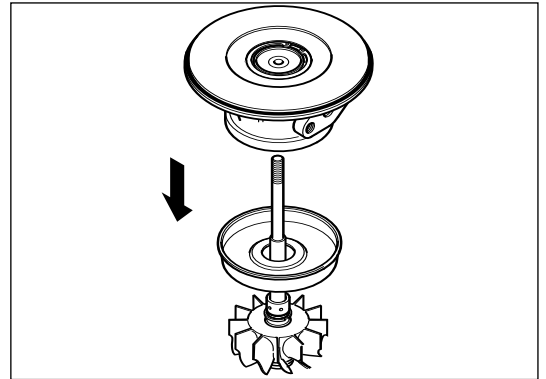

Remove journal bearing (11) and heat shield (38).

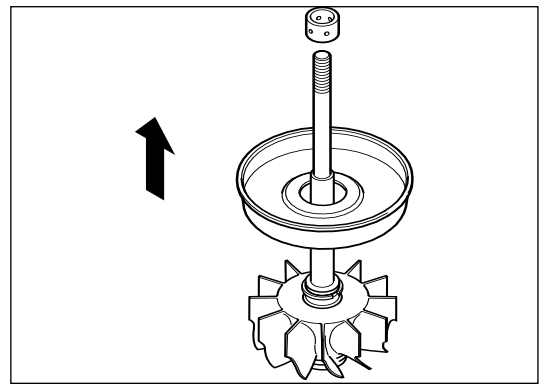

Carefully remove the split ring seal, turbine (13) * and discard.

Warning 

Always wear safety glasses when removing sealing rings.

Caution 

Care should be taken not to score the assembly, turbine wheel.

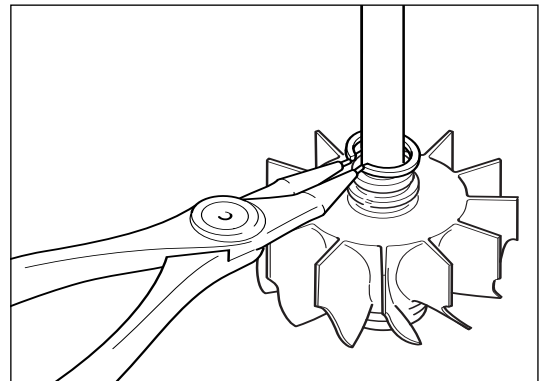

With bearing housing (4) on a flat clean surface, use suitable circlip pliers to remove insert, retaining ring (66).

Warning 

Always wear safety glasses when removing retaining rings.

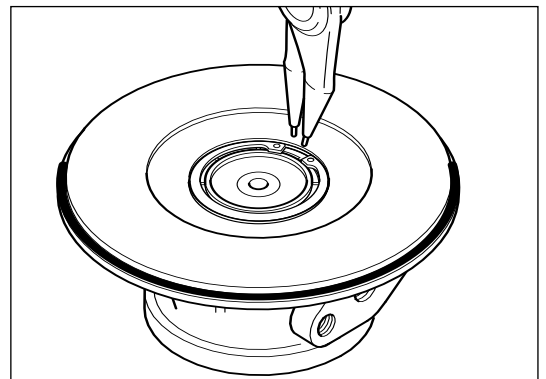

It is practical to use free hand to contain disassembled ring whilst releasing pliers.



Remove oil seal plate (43) using two screw drivers under the exposed lip to prise out seal plate.

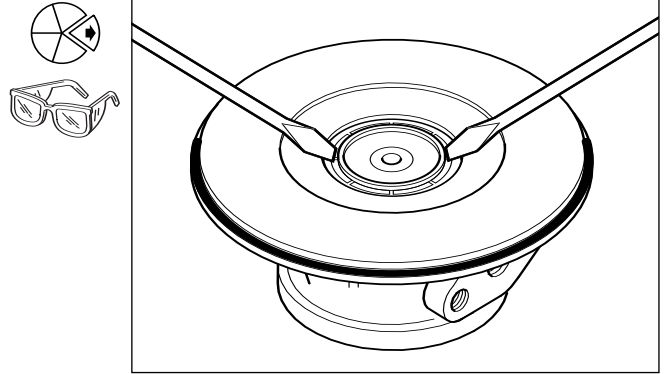

Remove oil slinger (31) and baffle sub-assembly from oil seal plate.

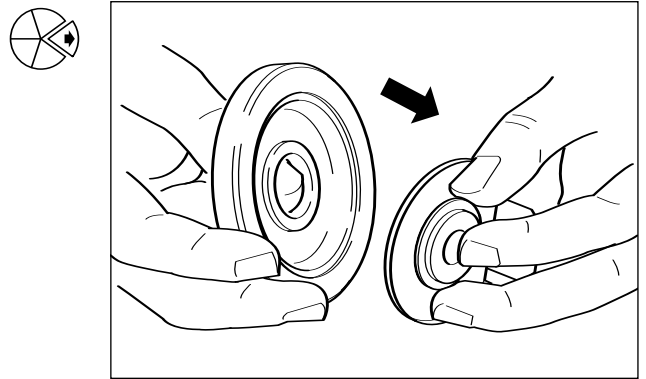

Using a precision screwdriver, remove split ring seal, compressor (16) * to disassemble oil slinger (31) from oil baffle (33) *.

Warning

Always wear safety glasses when removing sealing rings.

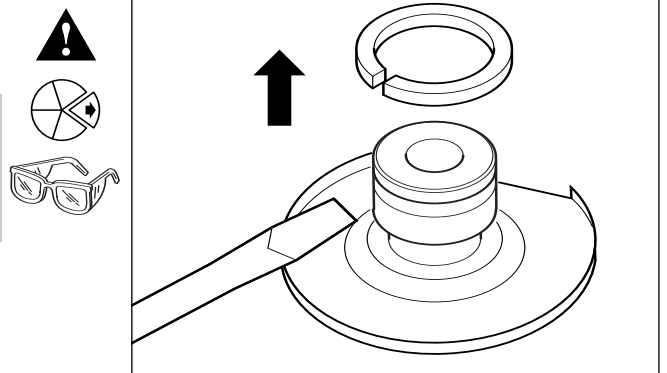

Remove and discard the o-ring seal, bearing housing (32) * and o-ring seal, compressor housing (41) *.

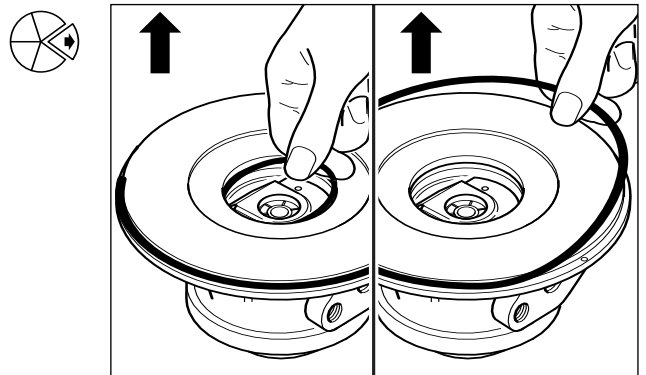



Turn bearing housing over so that thrust bearing (12) *, thrust collar (36) and the compressor end journal bearing (11) * drop out of assembly under own weight.

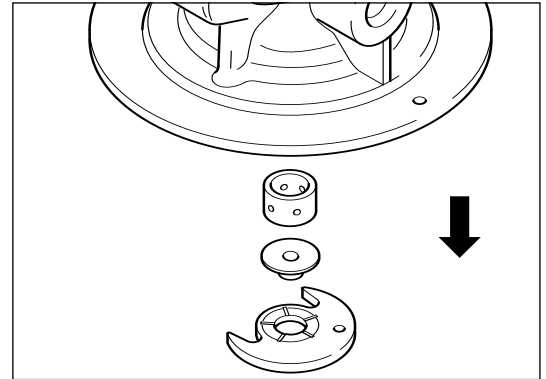

Note

If these stick in position use a screwdriver inserted at turbine end to dislodge.

Inboard bearing retaining rings are intended to remain in the housing. Where removal is essential bearing bore damage can be avoided by locating a precision screwdriver under the angled end of the ring to lift it out of the groove. Then use a rotary motion until the 1¹/₂ coils of the ring come clear of the groove.

When removal is essential, it is acceptable to replace proprietary rings with equivalent circlips.

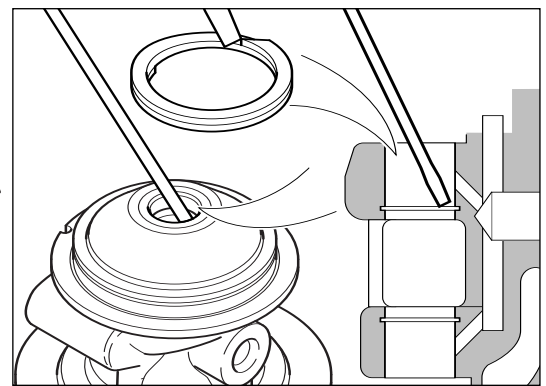
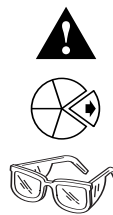

Warning

Always wear safety glasses when removing or inserting retaining rings.

Replacement of the original type of spring ring can be accomplished by pre-compressing the rings into a thin walled tube with an external diameter equal to minimum bearing bore size. Place the tube through the bearing bore with the end face adjacent to a ring groove. Push the spring ring out of the end of the tube to allow it to expand into its location.

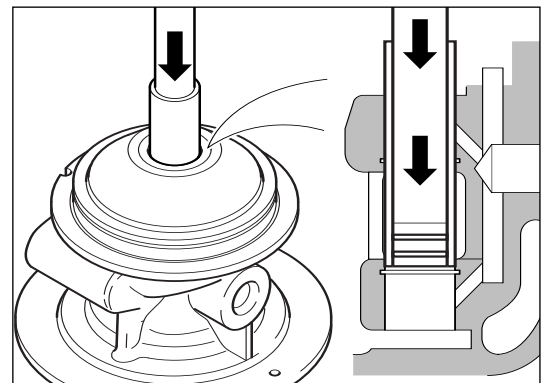

Component Cleaning



Visually inspect all parts to detect signs of burning and other fault conditions in order to obtain as much information as possible before washing.

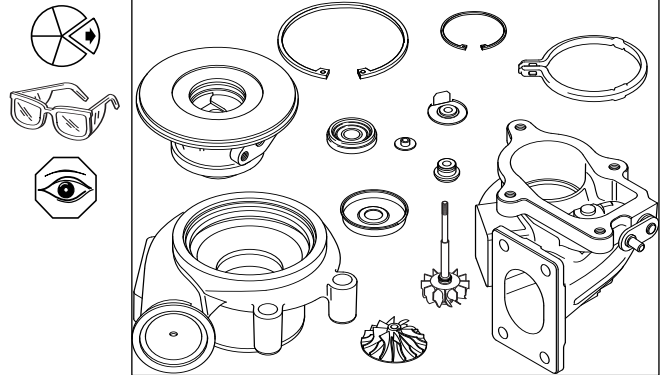

Soak the components in a non-corrosive low flash point metal cleaner to loosen deposits.

Warning

Always wear safety glasses during cleaning.

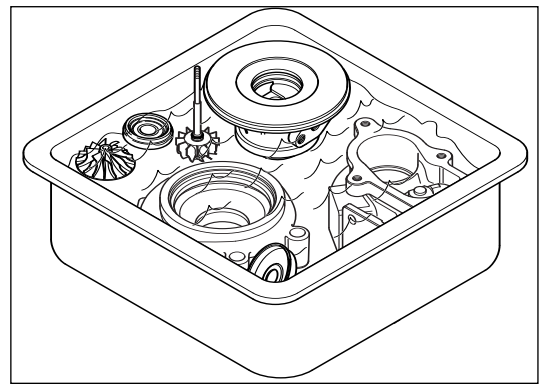

Dry the components using compressed air.

Protect the sliding surfaces of the cleaned parts against corrosion by applying clean engine oil.

Warning

Always wear safety glasses during cleaning.

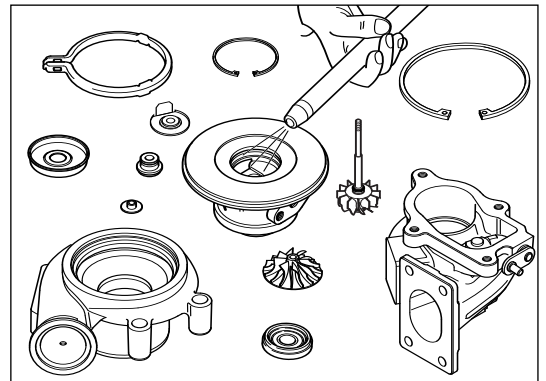

Scale like deposits, if any, must be removed by using a non metallic bristle brush. After loosening the deposits with the brush, wash and dry components as above.

Warning

Always wear safety glasses during cleaning.

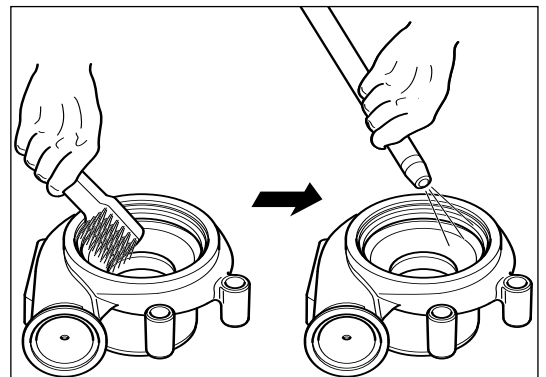
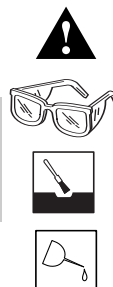



Warning ⚠

Do not bead blast aluminium and cast iron components together.

It is permissible to bead blast the turbine housing if chemical and brush cleaning is not effective.

Caution ⚠

The surface adjacent to the turbine and compressor wheels on the stationary housings must be clean, smooth and free from deposits. Always protect threads during bead blasting and clean with the specified thread tap after blasting. Prevent the bead spray impinging directly on the wastegate valve spindle (where fitted) as beads can penetrate the spindle bore, leading to spindle seizure.

It is important that the oil chamber of the bearing housing is free of carbon before re-building. If heavy deposits persist after repeat washing replace bearing housing (4).

Caution ⚠

Do not bead blast the bearing housing as this may damage critical bearing surfaces.

It is permissible to bead blast steel rotating parts.

Caution ⚠

Blasting specific areas for long periods of time may affect component balance. Protect thread of turbine wheel assembly.

Caution ⚠

Always clean components with compressed air after blasting.

Warning ⚠

Always wear safety glasses during cleaning.

Caution ⚠

Do not bead blast the aluminium compressor housing as this may damage critical surfaces.

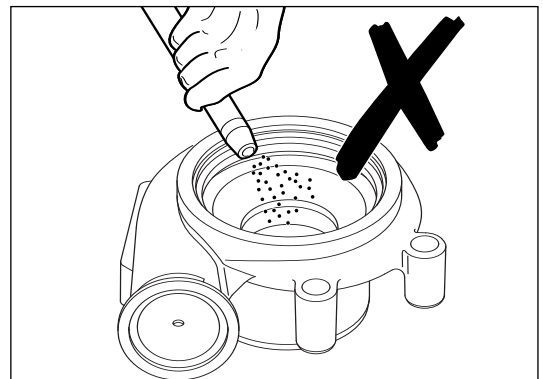
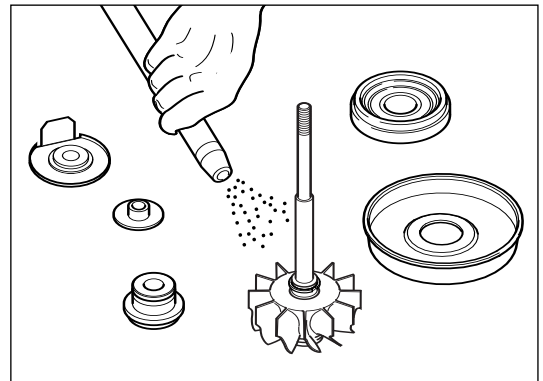
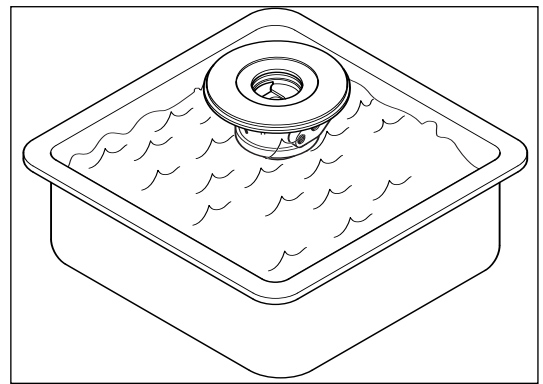
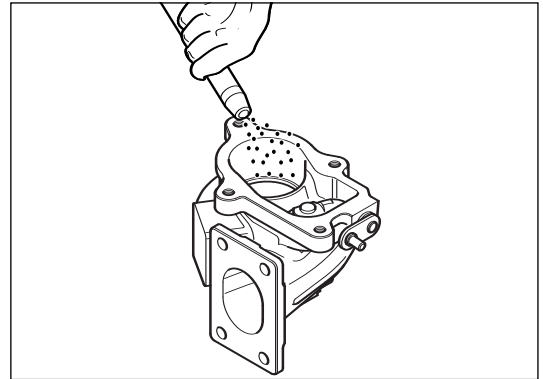

Inspection and Testing



Major Components

Assembly Turbine Wheel

Place assembly, turbine wheel (6) on a vee block. Position a dial gauge on the turned surface of the shaft at the threaded end. Check dial gauge reading. Where shaft bend is greater than the recommended maximum of 0.015 mm (0.0006 in) replace the assembly.

Caution

Do not attempt to straighten the turbine shaft.

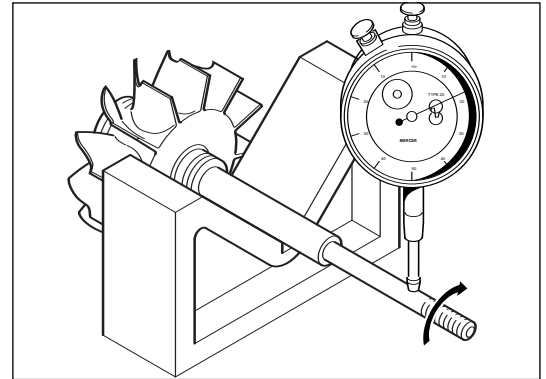

Inspect split ring seal, turbine (13)* groove walls for wear. If there is any evidence of wear or damage replace assembly.

If the wear step on the ring face exceeds 0.102 mm (0.004 in) replace split ring seal, turbine.

If the free gap of the ring is less than 2.0 mm (0.08 in) replace split ring seal, turbine.

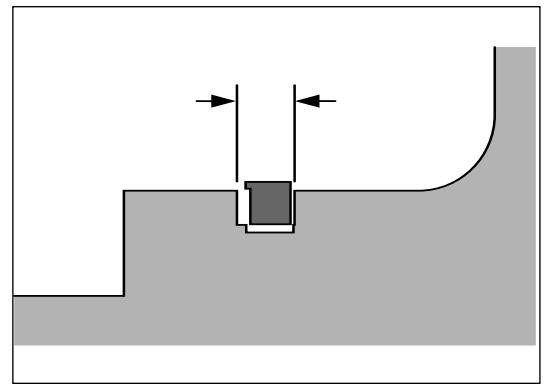

Inspect the bearing journals for excessive scratches and wear. Where scratching is excessive or where either journal diameter is less than the recommended minimum of 7.53 mm (0.296 in) replace the assembly.

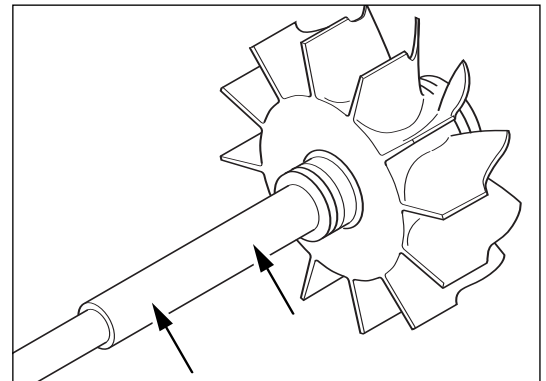

Inspect for cracked, bent or damaged blades.

Caution

Never attempt to straighten blades.

Replace with new if any damage found.

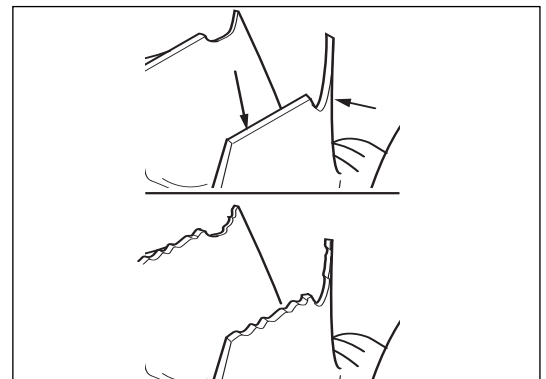



Compressor Wheel

Inspect compressor wheel (7), for cracked, bent or damaged blades.

Caution Do not attempt to straighten blades.

Replace with new if any damage found.

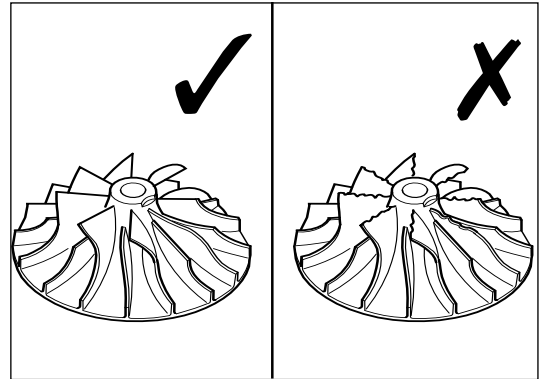

Compressor Housing

Inspect internal profile of compressor housing (8), for scoring damage due to possible contact with compressor wheel. Check retaining ring, compressor housing (91) groove is free from deposits.

Return to [Component Cleaning](#) if deposits remain.

Replace with new if profile damage is visible.

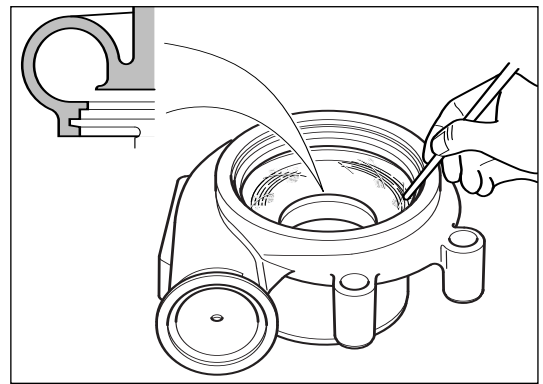

Ensure position of compressor housing retaining ring groove has not been compromised by wear.

Caution Good groove and abutment face condition are critical to the integrity of compressor housing to bearing housing joint.

Check bearing housing location pin is not bent or loose. Replace if damaged.

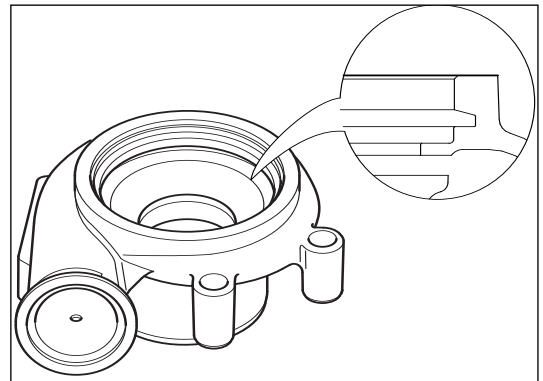

Turbine Housing

M8 x 1.25 (13 mm)

Check bearing housing location pin is not bent or loose. Replace if damaged.

Inspect the turbine housing (5) profile for damage caused by possible contact with the rotor. Inspect the outer and internal walls for cracks or flaking caused by overheating.

Check turbine housing inlet flange flatness is within 0.1 mm (0.004 in). Check flange threaded holes with an M8 x 1.25 thread gauge.

Replace with new if any of the above features are non compliant.

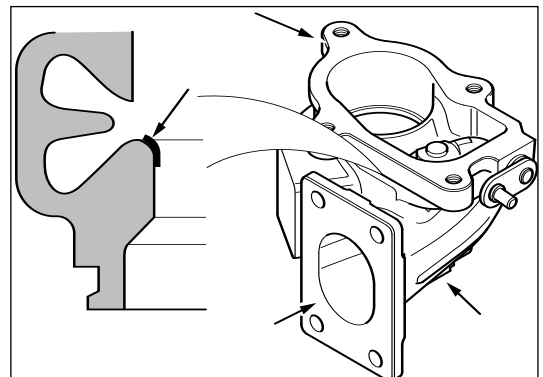



After washing and bead blasting the wastegate valve mechanism may remain seized or stiff to operate. If so, soak the mechanism in penetrating oil for approximately 20 minutes or a period of time recommended by the oil manufacturer.

Access to the valve mechanism via the turbine housing outlet can be restricted but, with care, soaking with penetrating oil is possible.

Warning

Always wear safety glasses.

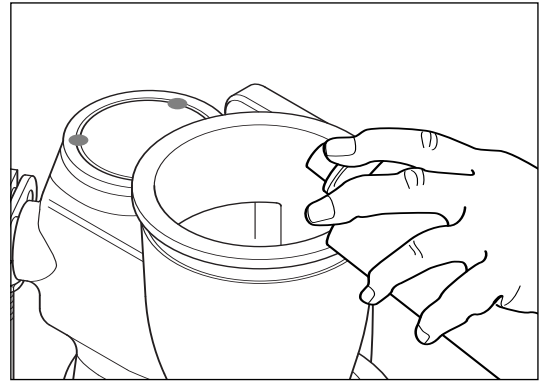

Caution

Extra care must be taken when attempting to free the valve mechanism. Any damage will result in the replacement of the turbine housing.

Clamp a pair of mole (vice) grips to the lever and gently apply pressure to rotate the lever arm in an arc.

If this process does not free the valve mechanism, a new turbine housing must be fitted.

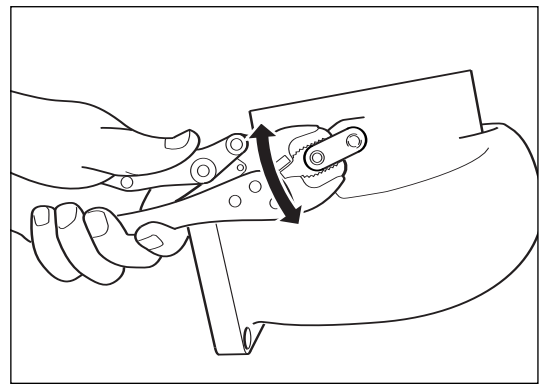
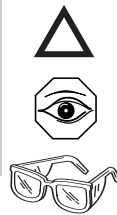

Check the wastegate lever arm for evidence of rubbing or cracking. Check the lever arm pivot for evidence of fretting damage, wear or cracking. Check the lever arm for cracking and or misalignment due to mechanical damage.

Replace with a new turbine housing if damage is visible.

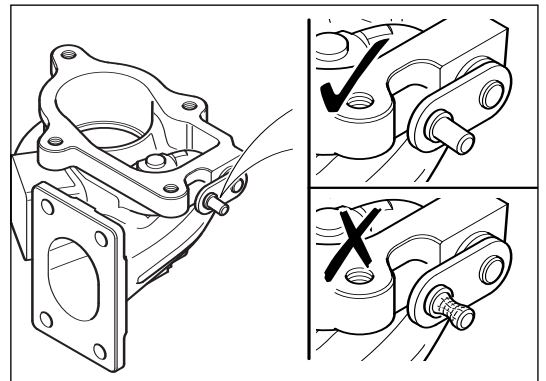
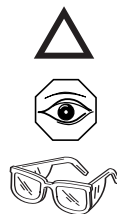

Caution

If the wastegate valve mechanism shows any fault, it must be replaced. Using damaged turbine housings will lead to inferior performance of the turbocharger, and risk of irreparable damage to both turbocharger and engine.

Radial cracks can occur around the valve seat when the turbocharger has been abused overheated. Use a torch to inspect for cracks when visibility is restricted.

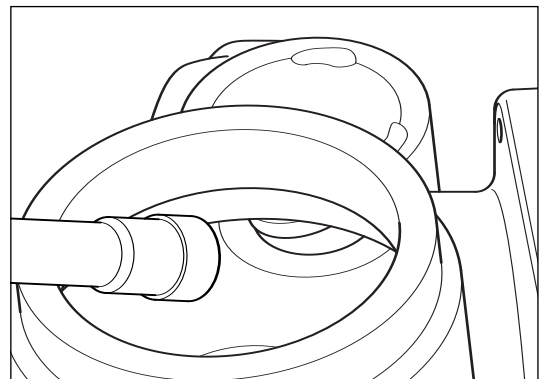



Wastegate Actuator

Inspect the actuator rod end bore which locates on the lever arm pin for elongation. Ovalisation must not exceed 0.50 mm (0.020 in).

Caution

If the actuator shows any fault, it must be replaced.

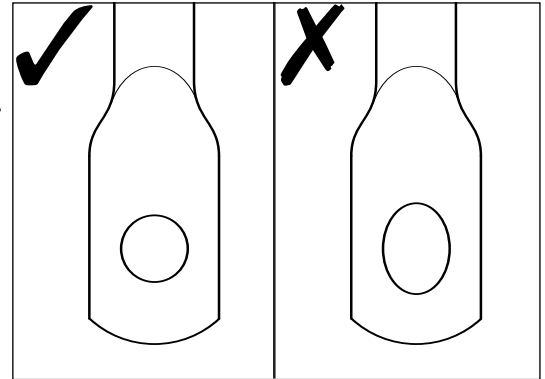

Bearing Housing

Inspect journal bearing bores for wear and score marks. Replace bearing housing (4) if a bore diameter exceeds a maximum of 13.006 mm (0.512 in) or when bore scratching is severe.

Check that the oil cavity is free from carbon and any entrained debris that may be the result of a failure.

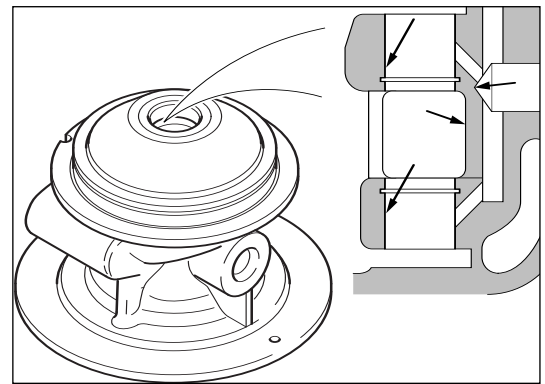

Check oil seal plate, retaining ring groove is clean and has no debris.

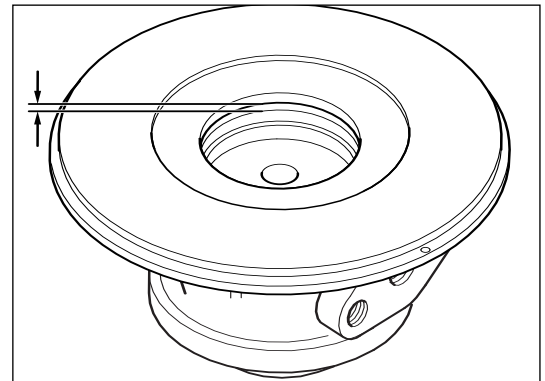

Small Components

Oil Slinger

Inspect and replace oil slinger (31) if the piston ring groove walls are scored, damaged or worn.

Check for signs of rubbing and scoring on the thrust surface and replace where damage is severe.

If the ring faces show any signs of wear replace the split ring seal, compressor (16).

If the free gap of the ring is less than 2.0 mm (0.08 in) replace the split ring seal, compressor (16) *.

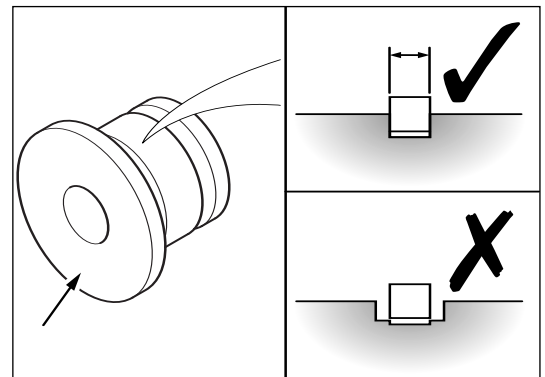



Heat Shield

Check and replace if the heat shield (38) is distorted or if signs of rubbing or cracking are visible.

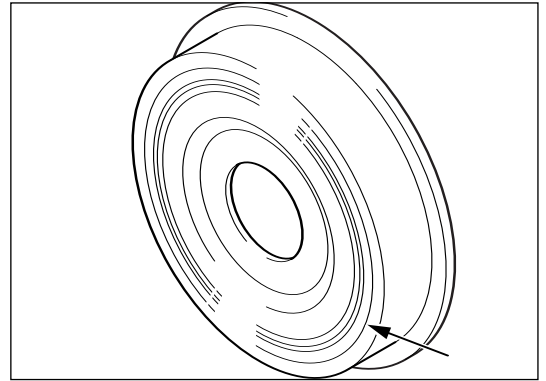

Thrust Collar

Check and replace if thrust collar (36) is scored on thrust face or if any cracks are visible.

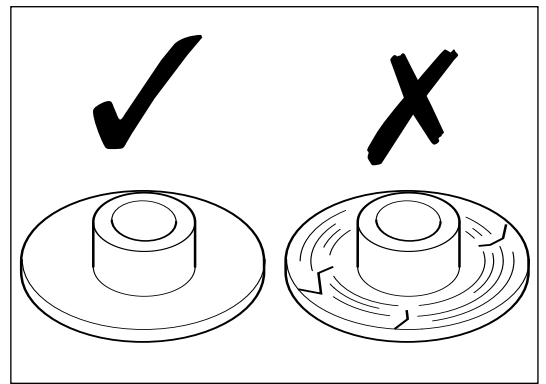

Reassembly



Core Balance

Caution This turbocharger was manufactured using a high speed core balance process. It must be re-balanced on reassembly using a vibration sorting rig (VSR).

Caution Any attempt to balance the rotor using scribe marks could lead to turbocharger and engine failure. Do not scribe mark any rotor component.

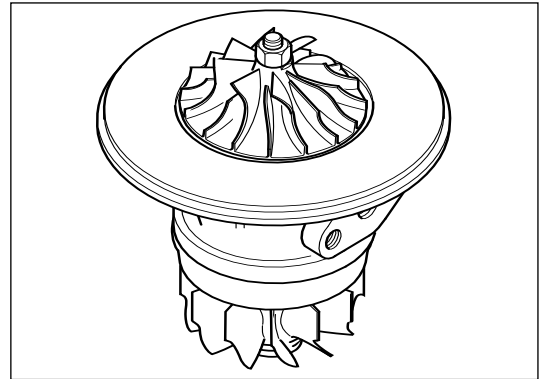

Small high speed turbochargers require a new standard of balancing process using a proprietary vibration sorting rig (VSR). As the results of vibration based tests are rig specific, the balance limits shown in Holset's [Service Data Sheets](#) are advisory only. Refer to repair agent to warrant durability, noise and vibration level of the specific balancing process used.

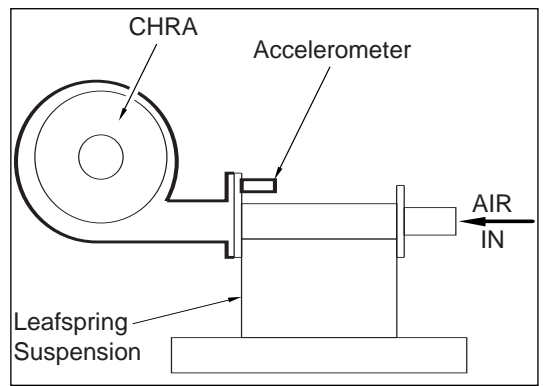

Turbocharger Reassembly

Warning Always wear safety glasses when refitting sealing and retaining rings.

Install new split ring seal, turbine (13) * to assembly, turbine wheel.

Lightly oil journal bearing, turbine (11) * and insert into position against inboard retaining ring, bearing (64).

Note Proprietary retaining rings, bearing may still be fitted following cleaning and inspection. Refer to [Disassembly](#) for removal/fitting. They can be replaced by an equivalent circlip.

Caution When fitting circlips always ensure the bevelled edge is facing the journal bearing. Premature failure will result from incorrect orientation.

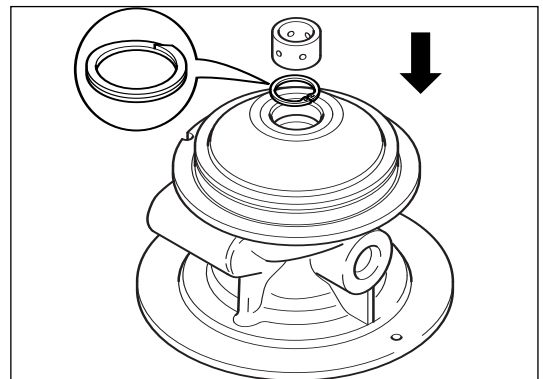
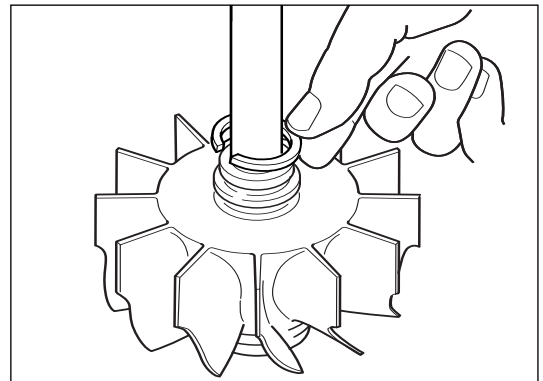



Place bearing housing compressor face on a clean surface.

Place heat shield (38) on shaft and insert assembly, turbine wheel (6) into assembled turbine end journal bearing. Ensure wheel spins freely by hand rotation.

Warning

Always wear safety glasses when refitting retaining rings.

Caution

When fitting circlips always ensure the bevelled edge is facing the journal bearing. Premature failure will result from incorrect orientation.

Caution

The turbine wheel blades can be easily damaged during insertion into the turbine housing.

Turn over the bearing housing and position in turbine housing. Ensure that the assembly, turbine wheel is loosely retained by hand until it is properly held by the turbine housing. Lightly oil journal bearing, compressor (11) * and locate into position on assembly, turbine wheel against its inboard retaining ring (64).

Insert thrust collar (36)

Install thrust bearing (12) on to its location pins. Lightly oil the thrust face.

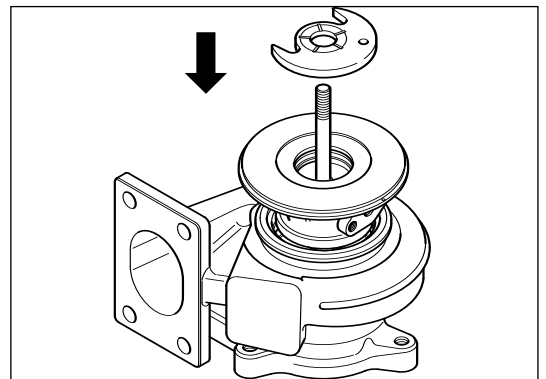
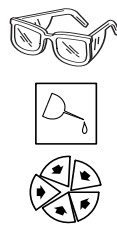
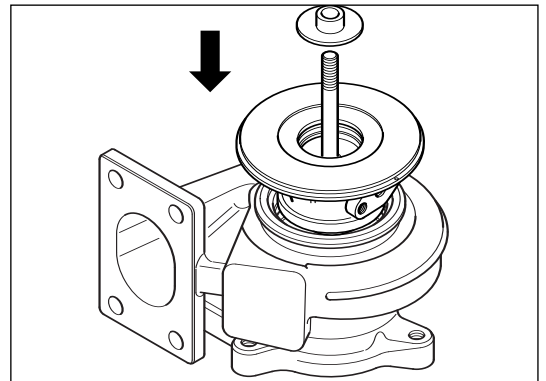
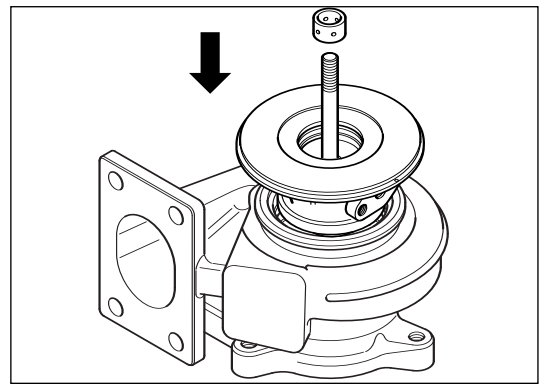
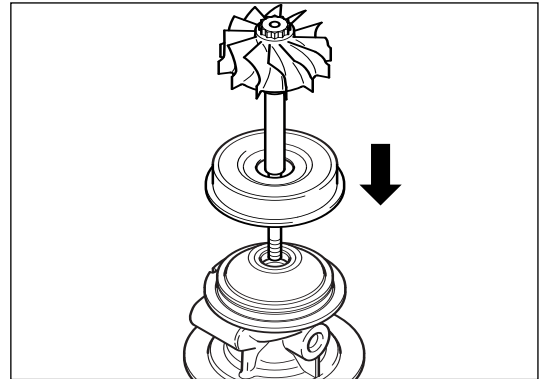



Warning 

Always wear safety glasses when refitting sealing rings.

Loosely assemble oil baffle (33) to oil slinger (31).

Complete sub-assembly by fitting new split ring seal, turbine (13) * to oil slinger/ oil baffle loose assembly.

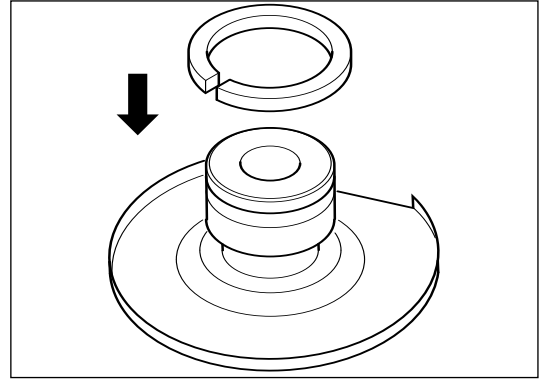

Insert oil slinger assembly into oil seal plate (43).

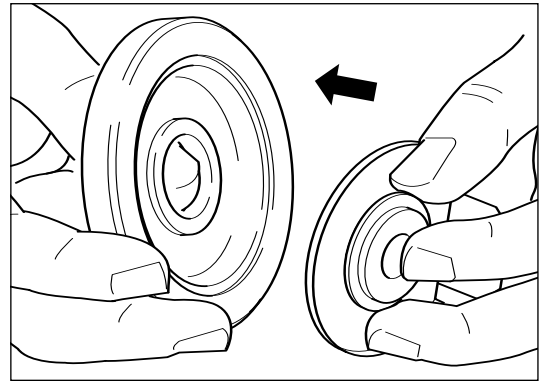

Lightly oil the o-ring seal, bearing housing (32) and insert.

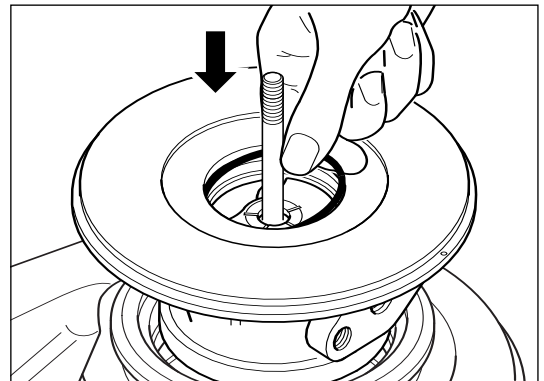
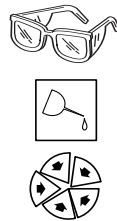

The oil seal plate assembly will require finger pressure to overcome o-ring pre-compression and achieve its axial location.

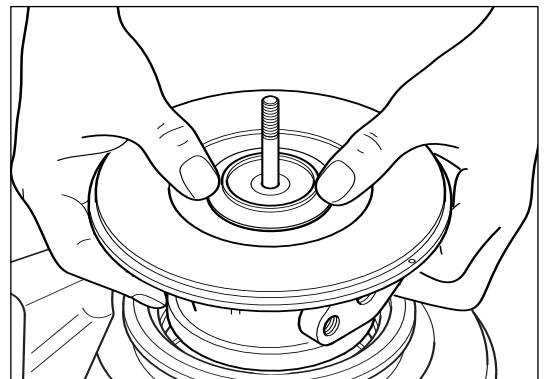



Warning

Always wear safety glasses when refitting retaining rings.

Use suitable circlip pliers to install the retaining ring, insert (66).

Caution

The retaining ring must be fitted with the chamfered face upwards away from the oil seal plate.

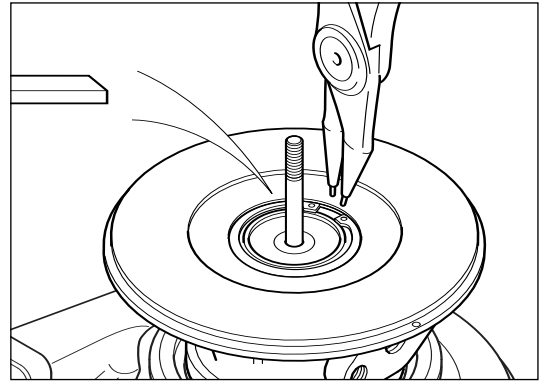

Tap ends of retaining ring (66) lightly with hammer and drift to ensure that the retaining ring is properly located into its groove in the bearing housing.

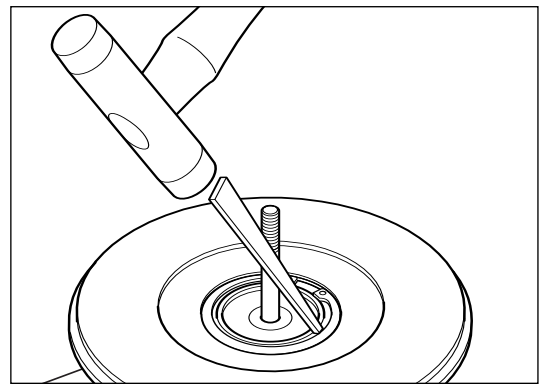

Remove partly built core from turbine housing and clamp turbine wheel in 12mm 12 point socket located in suitable jig.

Ensure that back face of compressor wheel (7) is clean and free from damage. Install on to the shaft.

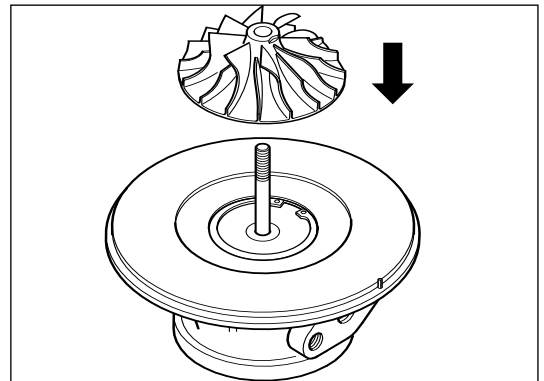
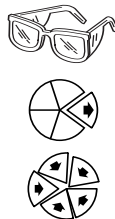

Brush the locknut face with a molycote anti-seize compound to avoid loss of clamp load during torque tightening.

Caution

Always fit a new locknut, compressor wheel to facilitate re-balancing on vibration sorting rig (VSR).

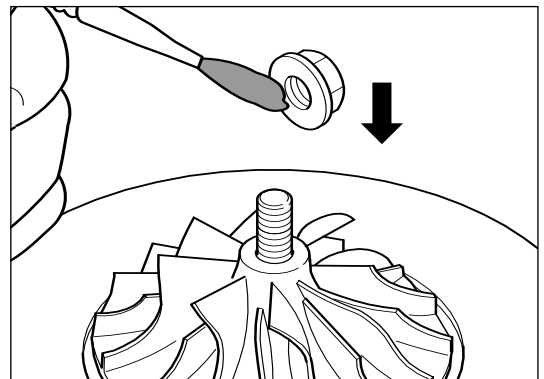



M7 LH (10 mm)

Install the new locknut, compressor wheel (61) and tighten in two stages to the values shown in the [Service Data Sheet](#).

Note

Left hand thread.

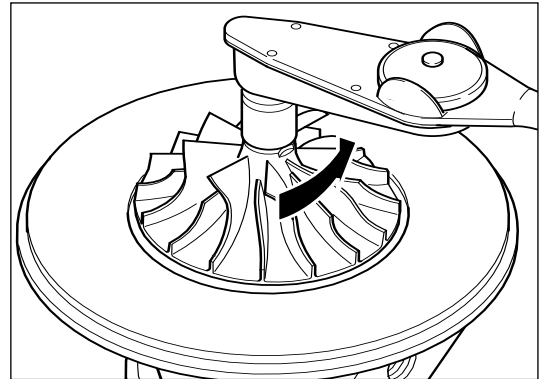
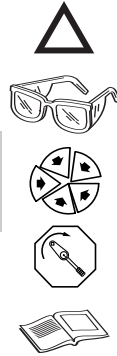

Place turbine housing (5) on a clean surface. Place v-band (28) loosely into position on the turbine housing. Carefully slide CHRA (2) assembly into the turbine housing. Use alignment marks to locate CHRA assembly onto the dowel pin located in the turbine housing.

Caution

The compressor wheel blades can be easily damaged when the CHRA is installed.

Caution

Be careful not to bend the location pin during assembly.

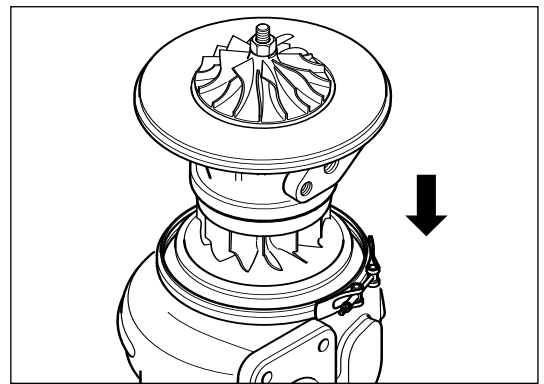

M6 (10 mm)

Apply molycot anti-seize compound to threads of locknut, v-band (62) and tighten to the value specified in the [Service Data Sheet](#).

Ensure rotor assembly freely rotates.

Caution

Be careful not to bend the location pin during assembly.

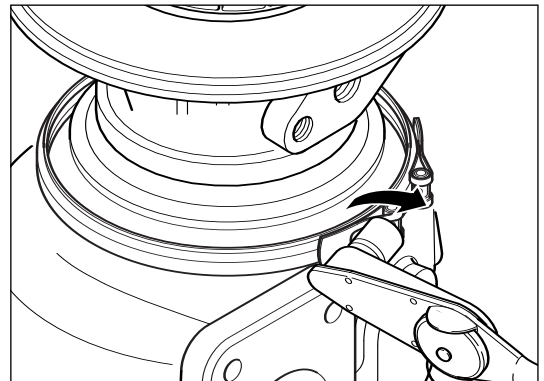

Check thrust clearance using a dial gauge. Ensure clearance is within MIN/MAX values shown on [Service Data Sheet](#).

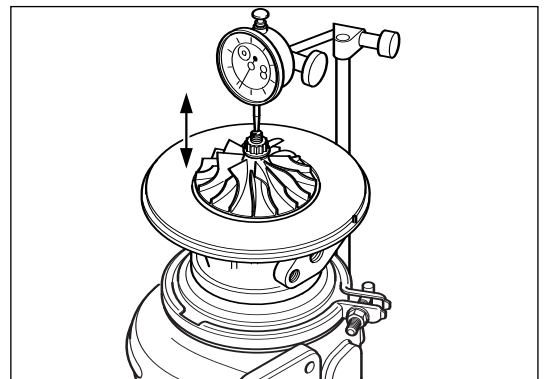



Check compressor end radial movement using a dial gauge. Ensure clearance lies within MIN/MAX TIR (Total Indicator Reading) values shown on [Service Data Sheet](#).

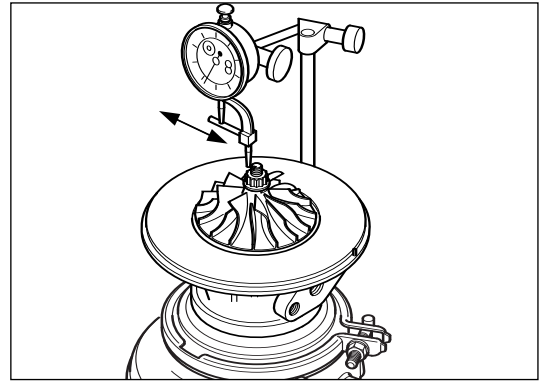

Remove locknut, v-band clamp and carefully extract core for balancing on vibration sorting rig (VSR) to the advisory limits shown in the [Service Data Sheet](#).

Caution

Be careful not to bend the location pin during disassembly and reassembly.

Note

Refer to [Core Balance](#) for a description of the VSR balancing process.

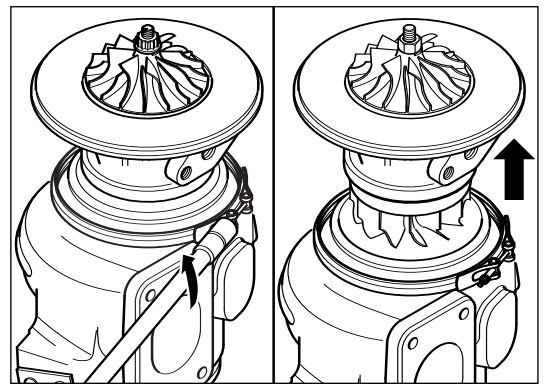
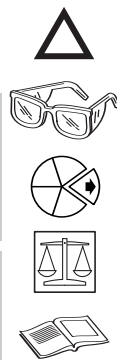

M6 (10 mm)

Relocate balanced CHRA (2) into turbine housing (8) using alignment marks to locate assembly on to roll pin fixed in turbine housing. Apply molycote anti-seize compound to the locknut, v-band (62). Tighten locknut to the torque shown in the [Service Data Sheet](#).

Caution

The turbine wheel blades can be easily damaged when the CHRA is installed.

Using a soft faced hammer, tap the v-band clamp three or four times at equally spaced distances around its circumference. Re-tighten locknut, v-band (62) to the torque shown in the [Service Data Sheet](#).

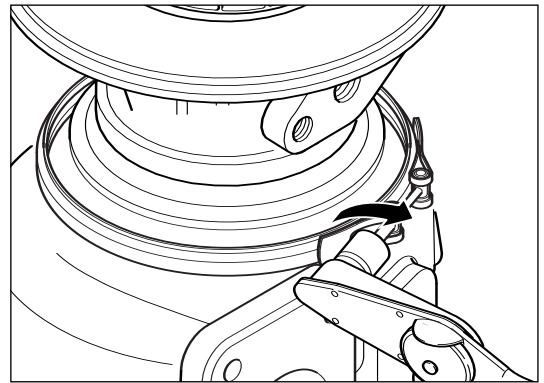

Lightly oil o-ring seal, compressor housing (41) and insert.

Caution

Always fit a new seal on reassembly.

Grease o-ring seal lightly to ensure it stays in position during reassembly.

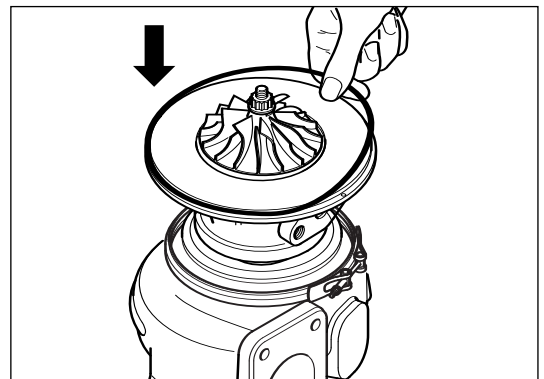



Place retaining ring, compressor housing (91) around bearing housing. Carefully locate the compressor housing over the compressor wheel and locate on the bearing housing spigot.

Caution

The compressor wheel blades can be easily damaged when the compressor housing is installed.

Caution

Do not bend location pin fitted in compressor housing during assembly.

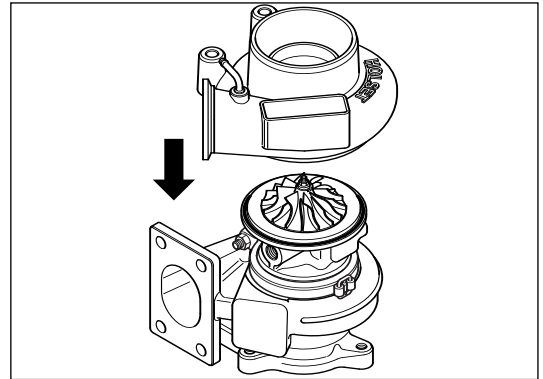

Warning

Always wear safety glasses when refitting retaining rings.

Carefully turn the loose assembly on to the compressor housing inlet face.

Locate retaining ring over CHRA. Using suitable circlip pliers, fit the retaining ring.

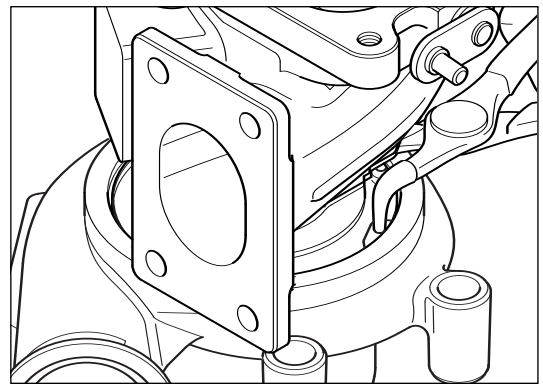

Tap ends of retaining ring lightly with hammer and drift to ensure that the retaining ring is properly located into its groove in the bearing housing.

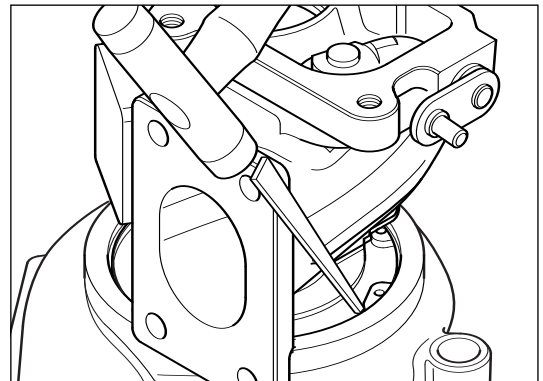

Pre-set Wastegate Actuator Reassembly

Caution

Contact your local approved dealer for the correct replacement actuator kit (74). It is important to quote the correct turbocharger assembly number, serial number and type to ensure the supply of the correct pre-set actuator.

Note

When refitting existing actuator the end link (76) will be locked in the correct setting.

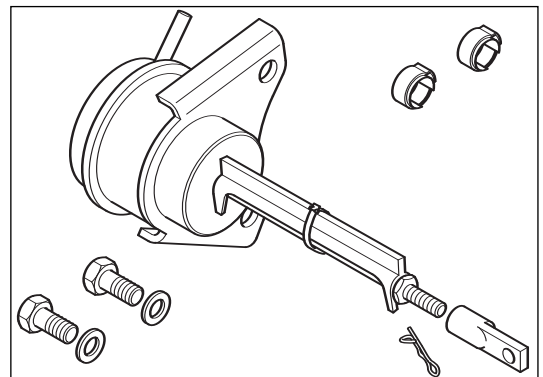



Thread new end link (76) several turns on to the shaft of the new pre-set actuator assembly (73).

Hold the actuator assembly with the spine of the spacer piece upright. Rotate the valve mechanism lever arm to close the wastegate valve (pushed towards the compressor end). Fit end link (76) over the lever arm pin.

Attempt to slide the actuator bracket over its retaining lugs. If the actuator bracket fouls on the lugs or there is significant clearance between bracket and lugs, actuator rod length requires adjustment.

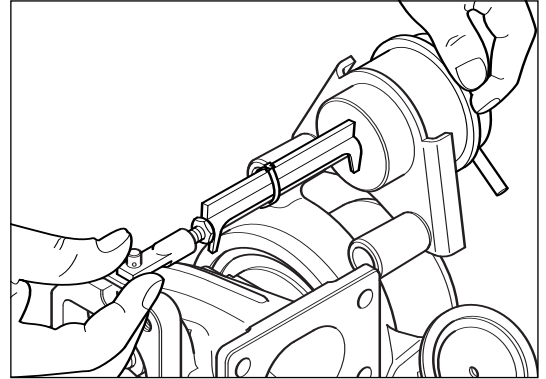

Note

Do not fit actuator screws at this stage.

Caution

Do not apply force to push actuator on to its mounting lugs.

The rod length setting is correct if, by rotating end link clockwise by a half turn, the actuator bracket fouls on the lugs.

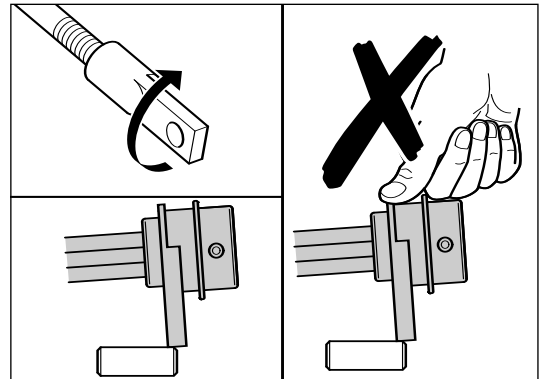

M8 (12 mm)

Fit actuator mounting fasteners with washers and torque tighten to the value shown in the [Service Data Sheet](#).

Warning

Always wear safety glasses when fitting wastegate actuator.

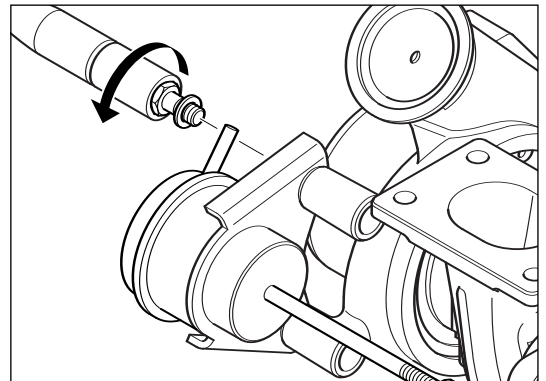

Fit new spring clip to retain rod end on pin.

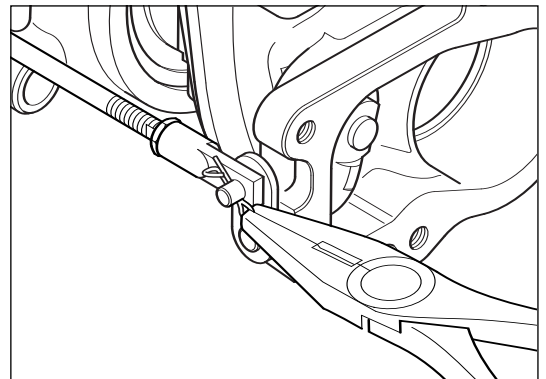



(10 mm)

Loosen spacer piece by turning jam-nut anti-clockwise (counter-clockwise). Remove and discard tie wrap and spacer piece.

Continue turning jam-nut in the same direction, and torque tighten against end link to value shown in [Service Data Sheet](#).

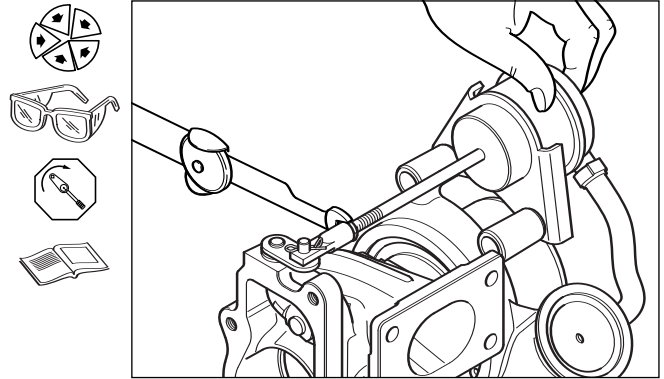

New pre-set actuator kits (74) may be supplied with a tamper resistant breakoff nut (143) instead of a jam nut (128).

To install a tamper resistant actuator:

1. Slacken the shear nut from the spacer spine
2. Continue to turn the nut until it contacts the pre-set end link
3. Continue tightening until the hex flats break off leaving only the cone section in tight contact with the end link.

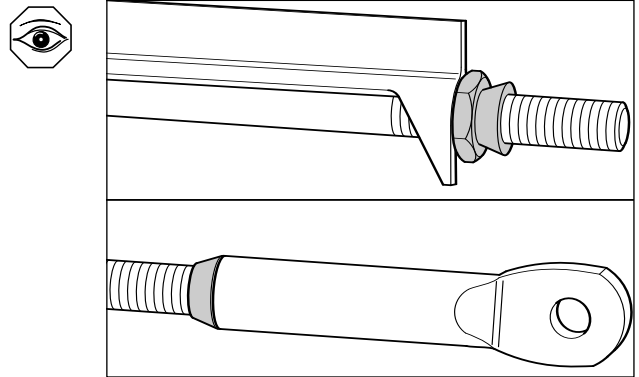

Ensure rotor assembly rotates freely.

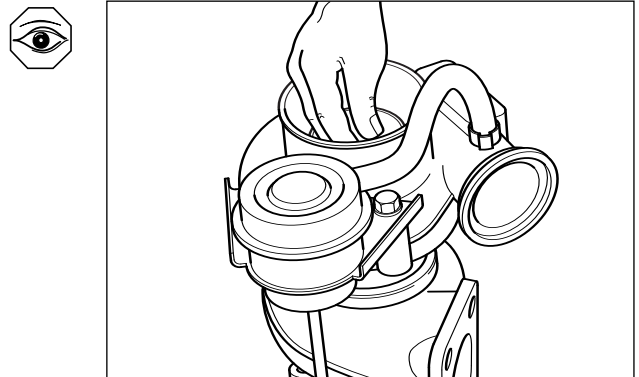



Holset HE221W

Service Repair Manual

Cummins Turbo Technologies Ltd.
Aftermarket Division
Croset Avenue
Huddersfield
West Yorkshire
HD1 6SE
www.holsetaftermarket.com