

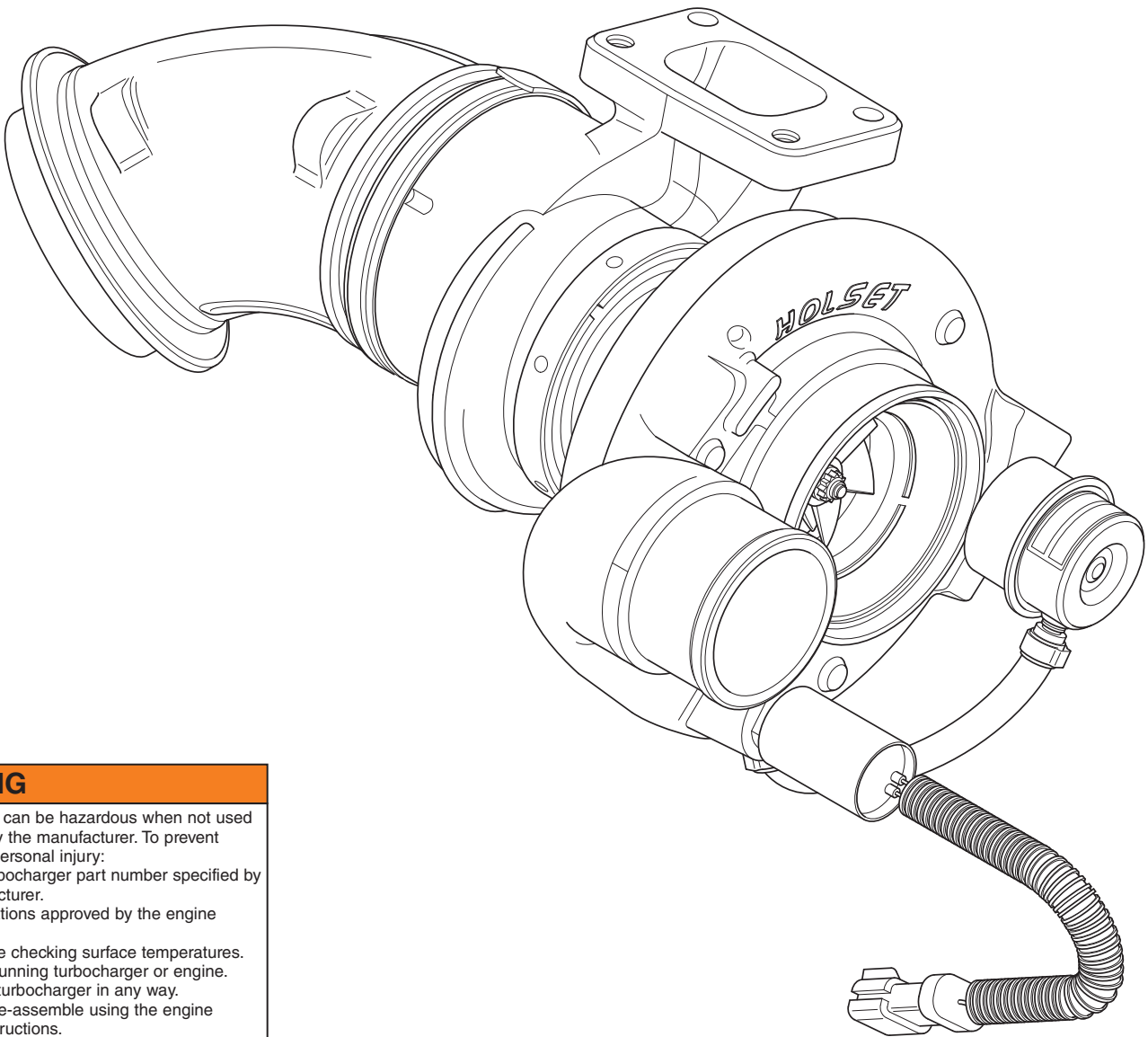

Holset HE351CW

Service Repair Manual



WARNING

-  Turbochargers can be hazardous when not used as specified by the manufacturer. To prevent damage and personal injury:
- Always use the turbocharger part number specified by the engine manufacturer.
 - Use only in applications approved by the engine manufacturer.
 - Do not touch before checking surface temperatures.
 - Do not work on a running turbocharger or engine.
 - Do not modify the turbocharger in any way.
 - Disassemble and re-assemble using the engine manufacturer's instructions.
 - Use only approved spare parts.
- For advice on the safe use of turbochargers contact www.holset.com**

Foreword

This publication was written to assist with turbocharger installation, maintenance and overhaul. It is not a warranty of any kind express or implied.

The specifications and procedures in this manual are based on information in effect at the time of publication. Holset Service reserves the right to make any changes at any time without obligation. If differences are found between your turbocharger and the information in this manual, contact your local Holset approved agent.

The latest technology and the highest quality standards are used in the manufacture of Holset Turbochargers. When replacement parts are needed, we recommend using only genuine Holset parts.

Table of Contents

1: Introduction

About the Manual	1:1
How to Use the Manual.	1:1
How to Order Holset Original Parts.	1:1
Description and Operation of Turbocharger	1:2
<i>General Information</i>	<i>1:2</i>
<i>Introduction to Wastegate Turbochargers.</i>	<i>1:2</i>
<i>Notes, Cautions and Warnings.</i>	<i>1:3</i>
Installation Data.	1:4
Installation Checklist	1:5
Symbols	1:6

2: Component Identification

Turbocharger Identification	2:1
<i>Dataplate and CHRA (Core) of Turbocharger.</i>	<i>2:1</i>
<i>Installation Options</i>	<i>2:2</i>
Exploded Views	2:3
Component List.	2:4
Purchasable Service Tools.	2:5

3: Troubleshooting and Diagnosis

Fault Finding Chart	3:1
--------------------------------------	------------

4: Component Testing and Replacement

Service Tools	4:1
On Engine Checks	4:2
Discharge Pipe Removal and Refitting	4:6
Bearing Clearance.	4:7
Wastegate Actuation Checks	4:8
Wastegate Actuator Checks.	4:9
Actuator Removal.	4:10
Wastegate Mechanism Check.	4:11
Wastegate Actuator Replacement	4:13
Command Valve Checks	4:16
Command Valve Removal and Refitting	4:16
Command Valve Cleaning	4:17

6: Service Data Sheets

HE Range Service Data Sheets	6:1
--	-----

About the Manual

The procedures in this manual were developed to instruct in the correct overhaul of the designated Holset turbochargers for optimum performance and minimum maintenance operation.

How to Use the Manual

The manual is split into sections designed to provide service information in a logical sequence. The manual contains links to help the user navigate between relevant sections. Users who are unfamiliar with navigating in PDF documents are referred to Navigating in PDF documents in the **Adobe® Acrobat® Reader™** help file.



Contents is an interactive page with links to all the sections. It can be accessed from any page in the manual by clicking this icon.

Section 1 defines the layout of the manual, introduces the reader to the operation of the turbocharger and presents important installation guidelines.

Sections 2, 3 and 4 concentrate on Turbocharger Component Identification, Troubleshooting and Diagnosis, Component Testing and Replacement.

Section 5 identifies the Service and Overhaul procedures to be followed in the unlikely event of a major turbocharger malfunction. **(This section is not available for the HE351CW turbocharger range at the present time)**

Section 6 quantifies build data to ensure the turbocharger will continue to operate to Holset Service standard on completion of overhaul.

Manual sections 1 to 5 where applicable, appear as a **self extracting** compressed file which is organised according to the steps needed to most easily and correctly maintain the operation of the turbocharger. Users are required to download this file to hard disk. Section 6 has its own file identity and resides at www.holset.co.uk. so that Holset can update the Service Data as changes occur. The links between manual and service data are active only when the user is connected to the Internet.

Chapter 6 has an expiry date to encourage users to discard outdated saved or printed versions and always access the latest information available at www.holset.co.uk.



When using the manual on-line this icon will link to Holset's website to help find your nearest agent for advice and how to order Holset original parts.

How to Order Holset Original Parts

To make sure of optimum performance, certain items must be discarded during disassembly and replaced with new for re-assembly. These items are indicated in the Service and Overhaul section with the use of a ***** symbol.

All items showing a ***** are available in a basic overhaul kit.

To get the correct parts for your turbocharger, refer to the 'component identification' section of this manual to help you find the following information:

- 1) Refer to the exploded view and component list to define the major components to be replaced.
- 2) Refer to the turbocharger's dataplate which will be found on the compressor housing or actuator to define the identifying information about your turbocharger build standard.
- 3) Contact your local Holset agent with component identification nos. and dataplate assembly no., serial no. and turbocharger type.
- 4) With this information, your local agent can provide you with the optimum kit of parts for re-assembling your turbocharger for continued long life operation.

Description and Operation of Turbocharger

General Information

A turbocharger is a mechanical device which uses the engine's exhaust gases to force more air into the engine cylinders. Hot exhaust gas energy is used to turn a turbine wheel and shaft. At the other end of the shaft is the compressor impeller (or compressor wheel), which draws in air and forces it into the engine cylinders.

Supplying increased air mass flow to the engine provides improved engine performance, lower exhaust smoke density, improved operating economy and altitude compensation. The turbocharger has proven to be one of the most beneficial devices for improving engine performance. It performs its job very well, as long as it is properly cared for.

Introduction to Wastegate Turbochargers

The need for wastegated turbochargers

The wastegate turbocharger on your vehicle's engine is of a very advanced type, which varies the effective size of its turbine in response to the driver's demands. Under all conditions of driving, the turbine wastegate is electronically controlled to change the amount of air supplied to the engine, to ensure maximum performance, lowest fuel consumption and minimum exhaust emission levels.

When rapid vehicle acceleration is required, the turbocharger will produce air for the engine more quickly than a conventional unit, reducing turbocharger lag and giving improved vehicle drivability. As the engine and turbocharger run in, and eventually start to wear, the controlled wastegate and its associated electronic control, will change its characteristic to keep to the original performance and emission levels over a wide range of ambient temperatures and altitude.

The importance of correctly servicing the wastegate actuator mechanism

A wastegate turbocharger requires accurate setting at point of manufacture. It is very important to adhere to setting limits when servicing the turbocharger, as failure to do so could result in turbocharger or engine failure.

Effects of wrong setting

Possible consequences if the actuator is set to give a boost pressure too low:

- Engine runs fuel rich
- Exhaust temperature increase
- Hydrocarbon levels increase
- High cylinder temperature risks damage to engine pistons
- Fuel consumption increase
- Smoke levels increase
- Risks of failing emissions tests

Possible consequences if the actuator is set to give a boost pressure too high:

- Engine runs fuel weak (lean)
- Excessive boost overspeeds turbocharger
- Increased cylinder pressure risks damage to engine head gasket, pistons and valves
- Nitrous oxide levels increase
- Turbocharger bearing failure and wheel fatigue problems
- Intercooler load increases causing engine to overheat, risking piston damage

Notes, Cautions and Warnings

Notes, Cautions and Warnings are used in this manual to emphasise important or critical instructions.

Note

Information which is essential to highlight.

Caution

Maintenance or Service procedures which if not strictly followed, will result in damage or destruction of the turbocharger.

Warning

Maintenance or Service procedures which if not correctly followed will result in personal injury or loss of life.

Note

Holset turbochargers can be remanufactured using recovered parts. Where it is necessary to dispose of components or whole turbochargers, an environmentally responsible process such as recycling should be used, with due regard to local laws.

Note

Holset Service receives many turbocharger returns that are no fault found. Before assuming the turbocharger is not performing to specification always refer to the engine diagnostic system, Holset's [Turbocharger Diagnostic charts](#) and the troubleshooting diagnostic procedures of this manual.

Warning

Turbocharger surface temperature during operation can achieve 700°C (1300°F). The HY35W turbocharger weighs up to 9.1kgs (20.1 lb) and is fitted with external parts that are sensitive to manual handling.

Caution

This controlled wastegate turbocharger has been factory balanced using a proprietary high speed vibration sorting rig (VSR). On rebuild it may be balanced using the low speed core balance process but this could affect turbocharger noise level.

Service overhaul/repair must be carried out by Holset Engineering to ensure the system is correctly rebuilt. It is important to note that operating a turbocharger with a balance level greater than design limits could cause turbocharger or engine failure.

Caution

Never remove the wastegate actuator unless the actuator is to be renewed.

Never adjust the link-rod of an assembled wastegate turbocharger. The link-rods are set by the O.E. supplier to precise limits which must be adhered to maintain performance and emissions levels.

Always check that the actuator and wastegate mechanism is still in good working order, before proceeding with disassembly of your wastegate turbocharger.

Warning

Some parts are manufactured in fluoroelastomers (eg Viton) or similar that require special treatment in the case of repair and service after fire.

Installation Data

1. Holset Service receives many turbocharger returns that are no fault found. Before assuming the turbocharger is not performing to specification always refer to the engine diagnostic system and the fault finding chart of this manual to make all the recommended health checks.
2. It is important that intake and exhaust systems are fitted in accordance with the recommendations of the Equipment and Engine manufacturers. Limiting mass inertia loading is critical to turbocharger whole life operation. Maximum engine vibration input must not exceed 10g.
3. The air filter must remove particles greater than $5\mu\text{m}$ at an efficiency of 95% and be of sufficient capacity to match the air consumption of the engine. Recommended filters should always be used with a pressure drop indicator. Intake systems must be capable of withstanding depressions up to 6.9 kPa (1.0 lbf/in²).
4. Hose and clip connections of intake manifold systems must be capable of withstanding the turbocharger pressure ratio. V band clamps are preferred and must be used above 3:1 pressure ratio.
5. Exhaust systems must be capable of operating at exhaust back pressures of up to 10 kPa (1.5 lbf/in²). This limit is increased to 13.4 kPa (2.0 lbf/in²) if a catalytic converter is fitted. Exhaust brake applications are permitted to impose 450 kPa (65.3 lbf/in²) back pressure.
6. Oil should be filtered to $10\mu\text{m}$ with efficiency of 60% TWA (Time Weighted Average) / $20\mu\text{m}$ with efficiency of 85% TWA. Efficiency assessed using ISO Standard 4572/SAE J 1858.
7. The oil quality must be as specified by the engine manufacturer and will be a minimum API SE - CD (MIL - L- 2104C) specification. Improved life can be obtained by using super high performance diesel (SHPD) oils, particularly in industrial applications which use extended oil drain periods.
8. Normal oil temperature is $95\pm 5^\circ\text{C}$ ($203\pm 9^\circ\text{F}$). It should not exceed 120°C (248°F) under any operating condition.
9. Any pre-lube oil must be clean and meet the minimum CD classification.
10. The orientation of turbine housing, bearing housing and compressor cover is fixed according to application. During installation, do not attempt to rotate these components. Inclined turbocharger installation is not recommended. If an installed angle is necessary, oil inlet centreline must be ± 10 degrees from vertical and rotor centreline ± 5 degrees from horizontal.
11. Holset permits oil return pipes to decline at an overall angle of not less than 30 degrees below horizontal. All turbocharger applications require a pipe of internal diameter greater than 14 mm which has integrated connectors. To ensure oil returns into the engine under all operating conditions, the return connection into the engine sump must not be submerged and the outlet flange of the turbocharger must be 50 mm above the maximum oil level of the engine sump pan. Crankcase pressure should be limited ideally to 0.8 kPa (0.12 lbf/in²) but 1.4 kPa (0.20 lbf/in²) can be accepted by reference to Holset.
12. Oil pressure of 150 kPa (20 lbf/in²) must show at the oil inlet within 3 - 4 seconds of engine firing to prevent damage to turbocharger bearing system. A flexible supply pipe is recommended.
13. The minimum oil pressure when the engine is on load must be 210 kPa (30 lbf/in²). Maximum permissible operating pressure is 500 kPa (72 lbf/in²) although 600 kPa (88 lbf/in²) is permitted during cold start up. Under idling conditions pressure should not fall below 70 kPa (10 lbf/in²).
14. Recommended oil flows for the turbochargers are 2 litre/min at idle and 3 litre/min above maximum torque speed.
15. Do not use liquid gasket substances or thread sealant as any excess can enter the turbocharger oil system to obstruct flow.

Note:

100 kPa = 1bar (14.5037 lbf/in² = psi).

Installation Checklist

1. Always understand why the original turbocharger needs replacing before fitting another unit.
2. Check the turbocharger dataplate to ensure the Part No. is correct for the engine/application.
3. Check the engine exhaust, intake and aftercooler systems are clean and without obstruction i.e. free from oil, gasket pieces, dust/dirt/carbon or foreign objects.
4. Replace the oil and air filters using replacement parts specified by the equipment manufacturer.
5. Change the engine oil using the type specified by the engine manufacturer.
6. Check that the turbocharger oil inlet and drain pipes and connectors are clean, free from obstruction and will not leak under pressure. Before re-installing flexible pipes always ensure any burnt-on lacquer or other adhered material is removed from internal bores. If in doubt, always fit new pipes.
7. Check that the coolant pipes of water cooled bearing housing applications and connectors are clean, free from obstruction and will not leak under pressure.
8. To pre-lube the turbocharger bearings, pour some clean engine oil into the oil inlet and rotate the turbocharger rotor assembly by hand.
9. Check that the exhaust manifold flange is flat and undamaged. Mount the turbocharger on the flange and check that the turbine inlet gasket fits properly without obstructing the gas passages. Torque fasteners to engine manufacturer's recommendation.
10. Assemble the air intake and boost outlet connections. Check that the connections are secure and will not leak in use.
11. Check the exhaust system is fitted using the original mounting arrangement provided by the equipment manufacturer. Always re-fit any supports/brackets back in position to ensure the system is correctly supported.
12. Assemble the exhaust system to the turbine housing outlet. Check that the gasket/connection is secure and will not leak in use.
13. Assemble any coolant pipes and check that the connections are secure, without obstruction and will not leak in use.
14. Assemble the turbocharger oil inlet pipe and check that the connection is clean, secure and will not leak in use.
15. Connect the air pipe from the command valve to the wastegate actuator ensuring the pipe bore is clean and dry before fitment.
16. Check all clamps and fasteners are correctly tightened to the torque recommended by the equipment manufacturer.
17. Make the electrical connection between command valve and engine control module (ECM).
18. Make any ECM checks recommended by the engine manufacturer.
19. Crank the engine WITHOUT firing until engine oil flows out of the turbocharger drain flange.
20. Assemble the oil drain pipe and check that the connection is secure, without obstruction and will not leak in use.
21. Start the engine and run at idle speed for approximately 1 minute so that the oil supply system is fully operational.
22. Accelerate the engine and check that there are no leaks/obstructions of air/oil/coolant/gas under pressure.
23. Check that no hose or connection deforms under normal operation.
24. Before switching off the engine, leave it running at idle speed for at least 1 minute to cool the turbine.

Symbols

Symbole - Deutsch

In diesem Handbuch werden die folgenden Symbole verwendet, die wesentliche Funktionen hervorheben. Die Symbole haben folgende Bedeutung:



WARNUNG - Unterhaltungs und Wartungsverfahren müssen genau befolgt werden, da ein Nichtbeachten zu Personenschäden oder tödlichen Verletzungen führt.



ACHTUNG - Falls Unterhaltungs und Wartungsverfahren nicht genau beachtet werden, kann der Turbolader dadurch beschädigt oder zerstört werden.



AUSBAU bzw. **ZERLEGEN**.



EINBAU bzw. **ZUSAMMENBAU**.



INSPEKTION erforderlich.



Teil oder Baugruppe **REINIGEN**.



DIMENSION - oder **ZEITMESSUNG**.



Teil oder Baugruppe **ÖLEN**.



WERKZEUGGRÖSSE wird angegeben.



ANZUG auf vorgeschriebenes Drehmoment erforderlich.



Sicherstellen, daß die **AUSWUCHTMARKEN** an der Rotor-Baugruppe richtig ausgerichtet sind.



Elektrische **MESSUNG DURCHFÜHREN**.



Weitere Informationen an anderer Stelle bzw. in anderen Handbüchern.



Schutzkleidung muß immer getragen werden.



Deutet an, daß Teile schwer sein können.



Website-Verzeichnis mit Ihrem nächsten Holset-Händler.



Gehe zu Inhalt

Symbols - English

The following group of symbols have been used in this manual to help communicate the intent of the instructions. When one of the symbols appears, it conveys the meaning defined below.



WARNING - Serious personal injury or extensive property damage can result if the warning instructions are not followed.



CAUTION - Minor personal injury can result or a part, an assembly or the engine can be damaged if the caution instructions are not followed.



Indicates a **REMOVAL** or **DISASSEMBLY** step.



Indicates an **INSTALLATION** or **ASSEMBLY** step.



INSPECTION is required.



CLEAN the part or assembly.



PERFORM a mechanical or time **MEASUREMENT**.



LUBRICATE the part or assembly.



Indicates that a **WRENCH** or **TOOL SIZE** will be given.



TIGHTEN to a specific torque.



Ensure that the **BALANCE MARKS** on the rotor assembly are in alignment



PERFORM an electrical **MEASUREMENT**.



Refer to another location in this manual or another publication for additional information.



Please wear protective clothing at all times.



Indicates components may be heavy.



Website access to find your nearest Holset Agent.



Go to contents

Simbolos - Español

Los simbolos siguientes son usados en este manual para clarificar el proceso de las instrucciones. Cuando aparece uno de estos simbolos, su significado se especifica en la parte inferior.



ADVERTENCIA – Procedimientos de Mantenimiento o Servicio que al no seguirse resultarán en daños personales o pérdida de vida.



ATENCION – Procedimientos de Mantenimiento o Servicio que al no seguirse al pie de la letra, resultarán en el daño o la destrucción del turbosobrealimentador.



Indica un paso de **REMOCION o DESMONTAJE**.



Indica un paso de **INSTALACION o MONTAJE**.



Se requiere **INSPECCION**.



LIMPIESE la pieza o el montaje.



Ejecutese una **MEDICION** mecánica o del tiempo.



LUBRIQUESE la pieza o el montaje.



Indica que se dar: una **LLAVE DE TUERCAS** o el **TAMAÑO DE HERRAMIENTA**.



APRIETESE hasta un par torsor específico.



Ceriórese de que estén alineadas las marcas de balance en el rotor.



EJECUTESE una **MEDICION** eléctrica.



Para información adicional refiérase a otro emplazamiento de este manual o a otra publicación anterior.



Favor de siempre llevar ropa protectora.



Indica que los componentes pueden ser pesados.



Acceso a Sitio Web para localizar su agente Holset más cercano.



Ir a la tabla de materias

Symboles - Français

Les symboles suivants sont utilisés dans ce manuel pour aider à communiquer le but des instructions. Quand l'un de ces symboles apparaît, il évoque le sens défini ci-dessous:



ATTENTION DANGER - Procédures de maintenance ou d'entretien qui, si elles ne pas observées correctement, auront pour résultat des lésions corporelles ou un décès.



MISE EN GARDE - Procédures de maintenance ou d'entretien qui, si elles ne sont pas observées strictement, auront pour résultat de causer des dégâts au turbocompresseur ou de conduire à sa destruction.



Indique une opération de **DEPOSE**.



Indique une opération de **MONTAGE**.



L'INSPECTION est nécessaire.



NETTOYER la pièce ou l'ensemble.



EFFECTUER une **MESURE** mécanique ou de temps.



GRAISSER la pièce ou l'ensemble.



Indique qu'une **DIMENSION DE CLE** ou **D'OUTIL** sera donnée.



SERRER à un couple spécifique.



S'assurer que les repères d'équilibrage sur l'ensemble de rotor sont alignés.



EFFECTUER une **MEASURE** électrique.



Se reporter à un autre endroit dans ce manuel ou à une autre publication pour obtenir des information plus complètes.



Il faut toujours mettre vêtements de protection.



Indique que les composants peuvent être lourds.



Accès au site Web pour trouver l'agent Holset le plus proche.



Aller au sommaire

Símbolos - Português

Os símbolos a seguir serão utilizados neste manual para facilitar a comunicação das instruções e seu significado estão descritos abaixo.



ATENÇÃO - Os procedimentos de Manutenção ou Serviços que não forem seguidos correctamente resultarão em ferimentos pessoais ou riscos de vida.



AVISO - Os procedimentos de Manutenção ou Serviço que não forem rigorosamente seguidos resultarão em danos ou destruição do carregador turbo.



Indica um passe de **DESMONTAGEM**.



Indica um passo de **MONTAGEM**.



Requer inspeção.



LIMPE a peça ou conjunto.



Requer Medição mecânica ou de tempo.



LUBRIFIQUE a peça ou o conjunto.



Indica necessidade de **APERTO**.



TORQUEAR de acordo com o especificado.



Assegure-se de que as **MARCAS DE BALANCEAMENTO** do conjunto eixo rotor estejam alinhadas.



Requer medição **ELÉTRICA**.



Procure em outra seção deste manual ou em publicação par obter informações adicionais



Por favor, sempre utilize EPI (Equipamento de Proteção Individual)



Indica que os componentes podem estar pesados.



Visite o Website para encontrar o seu Agente Holset mais perto.



Vá para Conteúdo

Turbocharger Identification



Dataplate

Note

Dataplates may be fitted to the wastegate actuator (73) or to the compressor housing (8). The information from the dataplate must be quoted for service and parts support.

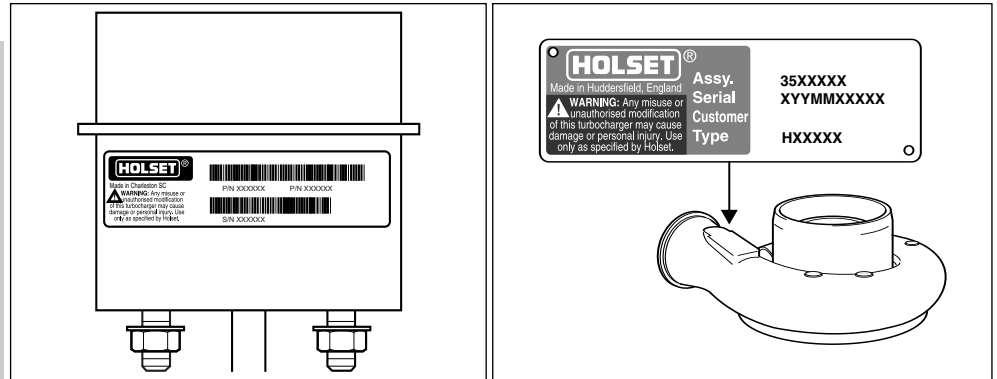

HE351CW

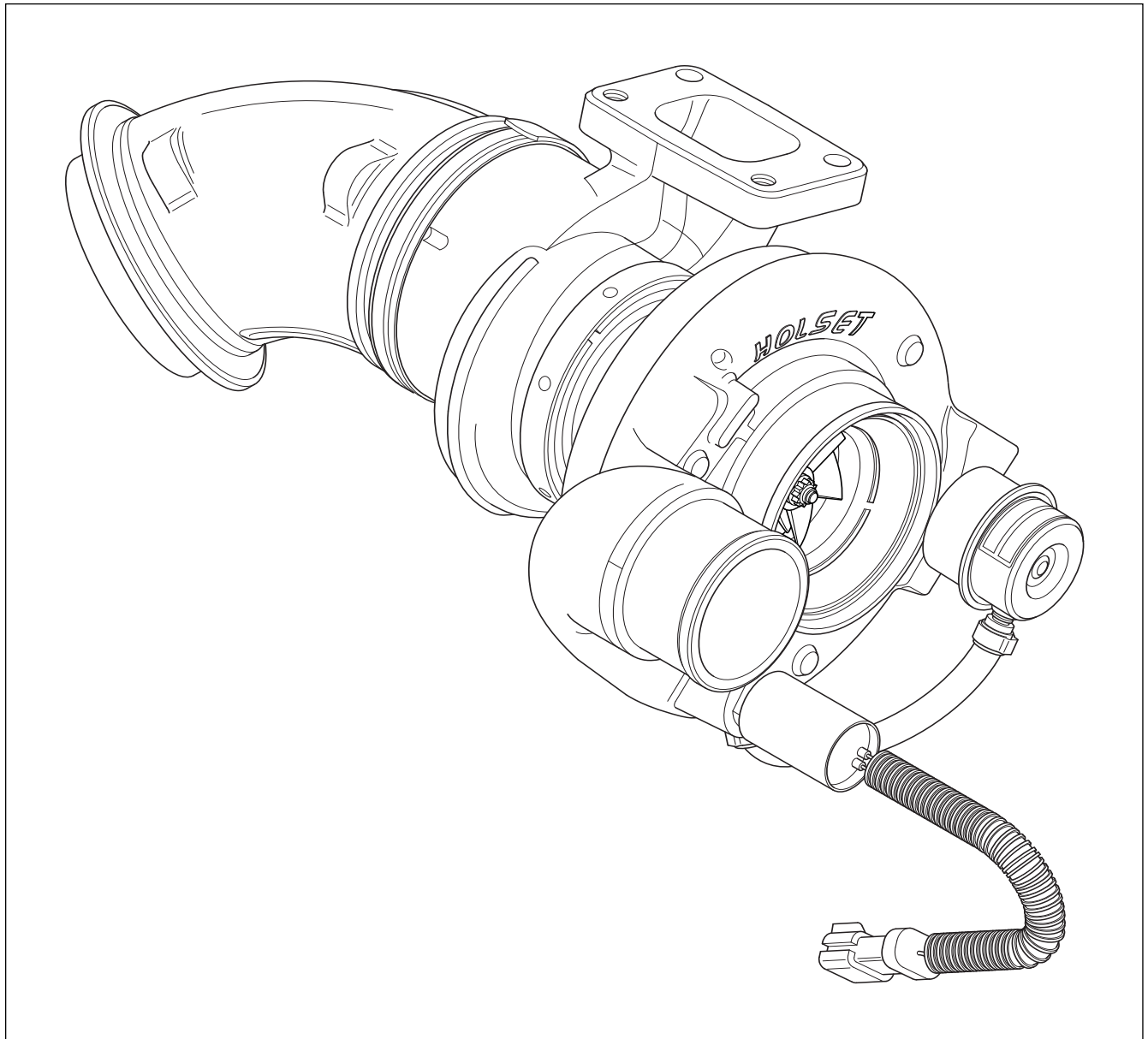



Installation Options

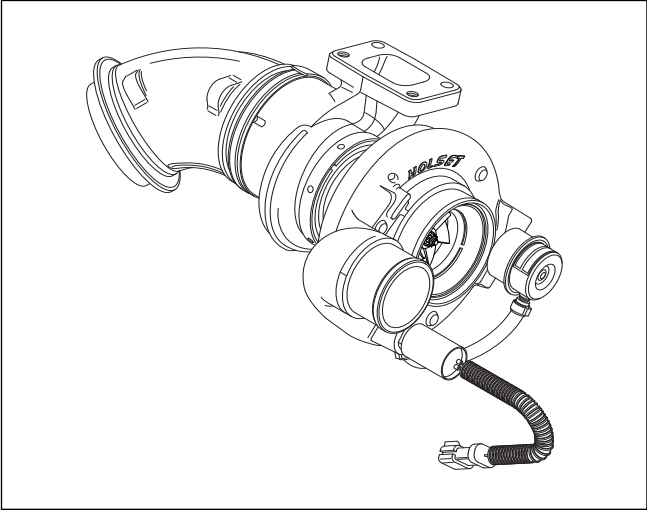

Exploded View - HE351CW

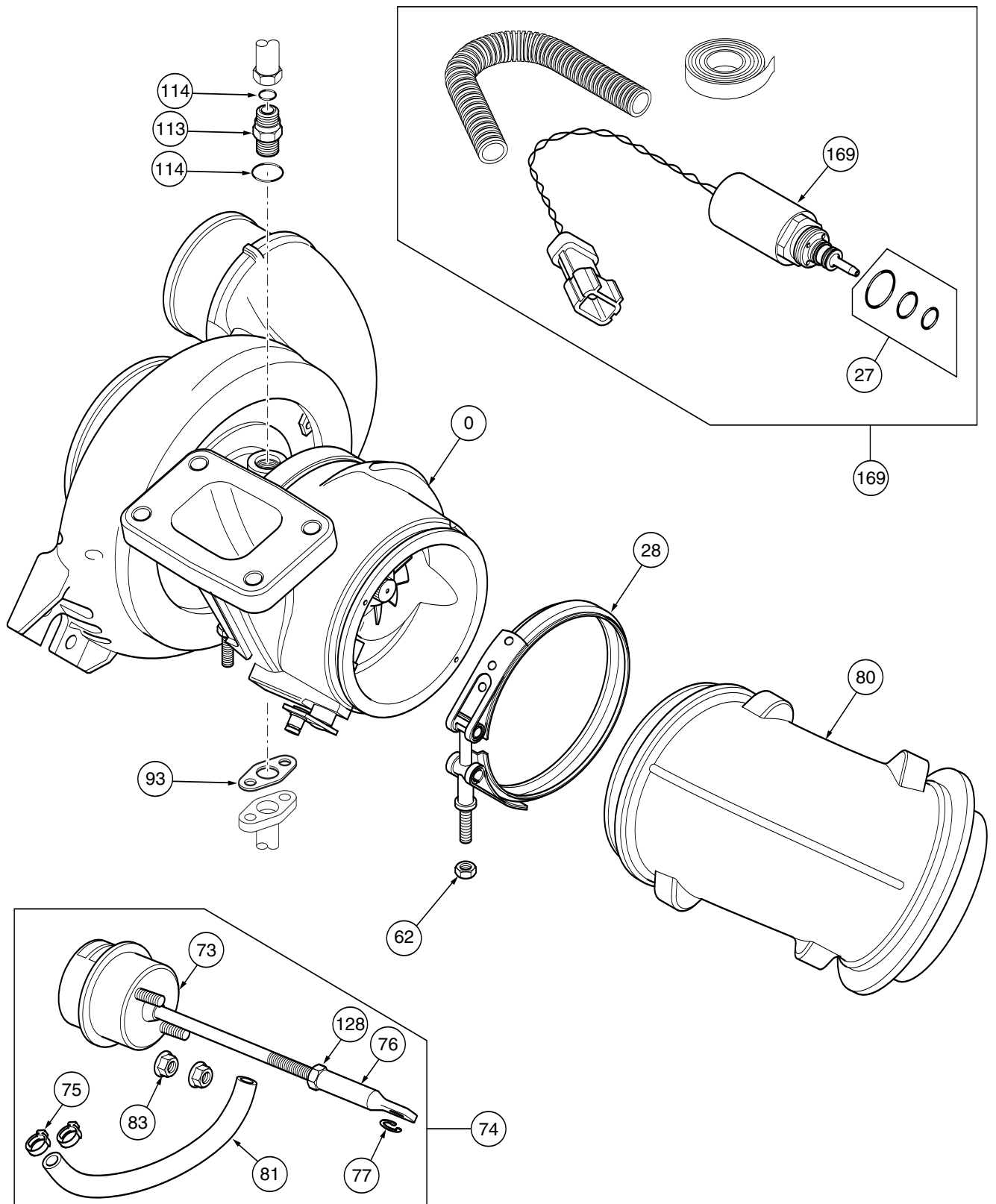

Note

Exploded views represent a generic build standard. Parts may be added or subtracted in specific applications.

Component List - HE351CW



Item No.	Description	Quantity
28	V band clamp, turbine	1
62	Locknut, V-band	1
80	Discharge pipe	1
74	Actuator kit comprising:	
73	Actuator	1
75	Hose clamp	2
76	End link assembly	1
77	End link retaining clip	1
81	Hose	1
83	Locknut, actuator	2
128	Jam nut	0/1
143	Break off nut	0/1
93	Gasket, oil outlet	1
113	Adaptor, Oil inlet	1
114	O ring seal, oil inlet	2
	Command valve kits comprising:	
	Command valve assembly comprising:	
169	Command valve	1
27	O ring seal	3
	Conduit convolute	1
	Tape	
	Command valve service kit comprising:	
27	O ring seal	3

Note

Exploded views may not contain all listed components.

Purchasable Service Tools



Service Tools

The following special tools can be purchased from your local Authorised Repair Location. The use of these tools is recommended and where necessary they are shown in the appropriate service procedure.

Part No.	Tool Description	Tool Illustration
3575186	Circlip Pliers	
4027202	Wastegate Air Feed Adapters	
4027203	Wastegate Air Feed Adapters	
4027204	E-Clip Tool	

Caution

All Service and Maintenance settings are shown in Holset's Service Data Sheet. It is essential that these settings are used. Common tools found in mechanic's tool box not included.

Fault Finding Chart - All Applications

	Engine Running Hot	Poor Transient Response	Engine Lacks Power	Black Exhaust Smoke	Blue Exhaust Smoke	High Oil Consumption	Turbocharger Noisy	Cyclic Sound from the Turbocharger	Oil Leak from Compressor Seal	Oil Leak from Turbine Seal
Dirty air cleaner Clean or replace element according to manufacturer s recommendations	●	●	●	●	●	●			●	
Restricted compressor intake duct Remove restriction or replace damaged parts as required	●	●	●	●	●	●	●	●	●	
Restricted air duct from compressor to intake manifold Remove restriction or replace damaged parts as required	●	●	●	●			●			
Restricted intake manifold Refer to engine manufacturer s manual and remove restriction	●	●	●	●			●			
Air leak in feed from air cleaner to compressor Replace seals, gaskets or tighten fasteners as required							●			
Air leak in feed from compressor to intake manifold Replace seals, gaskets or tighten fasteners as required	●	●	●	●			●			
Air leak between intake manifold and engine Refer to engine manufacturer s manual and replace gaskets or tighten fasteners as required	●	●	●	●			●			
Foreign object in exhaust manifold (from engine) Refer to engine manufacturer s manual and remove obstruction		●	●	●			●			
Restricted exhaust system Remove restriction or replace damaged parts as required	●		●	●	●	●			●	
Exhaust manifold cracked, gaskets blown or missing Refer to engine manufacturer s manual and replace gaskets or damaged parts as required		●	●	●			●			
Gas leak at turbine inlet/exhaust manifold joint Replace gasket or tighten fasteners as required		●	●	●			●			
Gas leak in ducting after turbine outlet Refer to engine manufacturer s manual and repair leak							●			
Restricted turbocharger oil drain line Remove restriction or replace damaged parts as required					●	●			●	●
Restricted engine crankcase breather Refer to engine manufacturer s manual, clear restriction					●	●			●	●
Turbocharger bearing housing sludged or coked Change engine oil and oil filter, overhaul or replace turbocharger as required	●				●	●			●	●
Fuel injection pump or fuel injectors incorrectly set Refer to engine manufacturer s manual and replace or adjust faulty components as required	●	●	●	●						
Engine valve timing incorrect Refer to engine manufacturer s manual for correct settings and adjust as required	●	●	●	●						
Worn engine piston rings or liners Refer to engine manufacturer s manual and repair as required			●		●	●			●	●
Burnt valves and/or pistons Refer to engine manufacturer s manual and repair as required	●		●	●	●	●			●	●
Excessive dirt build up on compressor wheel and/or diffuser vanes Clean in accordance with details in the appropriate Holset publication			●	●	●	●	●	●	●	●
Turbocharger damaged Find and correct cause of failure, repair or replace turbocharger as necessary	●	●	●	●	●	●	●		●	●

Fault Finding Chart - Controlled Wastegate

	Engine Lacks Power	Engine Overheats	Intermittent engine braking	Intermittent low power	Engine does not run smoothly	Low power at low engine speed	Turbocharger noisy	Poor acceleration	Reduced braking	Oil leak
Failed actuator diaphragm Replace using correct Actuator Service Kit		●							●	
Seized wastegate valve (in turbine housing) Free valve in accordance with details in the appropriate Holset publication replace complete turbine housing sub-assembly		●	●							
Leaking actuator hose Replace hose and clips		●							●	
Wastegate mechanism set incorrectly Contact your approved Holset agent for correct setting procedure	●		●	●	●					
Actuator rod not moving 1 Actuator rod not moving Check for system air leaks and change clamps and hoses as appropriate.		●							●	
2 Actuator rod not moving but OK on separate air supply Check command valve in accordance with Holset service instructions.		●							●	
3 Actuator rod not moving and not OK on separate air supply. Suspect seized wastegate valve in turbine housing. Free valve in accordance with Holset service instructions. If valve cannot be freed replace turbocharger.		●	●							
4 Failed actuator diaphragm If wastegate valve is free, command valve checked OK and there are no leaks but actuator rod does not move, replace actuator using correct Actuator Service Kit		●							●	
Actuator loose or damaged Refer to ECU diagnostics for possible fault code data. Check for damage to actuator bracket and fasteners. If mechanical installation is OK, check actuator movement. If full and free movement not confirmed, replace actuator. If partial movement with new actuator replace turbocharger	●				●	●		●		
Oil feed and return lines or adaptors leaking Check oil feed and return pipes and adaptors for leakage. Check O-ring seals and replace if necessary. Tighten adaptors and if leak persists, replace failed adaptors or pipes using Holset recommended parts..			●	●	●					
Bearing housing damaged If o ring or connector replacement does not resolve an oil leak, the bearing housing tappings may be damaged requiring replacement of the turbocharger.			●	●	●	●		●	●	
Intermittent control valve drive signal Refer to ECU diagnostics for possible fault code data. Check control valve connection to ECU. If control valve condition at either 0 V or vehicle battery voltage is incorrect or if intermittent fault persists replace control valve whilst referring to engine manual.		●	●	●	●					
No boost pressure signal (P2) If the ECU diagnoses a boost pressure signal error refer to engine manual.	●							●		
No air inlet temperature signal (T2) If the ECU diagnoses an air inlet temperature signal error refer to engine manual.	●							●		
Oil feed and return lines or adaptors leaking Check oil feed and return pipes and adaptors for leakage. Check O-ring seals and replace if necessary. Tighten adaptors and if leak persists, replace failed adaptors or pipes using Holset recommended parts.										●
Bearing housing damaged If o ring or connector replacement does not resolve an oil leak, the bearing housing tappings may be damaged requiring replacement of the turbocharger.										●

Service Tools

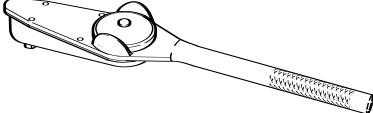
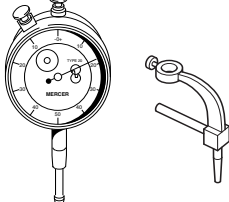
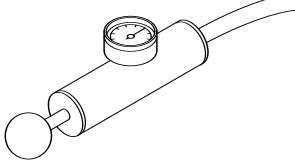
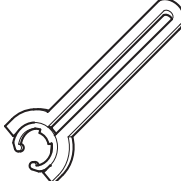

The following special tools are recommended to perform procedures in this manual. The use of these tools is shown in the appropriate procedure.

Part No.	Tool Description	Tool Illustration
	Torque Wrench	
	Dial Gauge and Dial Gauge Adapter	
	Regulated air supply	
4027204	E-Clip Tool	

Caution

All Service and Maintenance settings are shown in Holset's Service Data Sheet. It is essential that these settings are used. Common tools found in mechanic's tool box not included.

On Engine Checks



Oil Leakage

Bearing Housing M12 x 1.5 (19 mm)

Pipe Fitting 11/16-16 UN (19 mm)

Warning

The oil inlet is pressurized and no service action should be taken with the engine running.

Replacement seals and adapters should be fitted without sealant as this can contaminate the oil. Torque tighten adaptor to value shown in [Service Data Sheet](#).

It is important to avoid kinked pipes during servicing and subsequent operation.

M8 x 1.25

Warning

Outlet oil is hot and no service action should be taken with the engine running.

Replacement gaskets should be fitted without sealant as this can contaminate the oil. Torque tighten flange fasteners to value specified by engine manufacturer.

All outlet pipes should be free flowing without kinks and sharp bends and decline at an overall angle not less than 30 degrees below the horizontal.

Warning

Ensure engine start key is in off position

When oil has been found in the compressor housing it may be necessary to remove the command valve for cleaning. Refer to [Command Valve](#) for checking, removing, cleaning and refitting.

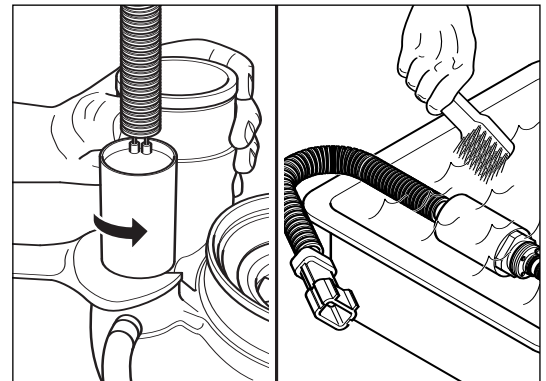
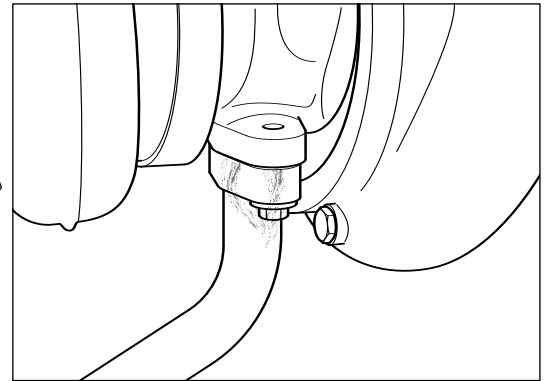
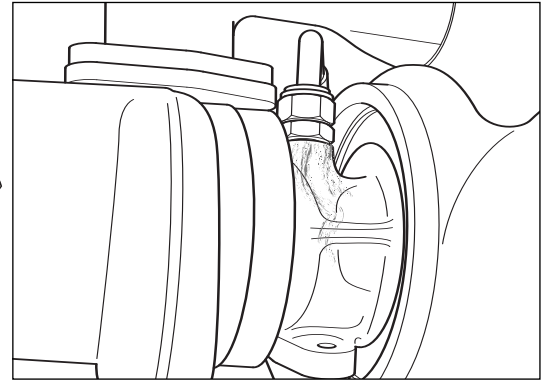



Gas Leakage

Warning

Always wear safety glasses.

Turbine housing flange leakage will cause soot formation on the flange. Check exhaust manifold to flange seal ensuring fastener torque meets engine manufacturer's recommendation.

Where leaks persist, check exhaust flange for cracks.

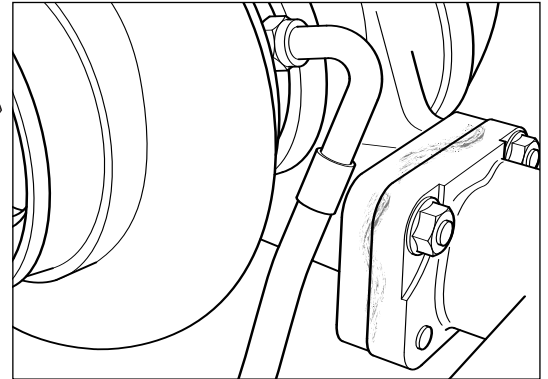
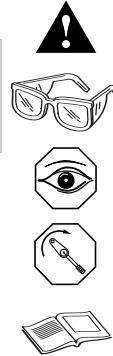

Caution

Turbine housings can exhibit cracking when subject to excessive thermal and mechanical loads.

Cracking of the turbine housing inlet flange and inlet duct generally requires turbocharger replacement. Acceptance and rejection guidelines are shown in this illustration. If an exhaust gasket is available, always ensure that any cracks lie within its sealing area.

Check turbine housing inlet flange flatness is within 0.1 mm (0.004 in) before retaining turbocharger for re-use.

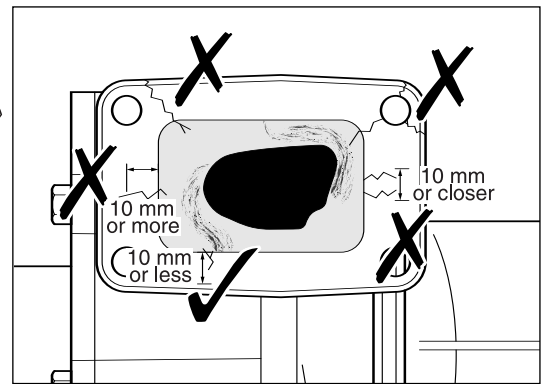

Flange Fasteners - Clearance Holes

Check fastener hole diameter is not more than 1.5 mm larger than the max. thread diameter of the fastener.

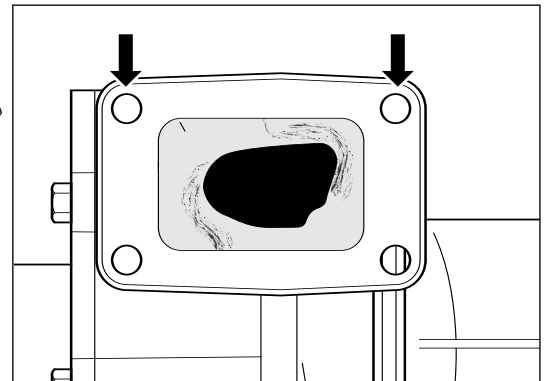

Flange Fasteners - Threaded Holes

M10 x 1.5

Check flange threaded holes with an M10 x 1.5 thread gauge.

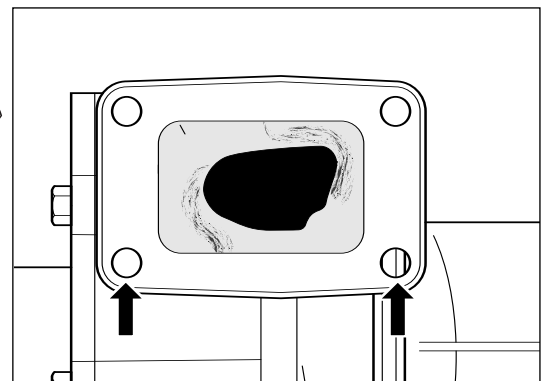



1/4 in - 28 UNF - 1B (7/16 in)

Where exhaust gas is leaking from turbine housing/ discharge pipe/ exhaust system joints, ensure v-band fastener torques meet specification. Tighten turbine housing/discharge pipe v-band locknut to torque specified in Holset's [Service Data Sheet](#). Refer to engine manufacturer for details of discharge pipe to exhaust system connection.

Warning

Always wear safety glasses.

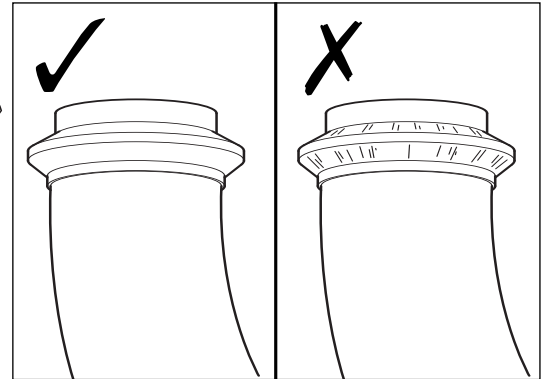
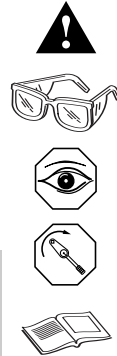

If leakage persists and where practical, disassemble exhaust system pipework. Check Marman connections for fretting damage. If sealing is compromised replace discharge pipe in accordance with [Discharge Pipe Removal and Refitting](#).

Air Leakage

(25 mm)

Check for air leaks from command valve.

Tighten command valve in accordance with [Command Valve Removal and Refitting](#). If leakage persists, remove command valve and replace o-rings using service kit comprising 3 radial o-rings (27)*.

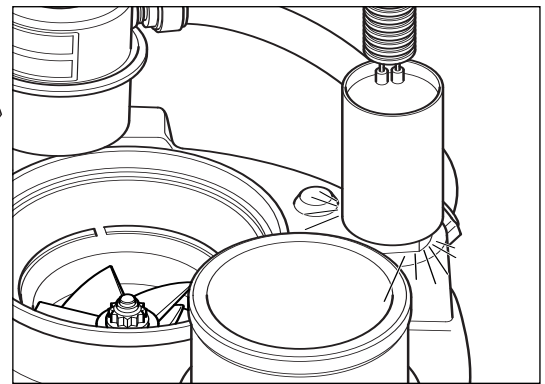
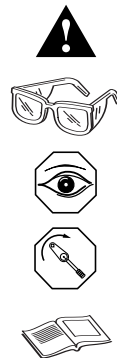

Warning

Never attempt to check for leaks using air supplied from a running engine.

If it is possible to check for wastegate actuator rod movement and air leakage on engine, follow the checking procedure described later in [Wastegate Actuator Checks](#).

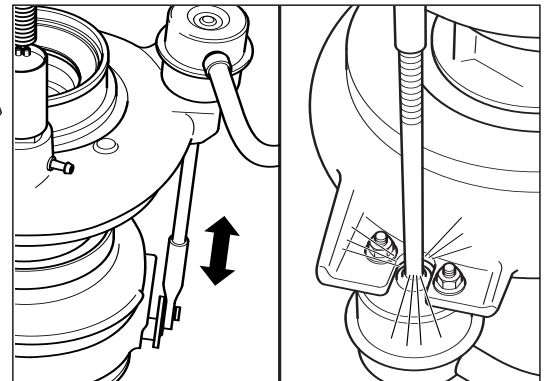

Visual Checks

Check for cracked, bent or damaged compressor wheel blades.

Replace turbocharger if damaged or bent.

Caution

Never attempt to straighten blades.

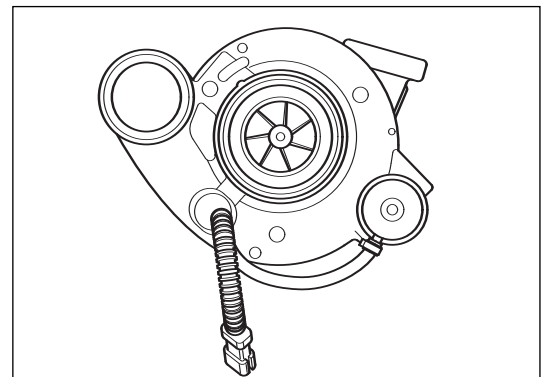



Where practical, check for cracked, bent or damaged turbine wheel blades. This will require discharge pipe removal where fitted.

Replace turbocharger if damaged or bent.

Caution 

Never attempt to straighten blades.

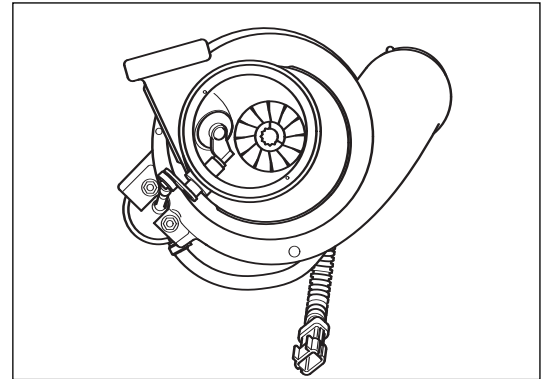

With intake system disconnected from compressor housing, it may be possible to check visually for excess bearing axial and radial clearances. If in doubt, the turbocharger must be removed from engine to check bearing clearance against recommended values shown in [Service Data Sheet](#).

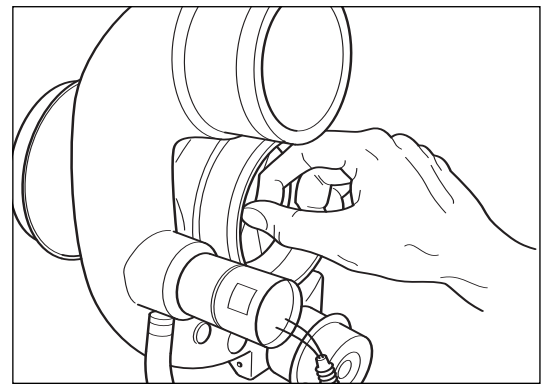

On-engine Command Valve Checks

Warning 

Ensure engine start key is in off position

Refer to [Command Valve](#) for checking, removing, cleaning and refitting.

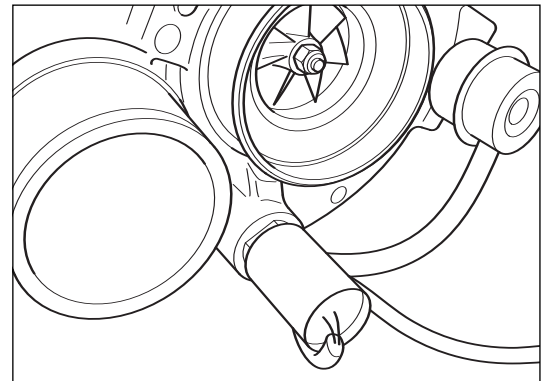



Discharge Pipe Removal and Refitting

1/4 in - 28 UNF - 1B (7/16 in A/F)

On removal of turbocharger from engine, place turbocharger compressor end on suitable workbench. Mark orientation of V-band relative to discharge pipe and turbine housing. Loosen and remove V-band nut.

Warning

Always wear safety glasses.

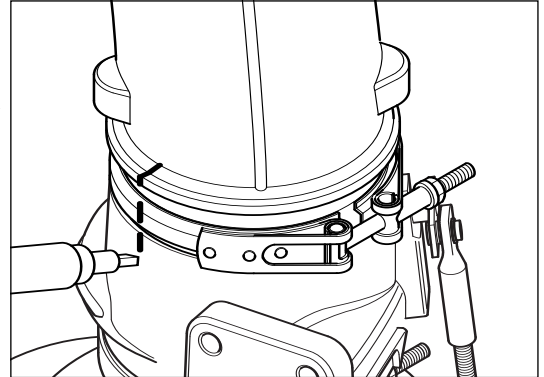

Carefully lift discharge pipe off turbine housing ensuring that the location pins are not damaged.

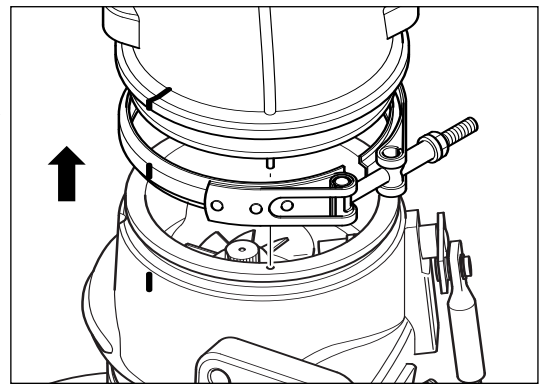

Ensure discharge pipe is fitted with 2 roll pins for location into mating holes in turbine housing.

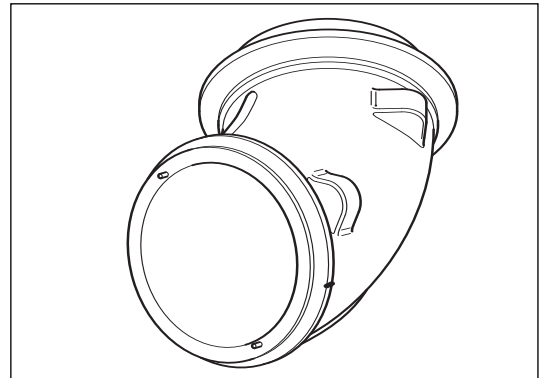

Loosely assemble V-band on to turbine housing in correct orientation. Carefully locate discharge pipe on to turbine housing using orientation marks to ensure roll pins engage correctly in location holes. Place V-band in position and torque tighten to value shown in [Service Data Sheet](#).

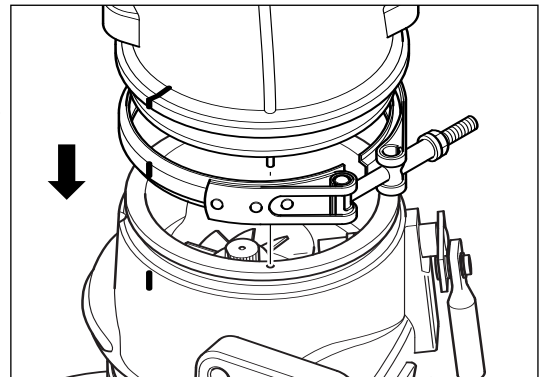
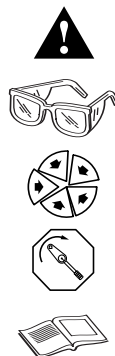

Bearing Clearance



Secure the turbine housing and check the axial clearance at compressor impeller nose using a dial gauge.

Ensure clearance is within MIN/MAX values shown on [Service Data Sheet](#).

If axial clearance does not meet specification replace the turbocharger.

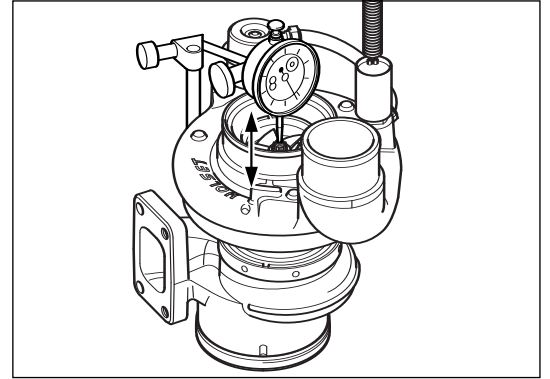

Check the radial movement at compressor impeller nose using a dial gauge.

Ensure movement is within MIN/MAX TIR (Total Indicator Reading) values shown on [Service Data Sheet](#).

If radial movement does not meet specification replace the turbocharger.

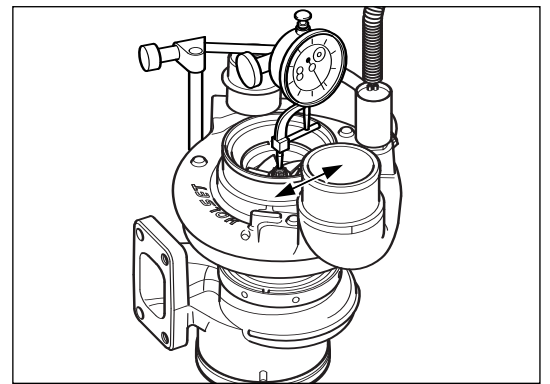

Wastegate Actuation Checks



Caution

Do not remove turbocharger from engine unless an actuator check is impractical due to space or access limitations or where an on-engine check has shown a problem exists.

Warning

Always wear safety glasses.

Removal of an original hose clamp is a 3-stage operation. Place the turbocharger on a suitable workbench.

1. Using a small flat screwdriver, carefully unhook the location barb.
 2. Grab the free end of the clamp with long nose pliers to open the crimp.
 3. Pull the flexible hose from the actuator spigot.
- Discard the hose clips (75)*.

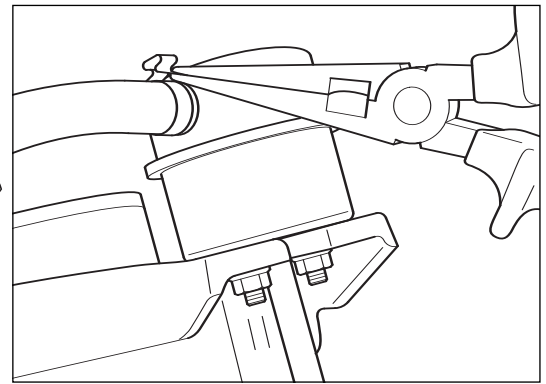
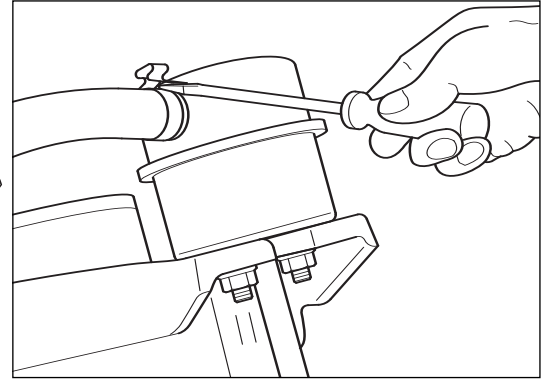

Warning

Avoid touching the wastegate rod end area as finger injury may result from sudden movement of the assembly when air pressure is applied.

Connect and secure the hose from the regulated compressed air supply to the actuator spigot.

Carefully apply pressure to the actuator from the regulated compressed air supply (Max 3 bar, 45 lbf/in²) and check for actuator movement.

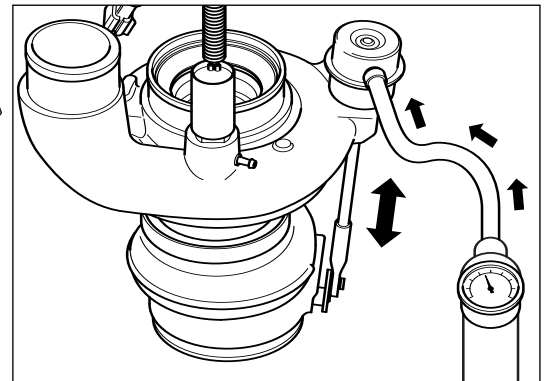

Actuation Checks

If rod does not move check wastegate actuator for air leaks. If air leak is found replace actuator in accordance with [Wastegate Actuator Replacement](#).

If no air leak is found and rod does not move, failure may be result of mechanical failure of actuator or seizure of wastegate valve mechanism.

Disconnect actuator and check in accordance with [Wastegate Actuator Check](#).

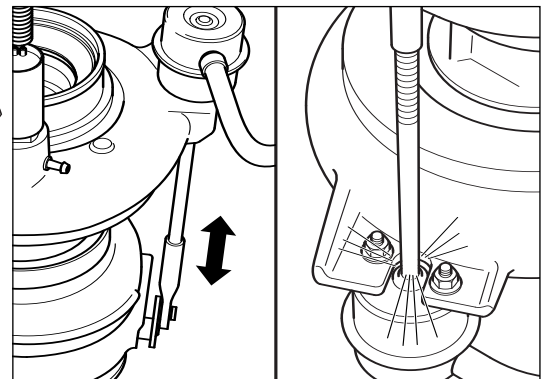

Wastegate Actuator Check



Warning

Always wear safety glasses.

Using a small flat screwdriver, carefully remove the end link retaining clip.

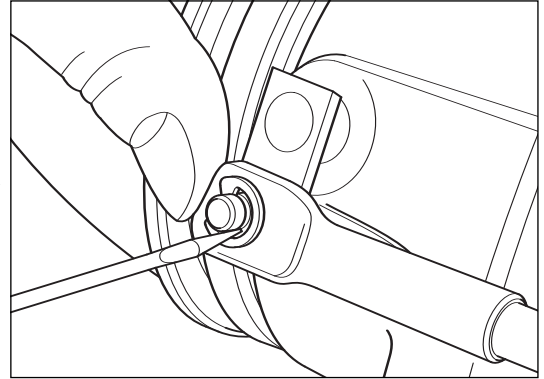

Caution

Do not rotate actuator rod relative to actuator as this can damage actuator internal components.

Warning

The rod may retract very quickly when freed from lever arm. Keep fingers away from mechanism.

Gently apply a small amount of air to the actuator and when/if the rod end moves, carefully slide the end link off the valve lever arm. If the actuator rod does not move, a screw driver may be required to prise the end link off the lever arm.

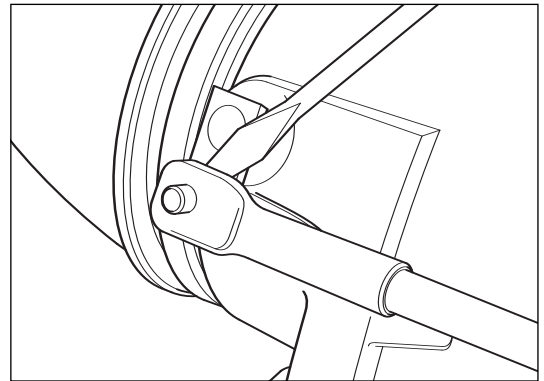

Apply 300 kPa (45 lbf/in²) to the actuator. If actuator rod does not move, refer to [Actuator Removal](#).

If actuator rod does move, check wastegate valve mechanism according to the procedure in [Wastegate Mechanism Check](#).

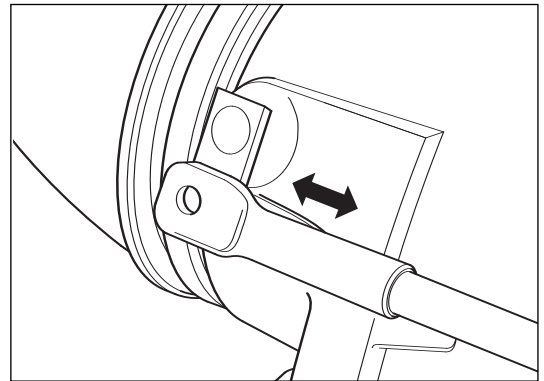

Actuator Removal



Warning

Always wear safety glasses.

Using a small flat screwdriver, carefully remove the end link retaining clip.

Caution

Do not rotate actuator rod relative to actuator as this can damage actuator internal components.

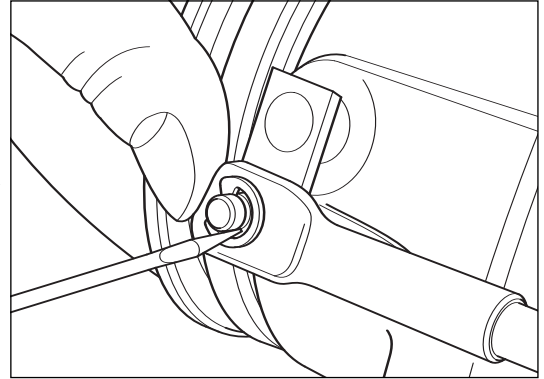

Gently apply a small amount of air to the actuator and when/if the rod end moves, carefully slide the link end off the valve lever arm. If the actuator rod does not move, a screw driver may be required to prise the link end off the lever arm.

Warning

The rod may retract very quickly when freed from lever arm. Keep fingers away from mechanism.

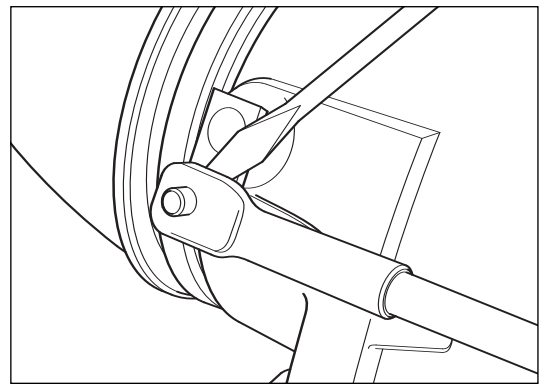

M6 x 1 (10 mm)

Remove actuator lock nuts.

Caution

Do not adjust the rod end link. This setting is critical to actuator performance.

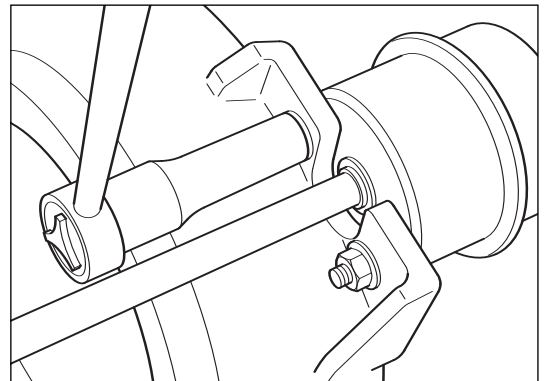

After removal of hose clamp and hose, lift the actuator away from the bracket until the studs clear the location holes.

Discard hose clamps (75).

To replace actuator refer to [Wastegate Actuator Replacement](#).

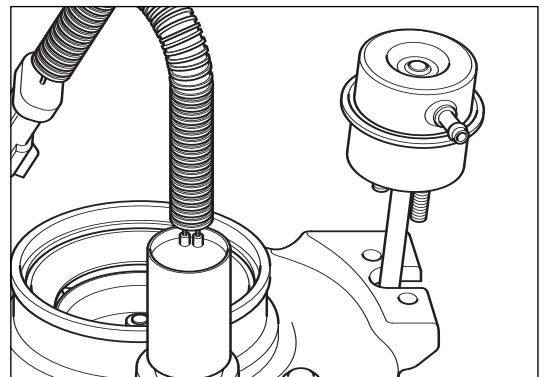

Wastegate Mechanism Checks



Carefully move the lever arm up and down. If the arm moves freely by hand, then re-check for movement of actuator rod.

If the lever arm is seized, the turbocharger will require replacement. However, it may be possible to free the lever arm.

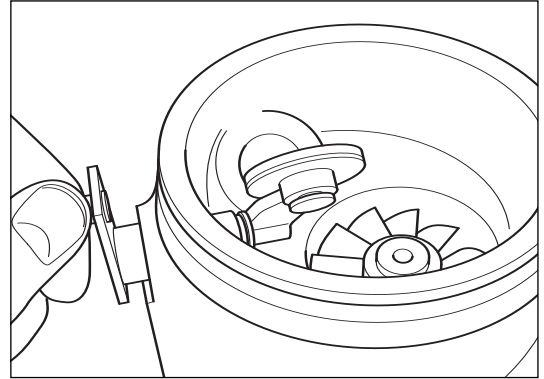

Soak wastegate valve and lever mechanism in penetrating oil.

Warning 
Always wear safety glasses.

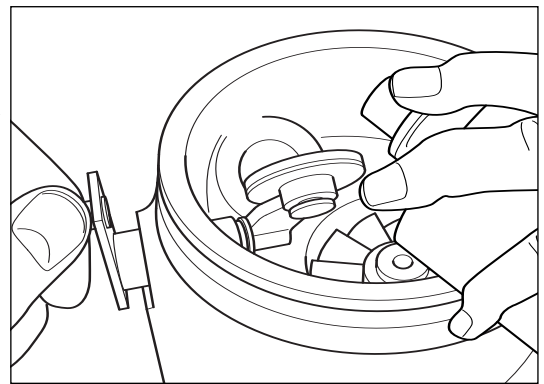

Caution 
Extra care must be taken when attempting to free the valve mechanism. Any damage will result in the replacement of the turbine housing.

Clamp a pair of quality mole (vice) grips to the lever and gently apply pressure to rotate the lever arm in an arc.

If this process does not free the valve mechanism, a new turbocharger must be fitted.

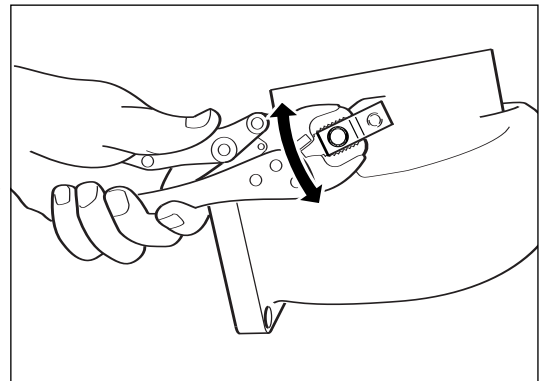

Caution 
If the wastegate valve mechanism shows any fault, the turbocharger must be replaced. Using damaged turbine housings will lead to inferior performance of the turbocharger, and risk of irreparable damage to both turbocharger and engine.

Radial cracks can occur around the valve seat when the turbocharger has been abused or overheated.

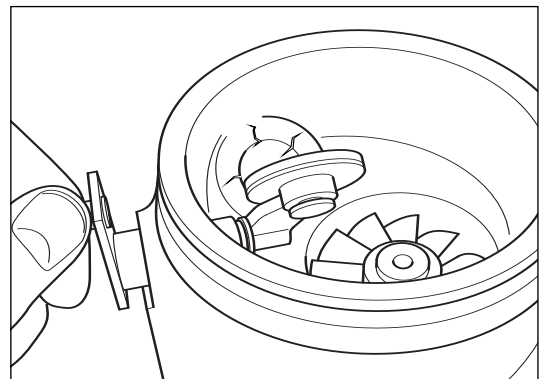



After freeing wastegate valve mechanism always check for damage to cross shaft and bearings.

Where the cross shaft axial or radial clearance is high, replace turbocharger.

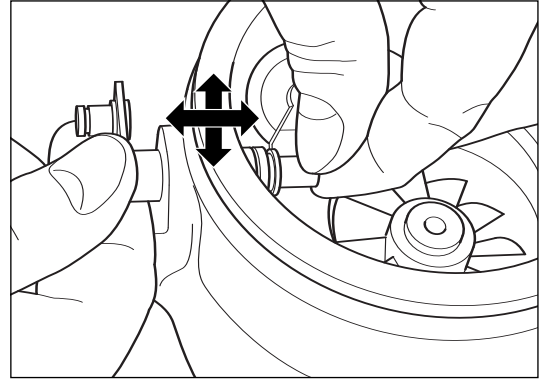

Lever arm pin can be worn by partial seizure of the valve mechanism. Scoring may be caused by arduous local environmental conditions.

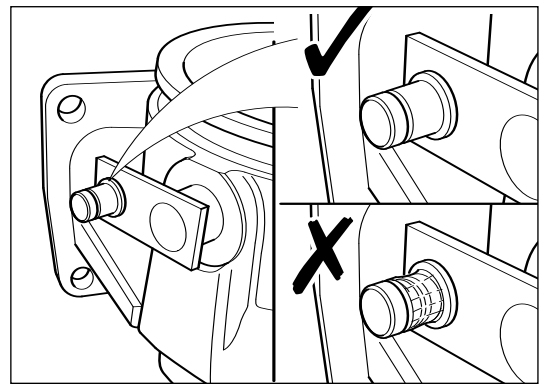

Valve mechanism seizure can also lead to elongation of the rod end bore which locates on the lever arm pin. This must not exceed 0.50 mm (0.020 in).

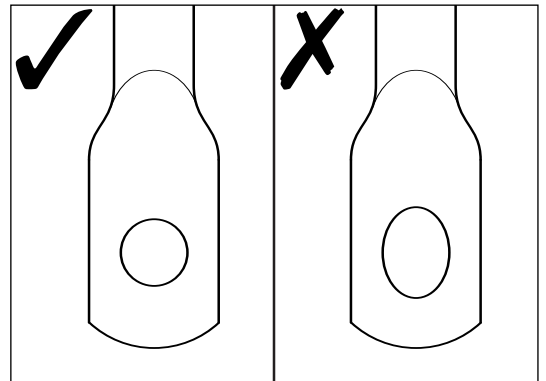

Caution If the actuator shows any fault, it must be replaced.

Wastegate Actuator Replacement



Caution 

Contact your local approved agent for the correct replacement actuator kit (74). It is important to quote the correct turbocharger assembly number, serial number and type from the dataplate to ensure the supply of the correct pre-set actuator.

Note

When refitting existing actuator the end link will be locked in the correct setting.

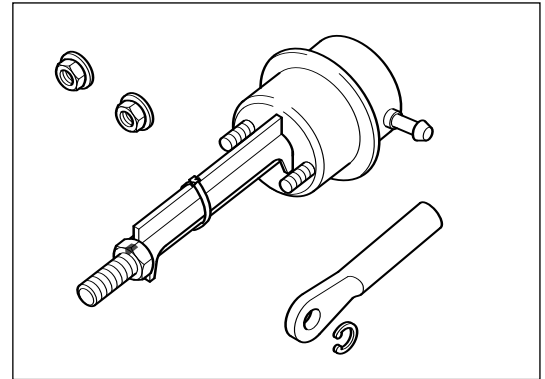

Thread new end link several turns on to the shaft of the new pre-set actuator assembly.

Hold the actuator assembly with the spine of the spacer piece upright. Rotate the valve mechanism lever arm to close the wastegate valve (pushed towards the compressor end). Fit end link over the lever arm pin.

Attempt to slide the actuator over its retaining bracket. If the actuator fouls on the bracket or there is significant clearance between bracket and actuator base, actuator rod length requires adjustment.

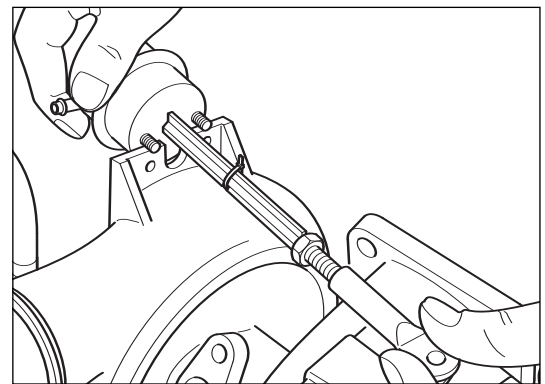

Note

Do not fit the wastegate studs to the bracket at this stage.

To adjust the length of the actuator assembly, remove from the turbocharger. Rotate the end link to shorten or lengthen the rod as appropriate. Re-fit, until the underside of the actuator will just fit over the bracket mounting face with less than 0.5 mm (0.020 in) gap.

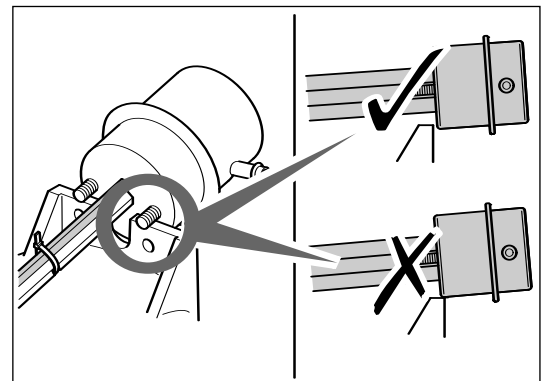

Caution 

Do not apply force to push the actuator on to the mounting face of the bracket.

The rod length setting is correct if, by rotating end link clockwise by a half turn, the actuator body fouls on the bracket.

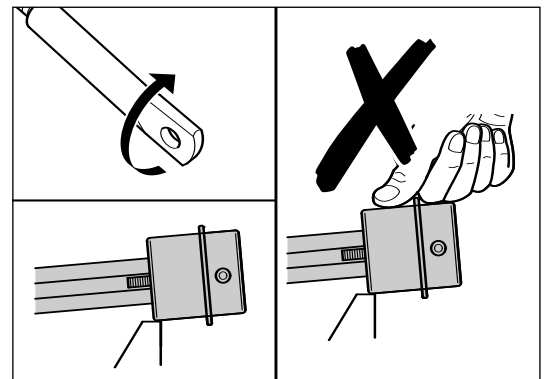



M6 x 1 (10 mm)

Remove the actuator assembly from the lever arm ensuring that the end-link does not rotate. Fit actuator mounting studs into their locating holes (or slots) in the bracket. Fit both actuator mounting nuts and torque tighten to the value shown in the [Service Data Sheet](#).

Warning

Always wear safety glasses.

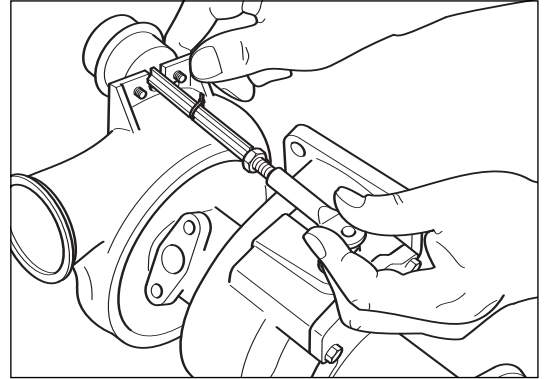
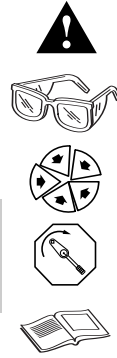

Re-fit end link to the lever arm pivot pin. Fit new e-clip using special tool Part No. 4027204 to retain rod end on pin.

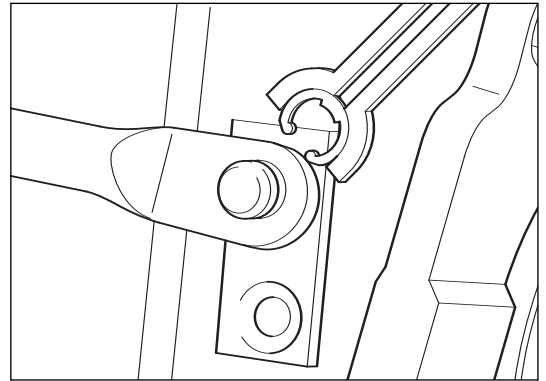

5/16 - 24 UNF 2B (1/2 in)

Loosen spacer piece by turning jam-nut anti-clockwise (counter-clockwise). Remove and discard tie wrap and spacer piece.

Continue turning jam-nut in the same direction, and torque tighten against end link to value shown in [Service Data Sheet](#).

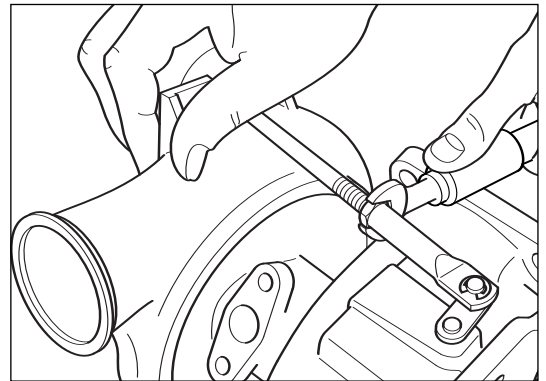

New pre-set actuator kits (74)* may be supplied with a tamper resistant break off nut (143) instead of a jam nut (128) to secure the end link in its correct pre-set position.

To install a tamper resistant actuator:

1. Slacken the shear nut from the spacer spine.
2. Continue to turn the nut until it contacts the pre-set end link.
3. Continue tightening until the hex flats break off leaving only the cone section in tight contact with the end link.

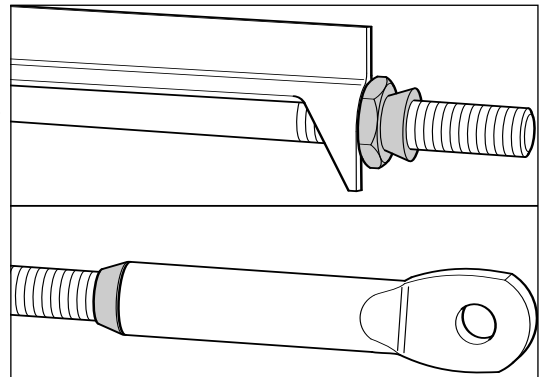
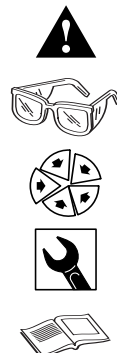



(25 mm)

Refit command valve in accordance with [Command Valve Removal and Refitting](#).

Warning

Always wear safety glasses.

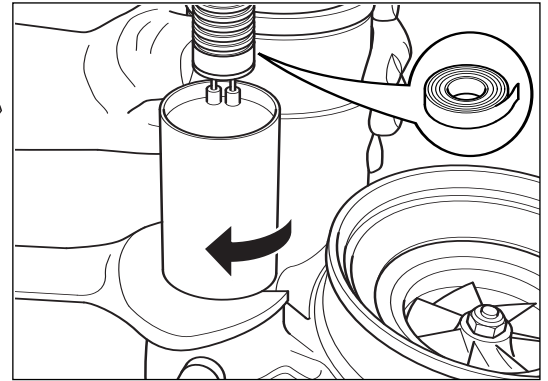

Caution

Before mounting turbocharger on engine, check for full and free wastegate movement, previously described in [Wastegate Actuator Checks](#).

Refit the air supply hose between actuator and command valve with new hose clamps (75)*. Clamps should be crimped closed using pliers. Crimp gap will vary due to spring back and hose type but will not be less than 0.6 mm (0.0025 in).

Suitable alternative hose clamps can be used.

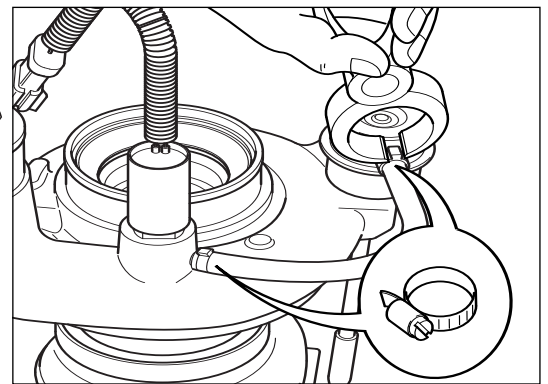

Command Valve



Valve Check

Warning

Ensure engine start key is in off position

Do not remove command valve from turbocharger at this stage. To check electrically, use a multi-meter to check resistance between pins 1 and 2. The resistance for the 12 V command valve should be a minimum of 6.0 Ohm at 20°C.

Where minimum resistance is not achieved, replace in accordance with [Command Valve Removal and Refitting](#). A service kit (169) is available from your approved Holset service agent.

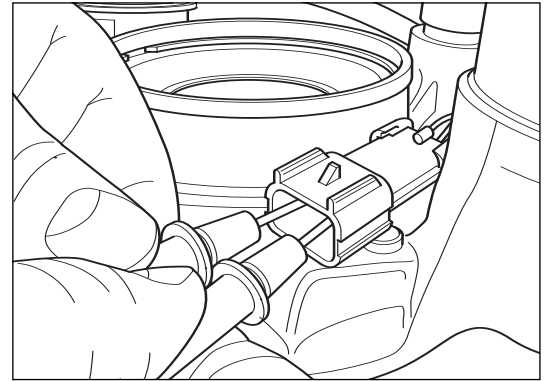

Valve Removal and Refitting

(25mm)

Warning

Always wear safety glasses.

Loosen command valve using open ended thin section spanner. The spanner is a standard proprietary catalogue item.

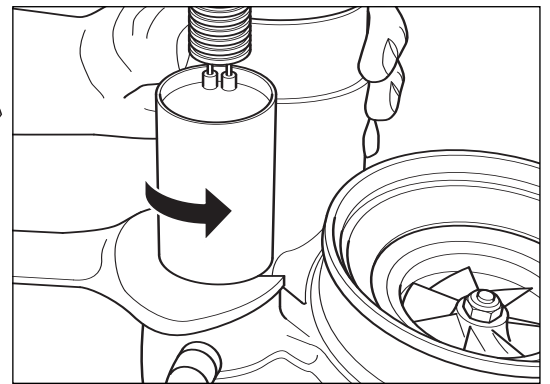

Warning

If there is any possibility that the seal has been subject to fire, always wear neoprene gloves when handling.

Unscrew valve ensuring not to damage three o ring seals, flying lead or connector.

All command valves which have passed the electrical resistance check should be cleaned in accordance with [Command Valve Cleaning](#).

Ensure cleaned or replacement command valve (169)* is fitted with three o ring seals (27)* before inserting into compressor cover screwed location.

An o ring service kit is available from your approved Holset service agent.

Insert command valve carefully avoiding damage to o ring seals. Hand tighten command valve. Using open ended thin section spanner, continue to tighten by rotating through 17 degrees.

Where a calibrated torque wrench is available with suitable spanner detail, refer to [Service Data Sheet](#) for torque setting.

Fit split conduit convolute around electric cables and secure with 4 pieces of tape at ends and equally spaced along length.

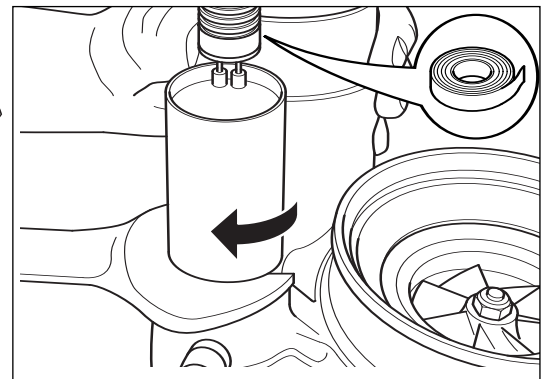
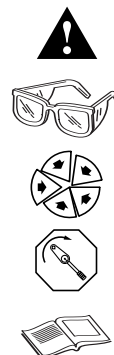
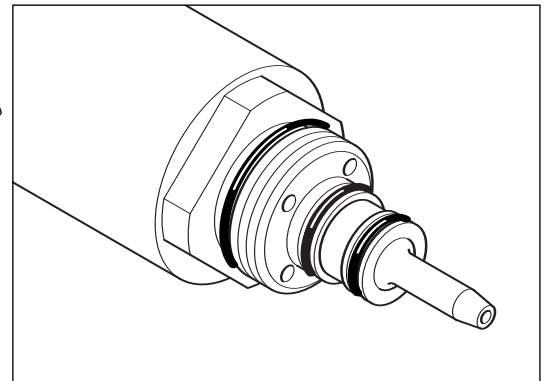
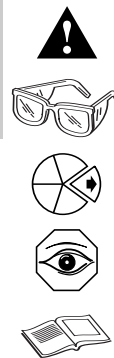



Valve Cleaning

Warning

Always wear safety glasses.

The command valve uses turbocharger compressed air as input pressure. The air supply is taken from the centre of the air stream so dirt build-up should be minimal and restricted to soft carbon deposits. It is still advisable to clean air passages before refitting the valve.

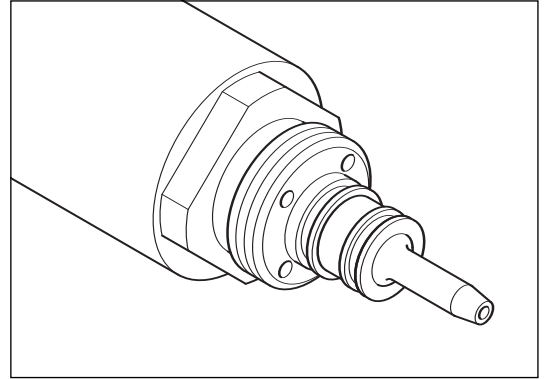

Warning

Always remove o ring seals before cleaning. If there is any possibility that the seal has been subject to fire, always wear neoprene gloves when handling.

Mechanical cleaning of the valve probe can be achieved using either a 1 mm diameter steel wire or if a welding torch cleaning set is available, a probe of the same diameter.

Caution

Welding torch cleaners are abrasive. Do not damage valve probe bore during any mechanical cleaning process.

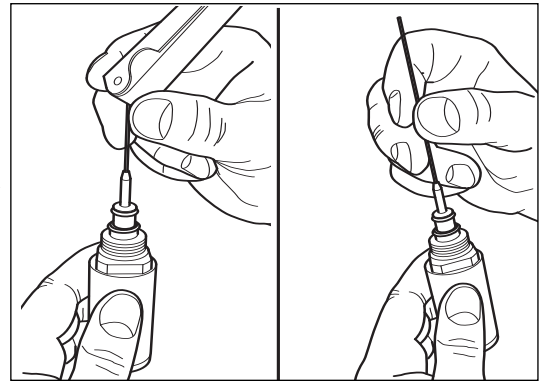

Use compressed air to purge the valve passages of loose debris

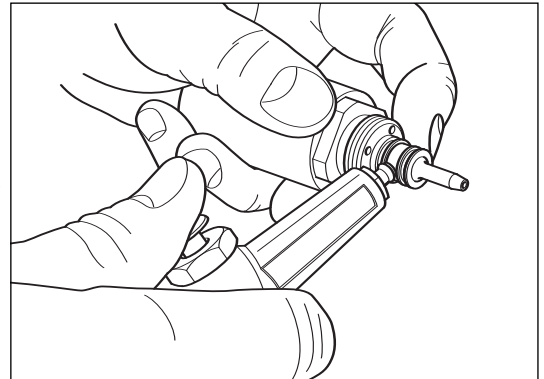

The command valve can be cleaned by soaking the valve in a non-corrosive low flash point metal cleaner or using an ultrasonic cleaning bath.

Caution

Do not submerge flying lead connector in cleaning fluid. Always remove o ring seals before cleaning.

Dry the valve using compressed air.

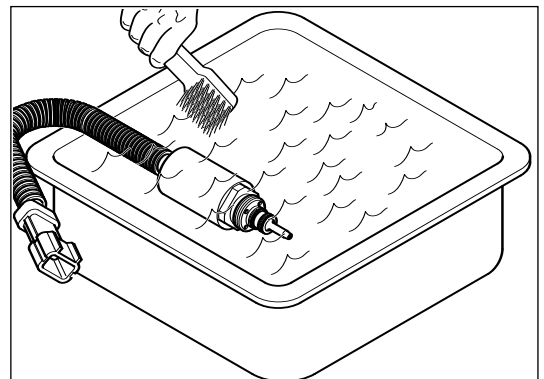



Holset HE351CW

Service Repair Manual

Cummins Turbo Technologies Ltd.
Aftermarket Division
Croset Avenue
Huddersfield
West Yorkshire
HD1 6SE
www.holsetaftermarket.com