



TURBOCHARGERS

# Holset HY35W

## Service Repair Manual

### WARNING

-  Turbochargers can be hazardous when not used as specified by the manufacturer. To prevent damage and personal injury:
- Always use the turbocharger part number specified by the engine manufacturer.
  - Use only in applications approved by the engine manufacturer.
  - Do not touch before checking surface temperatures.
  - Do not work on a running turbocharger or engine.
  - Do not modify the turbocharger in any way.
  - Disassemble and re-assemble using the engine manufacturer's instructions.
  - Use only approved spare parts.
- For advice on the safe use of turbochargers contact [www.holset.com](http://www.holset.com)**

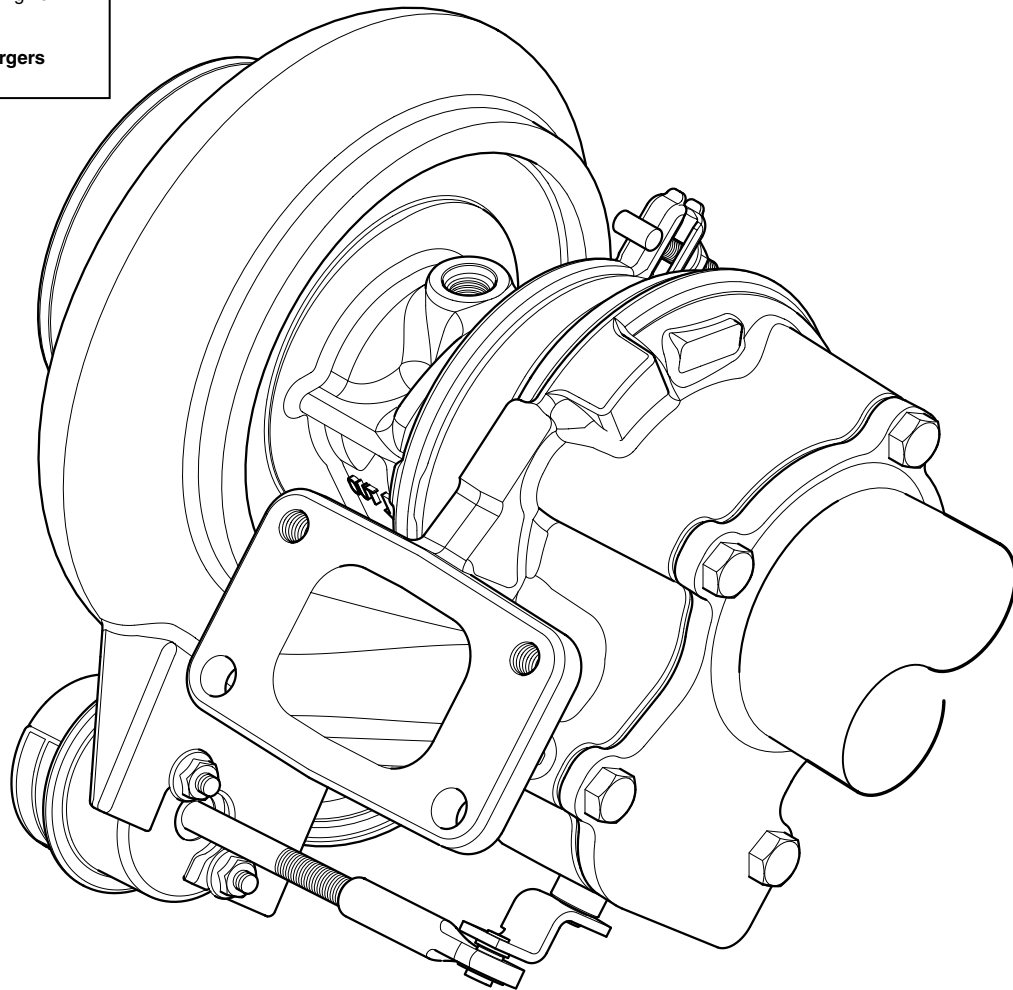

## **Foreword**

This publication was written to assist with installation, maintenance and overhaul of the Holset HY35W turbocharger. It is not a warranty of any kind expressed or implied.

The specifications and procedures in this manual are based on information in effect at the time of publication. Holset Service reserves the right to make any changes at any time without obligation. If differences are found between your turbocharger and the information in this manual, contact your local Holset approved agent.

The latest technology and the highest quality standards are used in the manufacture of Holset Turbochargers. When replacement parts are needed, we recommend using only genuine Holset parts.

# Table of Contents

## 1: Introduction

About the Manual .....	1:1
How to Use the Manual .....	1:1
How to Order Holset Original Parts .....	1:1
<b>Description and Operation of Turbocharger</b> .....	1:2
<i>General Information</i> .....	1:2
<i>Introduction to Wastegate Turbochargers</i> .....	1:2
<i>Notes, Cautions and Warnings</i> .....	1:3
<b>Installation Data</b> .....	1:4
<b>Installation Checklist</b> .....	1:5
<b>Symbols</b> .....	1:6

## 2: Component Identification

<b>Turbocharger Identification</b> .....	2:1
<i>Dataplate and CHRA (Core) of Turbocharger</i> .....	2:1
<i>Installation Options</i> .....	2:2
<b>Exploded Views</b> .....	2:3
<b>Component List</b> .....	2:6
<b>Purchasable Service Tools</b> .....	2:8

## 3: Troubleshooting and Diagnosis

<b>Fault Finding Chart</b> .....	3:1
----------------------------------	-----

## 4: Component Testing and Replacement

<b>Service Tools</b> .....	4:1
<b>On Engine Checks</b> .....	4:2
<b>Bearing Clearance</b> .....	4:5
<b>Turbine and Compressor Housings</b> .....	4:6
<b>Cleaning of Housings</b> .....	4:10
<b>Wastegate Actuator Checks</b> .....	4:12
<b>Actuator Removal</b> .....	4:14
<b>Wastegate Mechanism Check</b> .....	4:16
<b>Wastegate Actuator Replacement</b> .....	4:18

## 5: Turbocharger Service and Overhaul

<b>Service Tools</b> .....	5:1
<b>Disassembly</b> .....	5:2
<b>Component Cleaning</b> .....	5:7
<b>Inspection and Testing</b> .....	5:8
<b>Reassembly</b> .....	5:14

## 6: Service Data Sheets

<b>HY and VG Range Service Data Sheets</b> .....	6:1
--	-----

## About the Manual

The procedures in this manual were developed to instruct in the correct overhaul of the Holset HY35W turbocharger for optimum performance and minimum maintenance operation.

## How to Use the Manual

The manual is split into sections designed to provide service information in a logical sequence. The manual contains links to help the user navigate between relevant sections. Users who are unfamiliar with navigating in PDF documents are referred to Navigating in PDF documents in the **Adobe® Acrobat® Reader™** help file.



Contents is an interactive page with links to all the sections. It can be accessed from any page in the manual by clicking this icon.

Section 1 defines the layout of the manual, introduces the reader to the operation of the turbocharger and presents important installation guidelines.

Sections 2, 3 and 4 concentrate on turbocharger Component Identification, Troubleshooting and Diagnosis, Component Testing and Replacement.

Section 5 identifies the Service and Overhaul procedures to be followed in the unlikely event of a major turbocharger malfunction.

Section 6 quantifies build data to ensure the turbocharger will continue to operate to Holset Service standard on completion of overhaul.

Manual sections 1 to 5 where applicable, appear as a **self extracting** compressed file which is organised according to the steps needed to most easily and correctly maintain the operation of the turbocharger. Users are required to download this file to hard disk. Section 6 has its own file identity and resides at [www.holset.co.uk](http://www.holset.co.uk), so that Holset can update the Service Data as changes occur. The links between manual and service data are active only when the user is connected to the Internet.

Chapter 6 has an expiry date to encourage users to discard outdated saved or printed versions and always access the latest information available at [www.holset.co.uk](http://www.holset.co.uk).



When using the manual on-line this icon will link to Holset's website to help find your nearest agent for advice and how to order Holset original parts.

## How to Order Holset Original Parts

To make sure of optimum performance, certain items must be discarded during disassembly and replaced with new for reassembly. These items are indicated in the Service and Overhaul section with the use of a \* symbol. All items showing a \* are available in a basic overhaul kit.

To get the correct parts for your turbocharger, refer to the 'component identification' section of this manual to help you find the following information:

- 1) Refer to the exploded view and component list to define the major components to be replaced.
- 2) Refer to the turbocharger's dataplate which will be found on the compressor cover or wastegate actuator to define the identifying information about your turbocharger build standard.
- 3) Contact your local Holset agent with component identification nos. and dataplate assembly no., serial no. and turbocharger type.
- 4) With this information, your local agent can provide you with the optimum kit of parts for re-assembling your turbocharger for continued long life operation.

# Description and Operation of Turbocharger

## General Information

A turbocharger is a mechanical device which uses the engine's exhaust gases to force more air into the engine cylinders. Hot exhaust gas energy is used to turn a turbine wheel and shaft. At the other end of the shaft is the compressor impeller (or compressor wheel), which draws in air and forces it into the engine cylinders.

Supplying increased air mass flow to the engine provides improved engine performance, lower exhaust smoke density, improved operating economy and altitude compensation. The turbocharger has proven to be one of the most beneficial devices for improving engine performance. It performs its job very well, as long as it is properly cared for.

## Introduction to Wastegate Turbochargers

### The need for wastegated turbochargers

A standard turbocharger can be perfectly matched to only one particular engine condition, eg maximum torque speed or maximum load speed. At this engine speed, the turbocharger supplies the optimum mass of air to give the required air/fuel ratio. At other speeds the air/fuel ratio cannot be held at the optimum hence fuel consumption and emission levels worsen.

Engine emission legislations have forced manufacturers to improve their engine efficiencies, particularly at low speeds where low air/fuel ratios cause high smoke levels.

The Holset integral wastegate turbocharger is a cost effective solution to this problem and for a small increase in complexity, a simple variable flow turbine housing has been achieved.

Integral wastegate turbochargers have been available for passenger cars for many years. Holset has developed such a turbocharger with components designed for extended life equal to that of standard commercial vehicle turbochargers.

### The importance of correctly servicing the wastegate actuator mechanism

A wastegate turbocharger requires accurate setting at point of manufacture. It is very important to adhere to setting limits when servicing the turbocharger, as failure to do so could result in turbocharger or engine failure.

### Effects of wrong setting

Possible consequences if the actuator is set to give a boost pressure too low:-

- Engine runs fuel rich
- Exhaust temperature increase
- Hydrocarbon levels increase
- High cylinder temperature risks damage to engine pistons
- Fuel consumption increase
- Smoke levels increase
- Risks of failing emissions tests

Possible consequences if the actuator is set to give a boost pressure too high:

- Engine runs fuel weak (lean)
- Excessive boost overspeeds turbocharger
- Increased cylinder pressure risks damage to engine head gasket, pistons and valves
- Nitrous oxide levels increase
- Turbocharger bearing failure and wheel fatigue problems
- Intercooler load increases causing engine to overheat, risking piston damage

## Notes, Cautions and Warnings

**Notes, Cautions and Warnings** are used in this manual to emphasise important or critical instructions.

### Note

Information which is essential to highlight.

### Caution

Maintenance or Service procedures which if not strictly followed, will result in damage or destruction of the turbocharger.

### Warning

Maintenance or Service procedures which if not correctly followed will result in personal injury or loss of life.

### Note

Holset turbochargers can be remanufactured using recovered parts. Where it is necessary to dispose of components or whole turbochargers, an environmentally responsible process such as recycling should be used, with due regard to local laws.

### Note

Holset Service receives many turbocharger returns that are no fault found. Before assuming the turbocharger is not performing to specification always refer to the engine diagnostic system and the troubleshooting diagnostic procedures of this manual.

### Warning

Turbocharger surface temperature during operation can achieve 700°C (1300°F). The HY35W turbocharger weighs up to 9.1kgs (20.1 lb) and is fitted with external parts that are sensitive to manual handling.

### Caution

This turbocharger may have been manufactured using the 'core balance' process and therefore **MUST** be check balanced on rebuild.

A core balanced turbocharger will not have any co-relation marks. If you intend to overhaul/repair a core balanced turbocharger, and do not have access to a core balancing machine, we recommend that you make your own rotor co-relation marks during disassembly so that these parts can be reassembled in the same relative positions.

Balance limits for turbocharger rebuild are shown on Holset's Service Data Sheet.

It is important to note that operating a turbocharger with a rotor or core balance level greater than the published limits could cause turbocharger or engine failure. If you are in any doubt regarding the balancing process, please contact an approved Holset agent for assistance.

### Caution

Never remove the wastegate actuator or mounting bracket from the turbine housing, unless the actuator is to be renewed. It is possible to leave the turbine housing, bracket and actuator as an assembly while servicing the turbocharger.

Never adjust the link-rod of an assembled wastegate turbocharger. The link-rods are set by the O.E. supplier to precise limits which must be adhered to.

Always check that the actuator and wastegate mechanism is still in good working order, before proceeding with disassembly of your wastegate turbocharger.

### Warning

Some parts are manufactured in Viton that requires special treatment in the case of repair and service after fire.

## Installation Data

1. Holset Service receives many turbocharger returns that are no fault found. Before assuming the turbocharger is not performing to specification always refer to the engine diagnostic system and the fault finding chart of this manual to make all the recommended health checks.
2. It is important that intake and exhaust systems are fitted in accordance with the recommendations of the Equipment and Engine manufacturers. Limiting mass inertia loading is critical to turbocharger whole life operation. Maximum engine vibration input must not exceed 10g.
3. The air filter must remove particles greater than 5µm at an efficiency of 95% and be of sufficient capacity to match the air consumption of the engine. Recommended filters should always be used with a pressure drop indicator. Intake systems must be capable of withstanding depressions up to 6.9 kPa (1.0 lbf/in<sup>2</sup>).
4. Hose and clip connections of intake manifold systems must be capable of withstanding the turbocharger pressure ratio. V band clamps are preferred and must be used above 3:1 pressure ratio.
5. Exhaust systems must be capable of operating at exhaust back pressures of up to 10 kPa (1.5 lbf/in<sup>2</sup>). This limit is increased to 13.4 kPa (2.0 lbf/in<sup>2</sup>) if a catalytic converter is fitted. Exhaust brake applications are permitted to impose 450 kPa (65.3 lbf/in<sup>2</sup>) back pressure.
6. Oil should be filtered to 10µm with efficiency of 60% TWA (Time Weighted Average) /20 µm with efficiency of 85% TWA. Efficiency assessed using ISO Standard 4572/SAE J 1858.
7. The oil quality must be as specified by the engine manufacturer and will be a minimum API SE - CD (MIL - L - 2104C) specification. Improved life can be obtained by using super high performance diesel (SHPD) oils, particularly in industrial applications which use extended oil drain periods.
8. Normal oil temperature is 95+/-5°C (203+/-9°F). It should not exceed 120°C (248°F) under any operating condition.
9. Any pre-lube oil must be clean and meet the minimum CD classification.
10. The orientation of turbine housing, bearing housing and compressor cover is fixed according to application. During installation, do not attempt to rotate these components. Inclined turbocharger installation is not recommended. If an installed angle is necessary, oil inlet centreline must be +/- 10 degrees from vertical and rotor centreline +/- 5 degrees from horizontal.
11. Holset permits oil return pipes to decline at an overall angle of not less than 30 degrees below horizontal. All turbocharger applications require a pipe of internal diameter greater than 14 mm which has integrated connectors. To ensure oil returns into the engine under all operating conditions, the return connection into the engine sump must not be submerged and the outlet flange of the turbocharger must be 50 mm above the maximum oil level of the engine sump pan. Crankcase pressure should be limited ideally to 0.8 kPa (0.12 lbf/in<sup>2</sup>) but 1.4 kPa (0.20 lbf/in<sup>2</sup>) can be accepted by reference to Holset.
12. Oil pressure of 150 kPa (20 lbf/in<sup>2</sup>) must show at the oil inlet within 3 - 4 seconds of engine firing to prevent damage to turbocharger bearing system. A flexible supply pipe is recommended.
13. The minimum oil pressure when the engine is on load must be 210 kPa (30 lbf/in<sup>2</sup>). Maximum permissible operating pressure is 500 kPa (72 lbf/in<sup>2</sup>) although 600 kPa (88 lbf/in<sup>2</sup>) is permitted during cold start up. Under idling conditions pressure should not fall below 70 kPa (10 lbf/in<sup>2</sup>).
14. Recommended oil flows for the turbochargers are 2 litre/min at idle and 3 litre/min above maximum torque speed.
15. Do not use liquid gasket substances or thread sealant as any excess can enter the turbocharger oil system to obstruct flow.

**Note:**

100 kPa = 1bar (14.5037 lbf/in<sup>2</sup> = psi).

## Installation Checklist

1. Always understand why the original turbocharger needs replacing before fitting another unit.
2. Check the turbocharger dataplate to ensure the Part No. is correct for the engine/application.
3. Check the engine exhaust, intake and aftercooler systems are clean and without obstruction i.e. free from oil, gasket pieces, dust/dirt/carbon or foreign objects.
4. Replace the oil and air filters using replacement parts specified by the equipment manufacturer.
5. Change the engine oil using the type specified by the engine manufacturer.
6. Check that the turbocharger oil inlet and drain pipes and connectors are clean, free from obstruction and will not leak under pressure.
7. Check that the coolant pipes of water cooled bearing housing applications and connectors are clean, free from obstruction and will not leak under pressure.
8. To pre-lube the turbocharger bearings, pour some clean engine oil into the oil inlet and rotate the turbocharger rotor assembly by hand.
9. Check that the exhaust manifold flange is flat and undamaged. Mount the turbocharger on the flange and check that the turbine inlet gasket fits properly without obstructing the gas passages.
10. Assemble the air intake and boost outlet connections. Check that the connections are well made and will not leak in use.
11. Check the exhaust system is fitted using the original mounting arrangement provided by the equipment manufacturer. Always re-fit any supports/brackets back in position to ensure the system is correctly supported.
12. Assemble the exhaust system to the turbine housing outlet. Check that the gasket/connection is well made and will not leak in use.
13. Assemble any coolant pipes and check that the connections are well made, without obstruction and will not leak in use.
14. Assemble the turbocharger oil inlet pipe and check that the connection is clean, well made and will not leak in use.
15. Check all clamps and fasteners are correctly tightened to the torque recommended by the equipment manufacturer.
16. Connect the air pipe from the compressor housing to the wastegate actuator ensuring the pipe bore is clean and dry before fitment.
17. Make any ECU checks recommended by the engine manufacturer.
18. Crank the engine WITHOUT firing until engine oil flows out of the turbocharger drain flange.
19. Assemble the oil drain pipe and check that the connection is well made, without obstruction and will not leak in use.
20. Start the engine and run at idle speed for approximately 1 minute so that the oil supply system is fully operational.
21. Accelerate the engine and check that there are no leaks/obstructions of air/oil/coolant/gas under pressure.
22. Check that no hose or connection deforms under normal operation.
23. Before switching off the engine, leave it running at idle speed for at least 1 minute to cool the turbine.



# Symbols

## Symbole - Deutsch

In diesem Handbuch werden die folgenden Symbole verwendet, die wesentliche Funktionen hervorheben. Die Symbole haben folgende Bedeutung:



**WARNUNG** - Unterhaltungs und Wartungsverfahren müssen genau befolgt werden, da ein Nichtbeachten zu Personenschäden oder tödlichen Verletzungen führt.



**ACHTUNG** - Falls Unterhaltungs und Wartungsverfahren nicht genau beachtet werden, kann der Turbolader dadurch beschädigt oder zerstört werden.



**AUSBAU** bzw. **ZERLEGEN**.



**EINBAU** bzw. **ZUSAMMENBAU**.



**INSPEKTION** erforderlich.



Teil oder Baugruppe **REINIGEN**.



**DIMENSION** - oder **ZEITMESSUNG**.



Teil oder Baugruppe **ÖLEN**.



**WERKZEUGGRÖSSE** wird angegeben.



**ANZUG** auf vorgeschriebenes Drehmoment erforderlich.



Sicherstellen, daß die **AUSWUCHTMARKEN** an der Rotor-Baugruppe richtig ausgerichtet sind.



Elektrische **MESSUNG DURCHFÜHREN**.



Weitere Informationen an anderer Stelle bzw. in anderen Handbüchern.



Schutzkleidung muß immer getragen werden.



Deutet an, daß Teile schwer sein können.



Website-Verzeichnis mit Ihrem nächsten Holset-Händler.



Gehe zu Inhalt

## Symbols - English

The following group of symbols have been used in this manual to help communicate the intent of the instructions. When one of the symbols appears, it conveys the meaning defined below.



**WARNING** - Maintenance or Service procedures which if not correctly followed will result in personal injury or loss of life.



**CAUTION** - Maintenance or Service procedures which if not strictly followed, will result in damage or destruction of the turbocharger.



Indicates a **REMOVAL** or **DISASSEMBLY** step.



Indicates an **INSTALLATION** or **ASSEMBLY** step.



**INSPECTION** is required.



**CLEAN** the part or assembly.



**PERFORM** a mechanical or time **MEASUREMENT**.



**LUBRICATE** the part or assembly.



Indicates that a **WRENCH** or **TOOL SIZE** will be given.



**TIGHTEN** to a specific torque.



Ensure that the **BALANCE MARKS** on the rotor assembly are in alignment



**PERFORM** an electrical **MEASUREMENT**.



Refer to another location in this manual or another publication for additional information.



Please wear protective clothing at all times.



Indicates components may be heavy.



Website access to find your nearest Holset Agent.



Go to Contents.

## Simbolos - Español

Los simbolos siguientes son usados en este manual para clarificar el proceso de las instrucciones. Cuando aparece uno de estos simbolos, su significado se especifica en la parte inferior..



**ADVERTENCIA** – Procedimientos de Mantenimiento o Servicio que al no seguirse resultarán en daños personales o pérdida de vida.



**ATENCION** – Procedimientos de Mantenimiento o Servicio que al no seguirse al pie de la letra, resultarán en el daño o la destrucción del turbosobrealimentador.



Indica un paso de **REMOCION** o **DESMONTAJE**.



Indica un paso de **INSTALACION** o **MONTAJE**.



Se requiere **INSPECCION**.



**LIMPIESE** la pieza o el montaje.



**EJECUTESE** una **MEDICION** mec-nica o del tiempo.



**LUBRIQUESE** la pieza o el montaje.



Indica que se dar- una **LLAVE DE TUERCAS** o el **TAMAÑO DE HERRAMIENTA**.



**APRIETESE** hasta un par torsor especifico.



Ceriórese de que est-n alineadas las **MARCAS DE BALANCE** en el rotor.



**EJECUTESE** una **MEDICION** eléctrica.



Para información adicional refiérase a otro emplazamiento de este manual o a otra publicación anterior.



Favor de siempre llevar ropa protectora.



Indica que los componentes pueden ser pesados.



Acceso a Sitio Web para localizar su agente Holset más cercano.



Ir a la tabla de materias

## Symboles - Français

Les symboles suivants sont utilisés dans ce manuel pour aider à communiquer le but des instructions. Quand l'un de ces symboles apparaît, il évoque le sens défini ci-dessous:



**ATTENTION DANGER** - Procédures de maintenance ou d'entretien qui, si elles ne pas observées correctement, auront pour résultat des lésions corporelles ou un décès.



**MISE EN GARDE** - Procédures de maintenance ou d'entretien qui, si elles ne sont pas observées strictement, auront pour résultat de causer des dégâts au turbocompresseur ou de conduire à sa destruction.



Indique une opération de **DEPOSE**.



Indique une opération de **MONTAGE**.



**L'INSPECTION** est nécessaire.



**NETTOYER** la pièce ou l'ensemble.



**EFFECTUER** une MESURE mécanique ou de temps.



**GRAISSER** la pièce ou l'ensemble.



Indique qu'une **DIMENSION DE CLE** ou **D'OUTIL** sera donnée.



**SERRER** à un couple spécifique.



S'assurer que les **REPÈRES D'ÉQUILIBRAGE** sur l'ensemble de rotor sont alignés.



**EFFECTUER** une **MEASURE** électrique.



Se reporter à un autre endroit dans ce manuel ou à une autre publication pour obtenir des information plus complètes.



Il faut toujours mettre vêtements de protection.



Indique que les composants peuvent être lourds.



Accès au site Web pour trouver l'agent Holset le plus proche.



Aller au sommaire

## Símbolos - Português

Os símbolos a seguir serão utilizados neste manual para facilitar a comunicação das instruções e seus significados estão descritos abaixo.



**ATENÇÃO** - Os procedimentos de Manutenção ou Serviços que não forem seguidos corretamente resultarão em ferimentos pessoais ou riscos de vida.



**AVISO** - Os procedimentos de Manutenção ou Serviço que não forem rigorosamente seguidos resultarão em danos ou destruição do carregador turbo.



Indica um passo de **DESMONTAGEM**.



Indica um passo de **MONTAGEM**.



Requer **INSPEÇÃO**.



**LIMPE** a peça ou conjunto.



Requer **MEDIÇÃO** mecânica ou de tempo.



**LUBRIFIQUE** a peça ou o conjunto.



Indica necessidade de **APERTO**.



**TORQUEAR** de acordo com o especificado.



Assegure-se de que as **MARCAS DE BALANCEAMENTO** do conjunto eixorotor estejam alinhadas.



Requer medição **ELÉTRICA**.



Procure em outra seção deste manual ou em publicação para obter informações adicionais



Por favor, sempre utilize EPI (Equipamento de Proteção Individual)



Indica que os componentes podem estar pesados.



Visite o Website para encontrar o seu Agente Holset mais perto.



Vá para Conteúdo

# Turbocharger Identification



## Dataplate

### Note

Dataplates may be fitted to the **compressor housing (8)** or the **wastegate actuator (73)**. The information from the dataplate must be quoted for service and parts support.

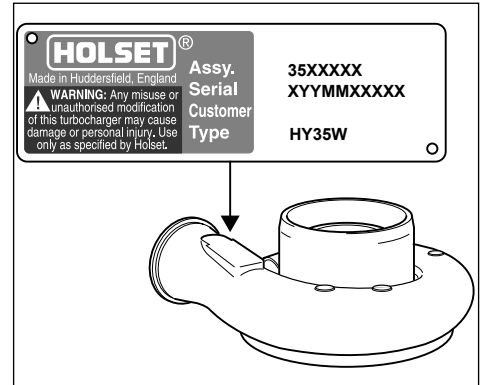
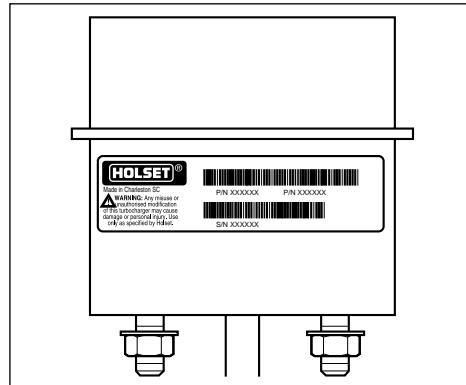

## Center Housing Rotating Assembly (CHRA) (2)

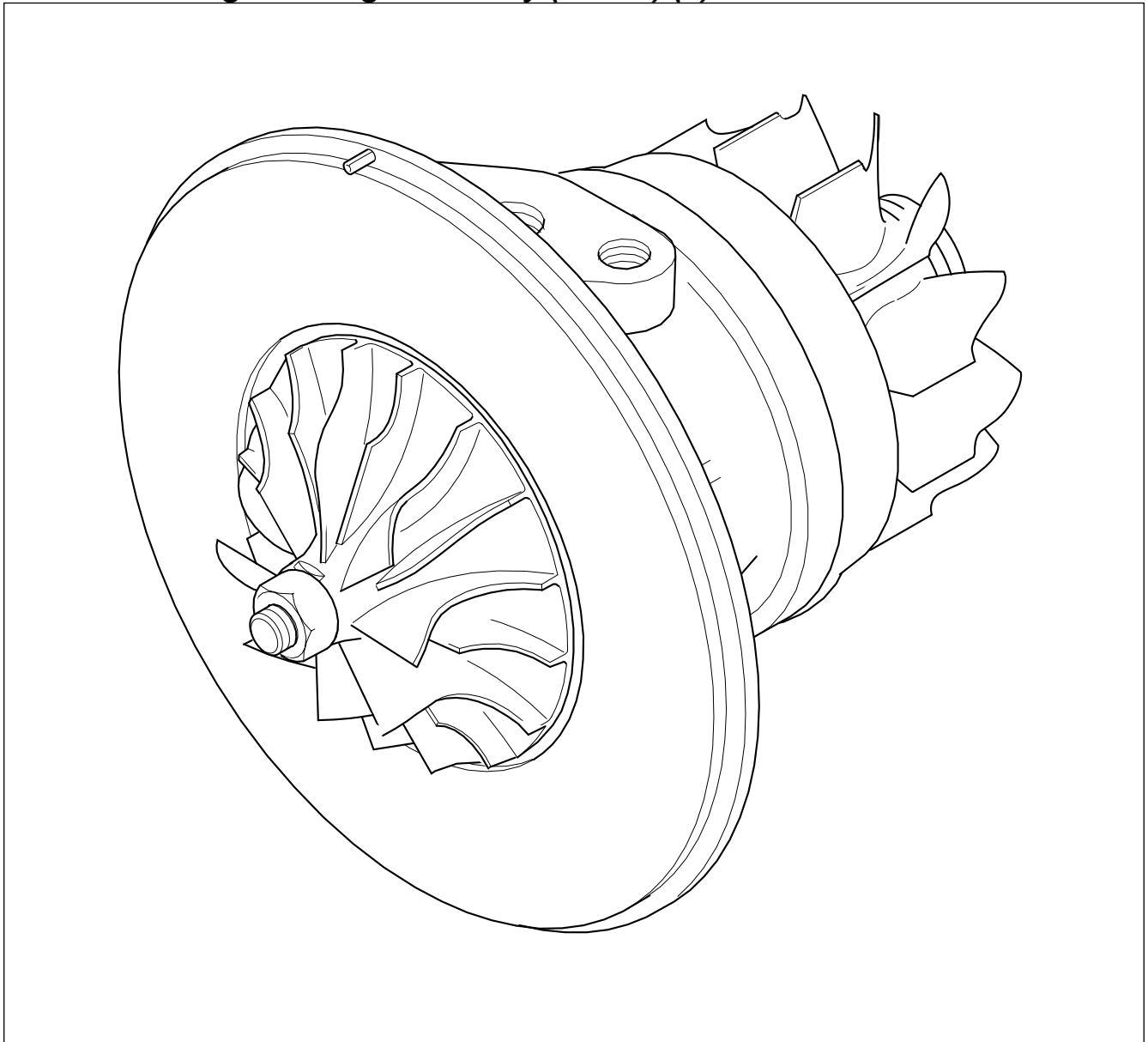



## Installation Options

### Type A

Integrated wastegate actuator air feed.

Application specific exhaust discharge pipe.

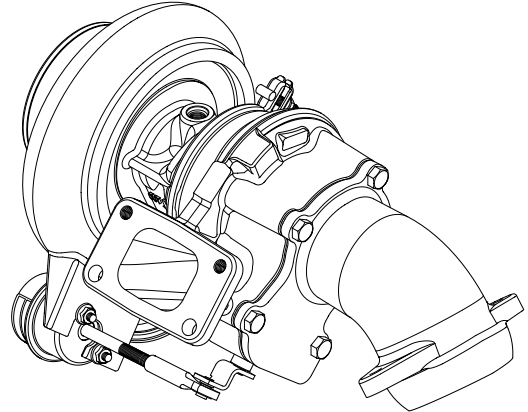

### Type B

Wastegate actuator with hose fed air supply.

Flanged exhaust outlet with open access to wastegate valve.

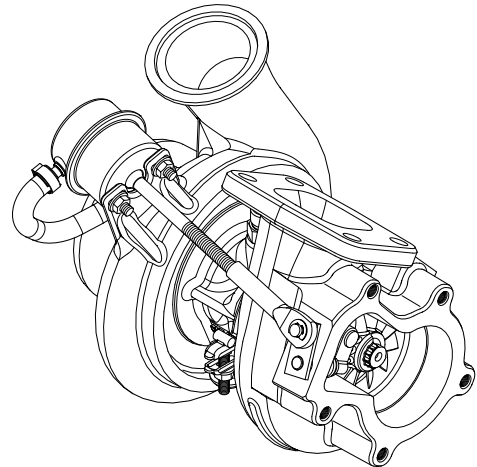

### Type C

Wastegate actuator with hose fed air supply.

Marman type exhaust outlet with enclosed wastegate valve.

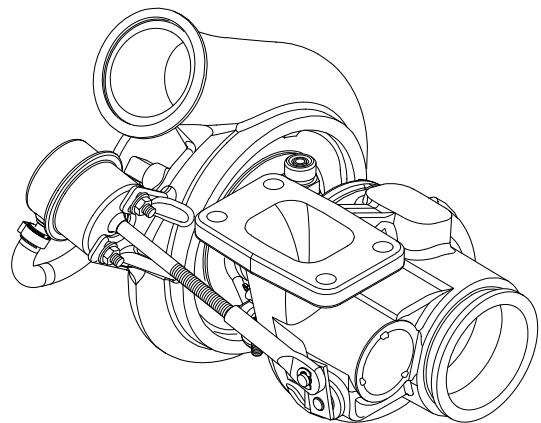

# Exploded View - HY35W Type A

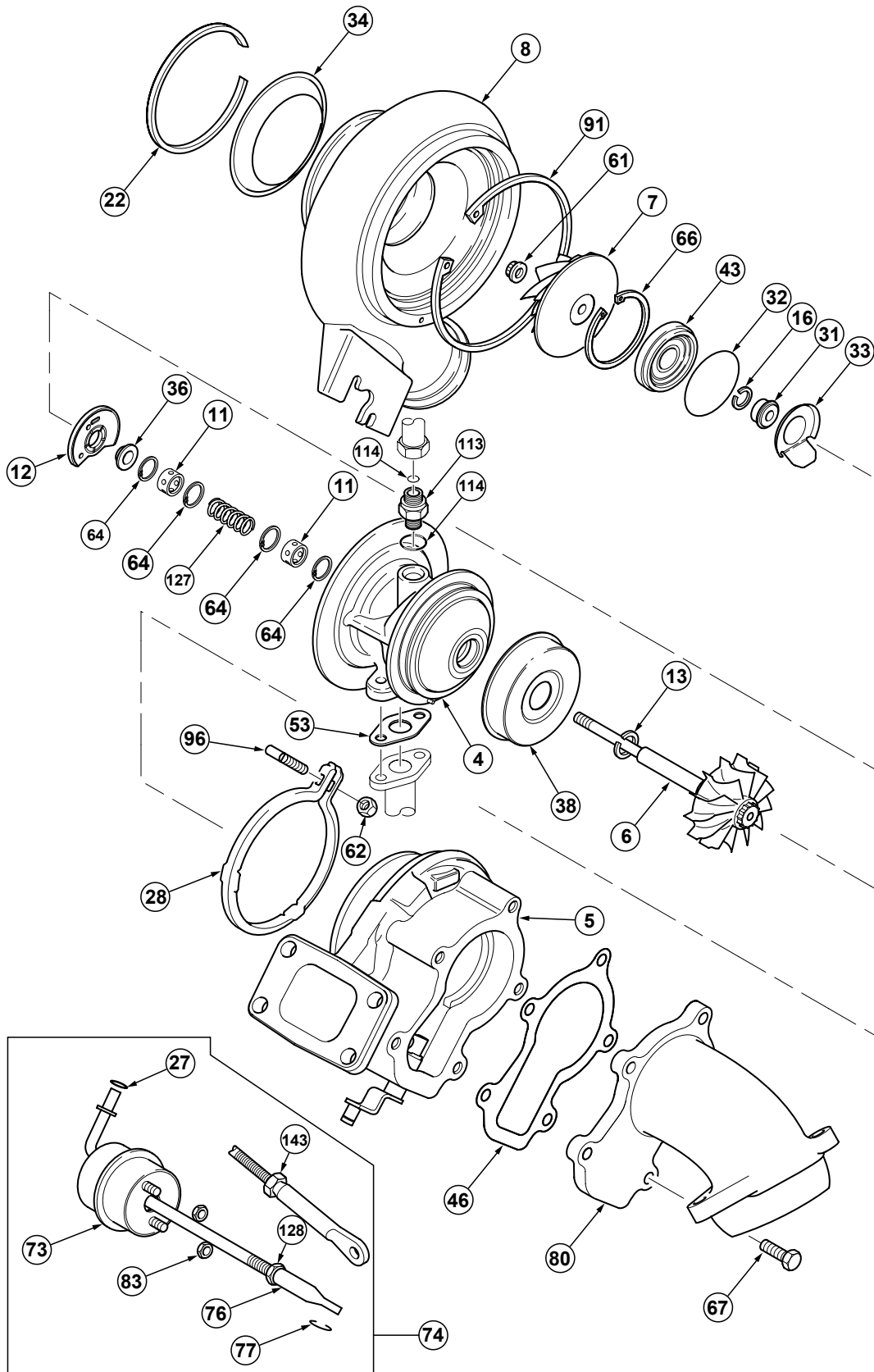

**Note**  
Exploded views represent a generic build standard. Parts may be added or subtracted in specific applications.





# Exploded View - HY35W Type C

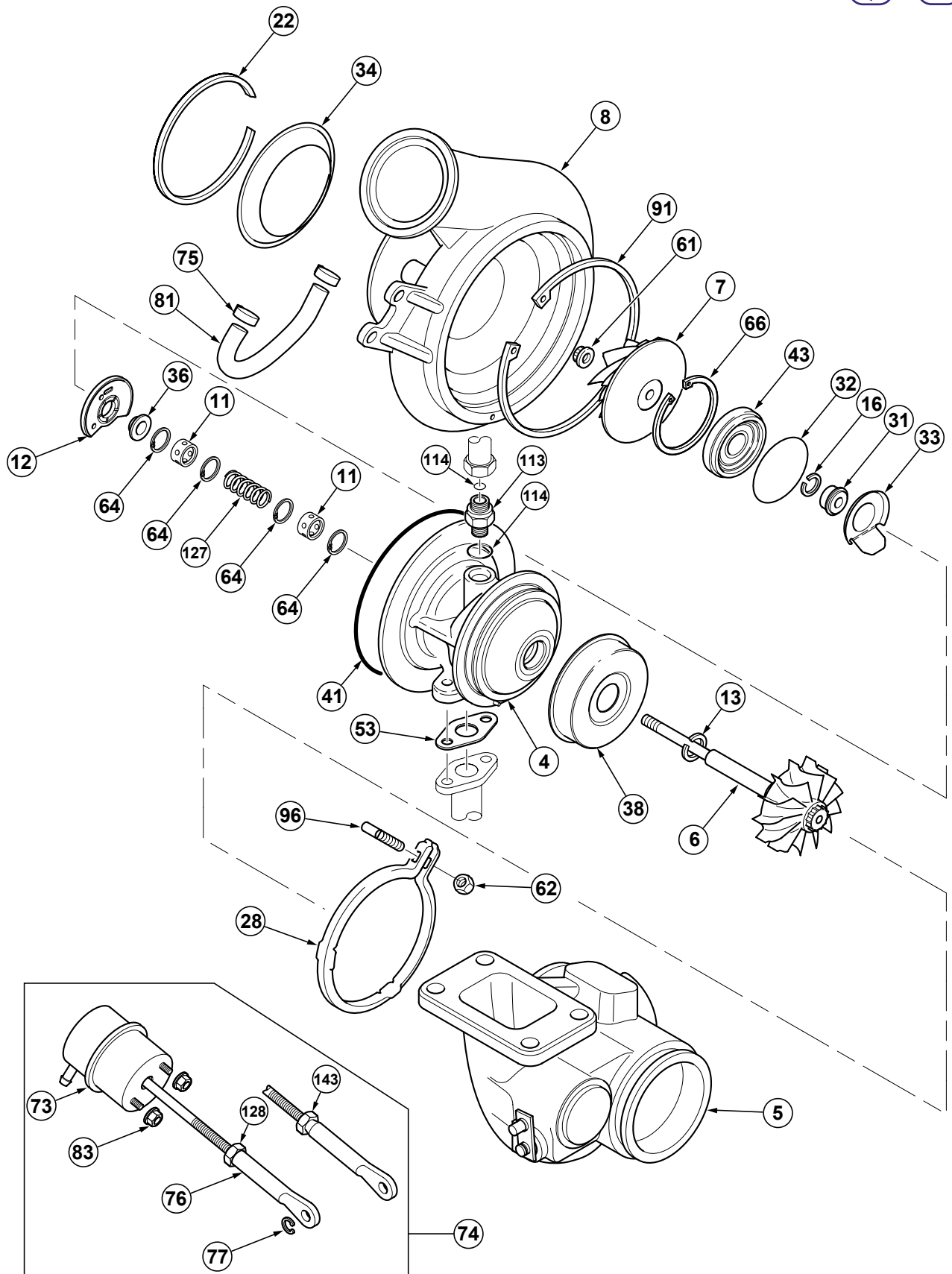

**Note**

Exploded views represent a generic build standard. Parts may be added or subtracted in specific applications.

## Component List - HY35W



Item No.	Description	Quantity
1	Repair Kit CHRA (Core) *	1
2	CHRA (Core)	1
4	Bearing Housing	1
5	Turbine Housing	1
6	Assembly, Turbine Wheel	1
7	Compressor Wheel	1
8	Compressor Housing	1
11	Journal Bearing *	2
12	Thrust Bearing *	1
13	Split Ring Seal, Turbine *	1
16	Split Ring Seal, Compressor *	1
22	Retaining Ring	1
28	V-Band Clamp, Turbine	1
31	Oil Slinger	1
32	O-Ring Seal, Bearing Housing *	1
33	Oil Baffle *	1
34	Inlet Baffle	1
36	Thrust Collar	1
38	Heat Shield	1
41	O-Ring Seal, Compressor Housing *	1
43	Oil Seal Plate	1
46	Gasket Coverplate	1
53	Gasket, Oil Outlet *	1
61	Locknut, Compressor Wheel	1
62	Locknut, V-Band *	1
64	Ring Retaining, Bearing (Snap Ring) *	2/4
66	Retaining Ring, Insert	1



<b>Item No.</b>	<b>Description</b>	<b>Quantity</b>
67	Cover Plate Bolts	5
74	Actuator Kit comprising	1
27	O-Ring Seal (Option)	1
73	Actuator	1
75	Hose Clip	2
76	End Link Assembly	1
77	End Link, Retaining Clip	1
83	Lock Nut, Actuator	2
128	Jam Nut	0/1
143	Breakoff Nut	0/1
80	Cover Plate	1
81	Hose	1
91	Retaining Ring, Compressor Cover	1
96	T-Bolt, V-Band	1
113	Adaptor, Oil Inlet	1
114	O-Ring Seal, Oil Inlet	2
127	Spacer Spring	1

# Purchaseable Service Tools



The following special tools can be purchased from your local Authorised Repair Location. The use of these tools is recommended and where used they are shown in the appropriate service procedure.

Part No.	Tool Description	Tool Illustration
3575186	Circlip Pliers	
56662	Circlip Pliers	
56663	Circlip Pliers	
56664	Circlip Pliers	
4027202	Wastegate Air Feed Adapter	
4027203	Wastegate Air Feed Adapter	
4027204	E-Clip Tool	

**Caution**  All Service and Maintenance settings are shown in Holset's Service Data Sheet. It is essential that these settings are used. Common tools found in mechanic's tool box not included.

# Fault Finding chart

	Engine Running Hot	Poor Transient Response	Smoke	Engine Lacks Power	Black Exhaust Smoke	Blue Exhaust Smoke	High Oil Consumption	Turbocharger Noisy	Cyclic Sound from the Turbocharger	Oil Leak from Compressor Seal	Oil Leak from Turbine Seal
<b>Dirty air cleaner</b> Clean or replace element according to manufacturer s recommendations	●	●	●	●	●	●	●			●	
<b>Restricted compressor intake duct</b> Remove restriction or replace damaged parts as required	●	●	●		●	●	●	●	●	●	
<b>Restricted air duct from compressor to intake manifold</b> Remove restriction or replace damaged parts as required	●	●		●	●			●			
<b>Restricted intake manifold</b> Refer to engine manufacturer s manual and remove restriction	●	●		●	●			●			
<b>Air leak in feed from air cleaner to compressor</b> Replace seals, gaskets or tighten fasteners as required								●			
<b>Air leak in feed from compressor to intake manifold</b> Replace seals, gaskets or tighten fasteners as required	●	●	●	●	●	●	●	●			
<b>Air leak between intake manifold and engine</b> Refer to engine manufacturer s manual and replace gaskets or tighten fasteners as required	●		●	●	●	●	●	●			
<b>Foreign object in exhaust manifold (from engine)</b> Refer to engine manufacturer s manual and remove obstruction				●	●	●	●	●		●	
<b>Restricted exhaust system</b> Remove restriction or replace damaged parts as required	●			●	●					●	
<b>Exhaust manifold cracked, gaskets blown or missing</b> Refer to engine manufacturer s manual and replace gaskets or damaged parts as required		●	●	●	●			●			
<b>Gas leak at turbine inlet/exhaust manifold joint</b> Replace gasket or tighten fasteners as required		●	●	●	●			●			
<b>Gas leak in ducting after turbine outlet</b> Refer to engine manufacturer s manual and repair leak		●						●			
<b>Restricted turbocharger oil drain line</b> Remove restriction or replace damaged parts as required						●	●			●	●
<b>Restricted engine crankcase breather</b> Refer to engine manufacturer s manual, clear restriction						●	●			●	●
<b>Turbocharger bearing housing sludged or coked</b> Change engine oil and oil filter, overhaul or replace turbocharger as required						●	●			●	●
<b>Fuel injection pump or fuel injectors incorrectly set</b> Refer to engine manufacturer s manual and replace or adjust faulty components as required		●	●	●	●						
<b>Engine valve timing incorrect</b> Refer to engine manufacturer s manual for correct settings and adjust as required				●	●						
<b>Worn engine piston rings or liners</b> Refer to engine manufacturer s manual and repair as required				●	●	●	●			●	●
<b>Burnt valves and/or pistons</b> Refer to engine manufacturer s manual and repair as required				●	●	●	●			●	●
<b>Excessive dirt build up on compressor wheel and/or diffuser vanes</b> Clean in accordance with details in the appropriate Holset publication				●	●	●	●	●	●	●	●
<b>Turbocharger damaged</b> Find and correct cause of failure, repair or replace turbocharger as necessary				●	●	●	●	●		●	●
<b>Failed actuator diaphragm</b> Replace using correct Actuator Service Kit	●							●			
<b>Seized wastegate valve (in turbine housing)</b> Free valve in accordance with details in the appropriate Holset publication replace complete turbine housing sub-assembly	●	●									
<b>Leaking actuator hose</b> Replace hose and clips	●							●			
<b>Wastegate mechanism set incorrectly</b> Contact your approved Holset agent for correct setting procedure	●	●	●	●				●			

# Service Tools



The following special tools are recommended to perform procedures in this manual. The use of these tools is shown in the appropriate procedure.

Part No.	Tool Description	Tool Illustration
	Torque Wrench	
	Dial Gauge and Dial Gauge Adaptor	
3575186	Circlip Pliers	
	Pressure Gauge Regulated Air Supply (Max 3 bar-45 lbf/in <sup>2</sup> )	
4027202	Air Supply Adaptor	
4027203	Air Supply Adaptor	
4027204	E-Clip Tool	

**Caution** All Service and Maintenance settings are shown in Holset's Service Data Sheet. It is essential that these settings are used. Common tools found in mechanic's tool box not included.

# On Engine Checks



## Oil Leakage

Bearing Housing M12 x 1.5 (19 mm)  
Pipe Fitting 11/16-16 UN (19 mm)

**Warning** The oil inlet is pressurised and no service action should be taken with the engine running.

Replacement seals and adapters should be fitted without sealant as this can contaminate the oil. Torque tighten adaptor to value shown in [Service Data Sheet](#).

It is important to avoid kinked pipes during servicing and subsequent operation.

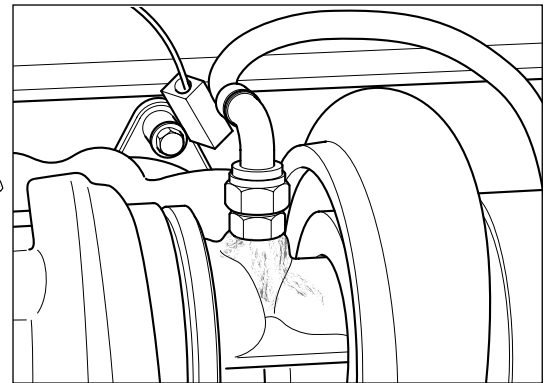

M8 x 1.25

**Warning** Outlet oil is hot and no service action should be taken with the engine running.

Replacement gaskets and flange fasteners should be fitted without sealant as this can contaminate the oil. Torque tighten fasteners to value specified by engine manufacturer.

All outlet pipes should be free flowing without kinks and sharp bends and decline at an overall angle not less than 30° below the horizontal.

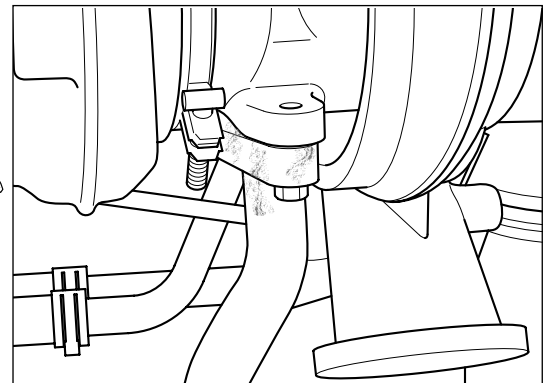

Closed crankcase ventilation systems may deposit oil in the compressor housing. Where practical remove intake system pipework every 50,000 km (30,000 miles) to check housing, compressor wheel and inlet baffle condition.

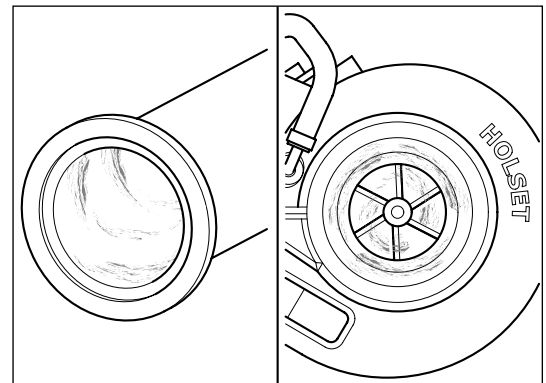

Always refer to [Cleaning of Housings](#) to clean housing. Rotor components can be cleaned using a non-metallic bristle brush

**Warning** Always wear safety glasses during cleaning.

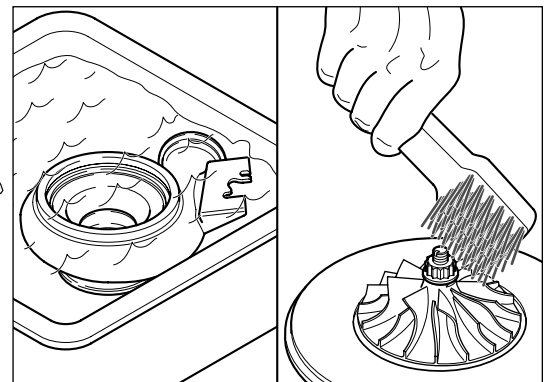





### Gas Leakage

Turbine housing flange leakage will cause soot formation on the flange. Check exhaust manifold to flange seal ensuring fastener torque meets engine manufacturer's recommendation.

Check flange for cracks.

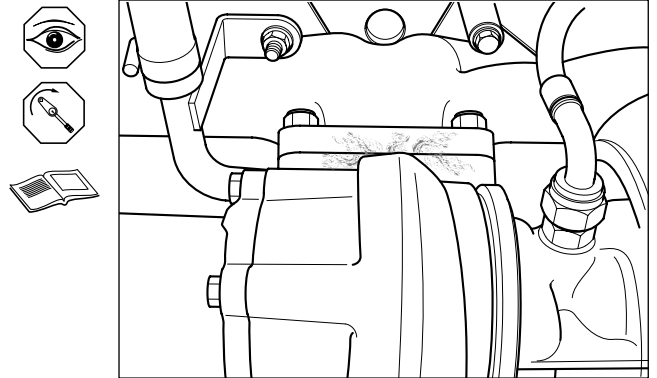

Where practical remove exhaust system pipework to check cover plate flange sealing face for cracking and distortion. Check exhaust system connecting profile for fretting damage.

If sealing is compromised replace cover plate if available ensuring fastener torque meets engine manufacturer's recommendation.

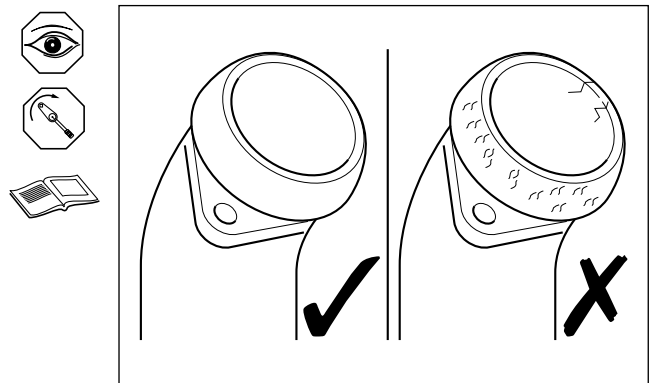

### Visual Checks

Check for cracked, bent or damaged compressor wheel blades.

**Caution**  Never attempt to straighten blades.

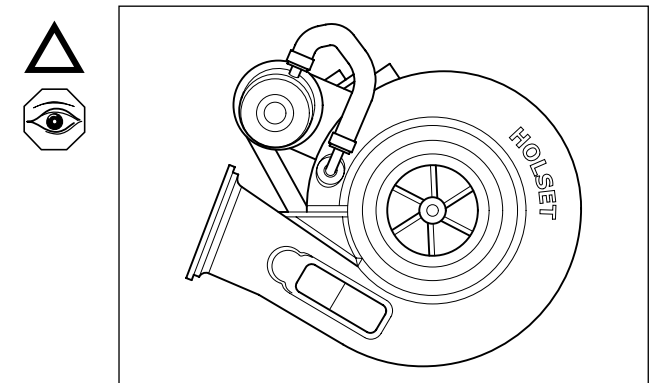

Where practical, check for cracked, bent or damaged turbine wheel blades. This will require cover plate removal where fitted.

**Caution**  Never attempt to straighten blades.

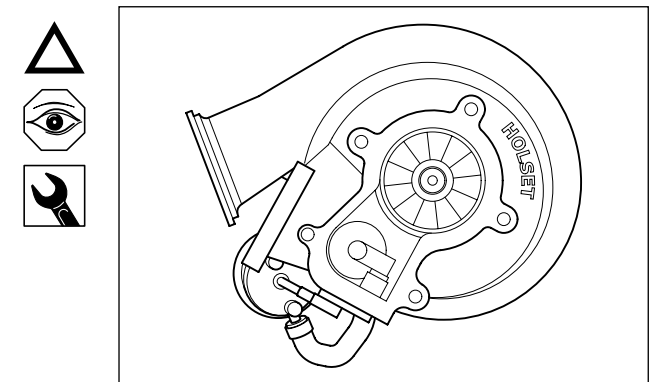



With intake system disconnected from compressor housing, it may be possible to check visually for excess bearing axial and radial clearances.

If in doubt, the turbocharger must be removed from engine to check bearing clearance against recommended values shown in [Service Data Sheet](#).

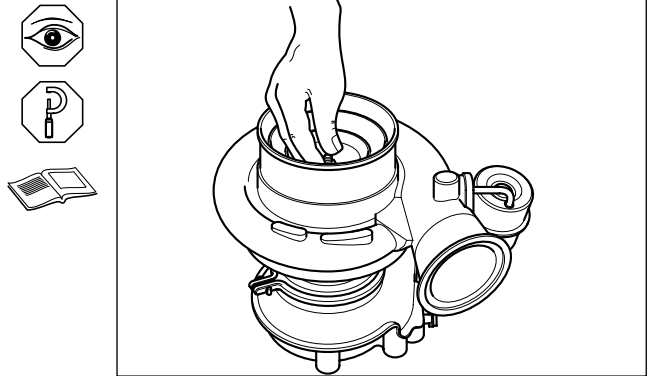

If it is possible to check for wastegate actuator rod movement and air leakage on engine, follow the checking procedure described later in [Wastegate Actuator Checks](#).

**Warning**  Never attempt to check actuator using air supplied from a running engine.

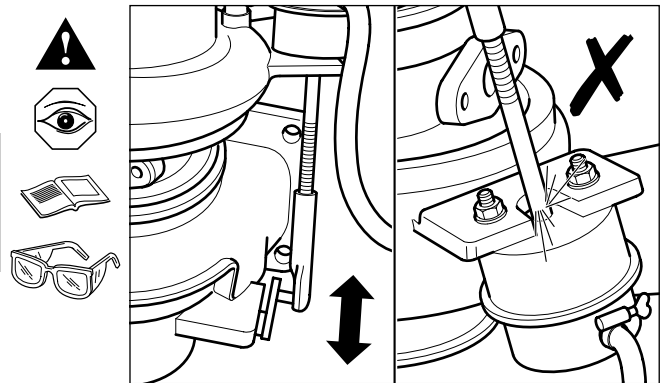

## Bearing Clearance



Secure the turbine housing and check the axial clearance using a dial gauge.

Ensure clearance is within MIN/MAX values shown on [Service Data Sheet](#).

If axial clearance does not meet specification refer to turbocharger [Service and Overhaul](#) to strip and rebuild the CHRA (core).

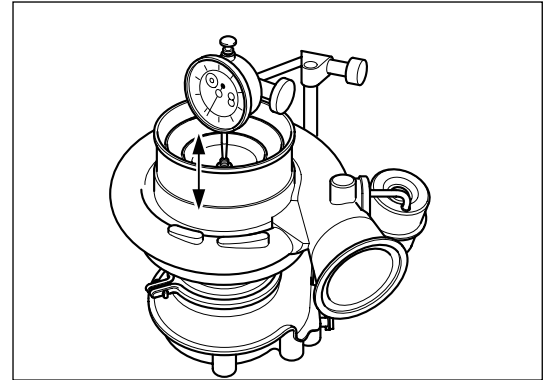

Check the radial movement at compressor impeller nose using a dial gauge.

Ensure movement is within MIN/MAX TIR (Total Indicator Reading) values shown on [Service Data Sheet](#).

If radial movement does not meet specification refer to turbocharger [Service and Overhaul](#) to strip and rebuild the CHRA (core).

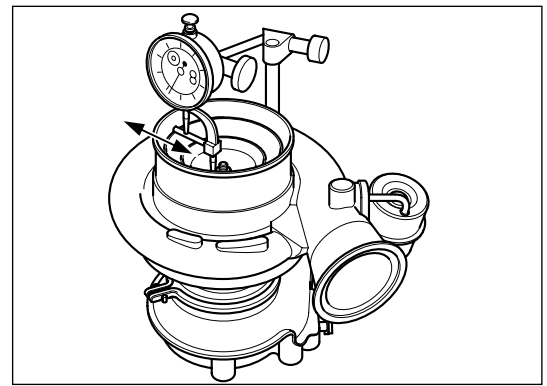

# Turbine and Compressor Housings



**Note**  
 Before removing turbine or compressor housings it is necessary to remove wastegate actuator. Always ensure the end link is locked in the correct pre-set position before removal.

Remove e-clip and actuator fasteners. Then remove actuator from turbocharger. Do not adjust the rod end link.

Refer to [Actuator Removal](#) for details of removal procedure.

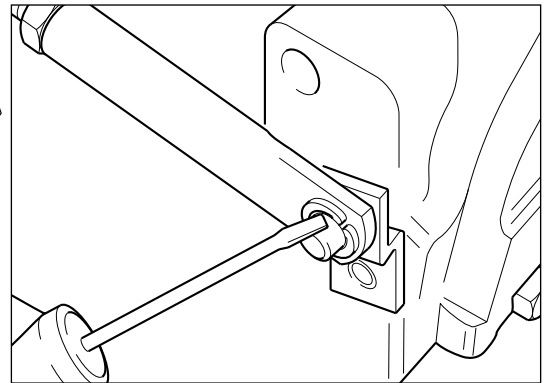

**Caution**   
 Do not rotate actuator rod relative to actuator as this can damage actuator internal components.

## Turbine Housing

**Note**  
 Turbine housing option with cover plate fitted can be removed without removing the cover plate.

Place compressor cover face on a flat surface. Mark turbine housing, bearing housing and V-band clamp to record correct orientation. This action assists in re-assembling the pinned components and defines clamp orientation.

M6 (10 mm)

Loosen V-band clamp locknut (62) and discard.

**Caution**   
 The locknut has a self-locking feature. It must be replaced every time it is removed to ensure long term clamp loading of the V-band.

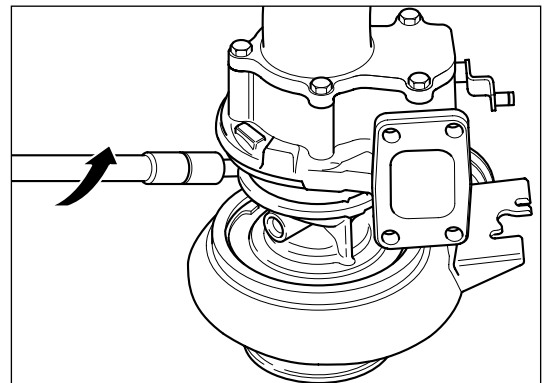
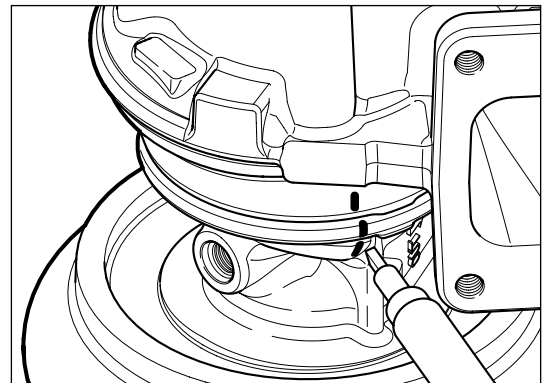

**Caution**   
 Turbine blades can be damaged easily when the turbine housing is removed. Do not bend the locating pin that aligns bearing housing and turbine housing.

Gently remove turbine housing assembly and V-band clamp.

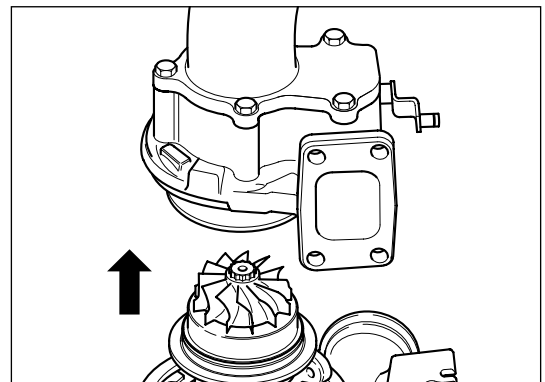





**Caution**   
 Turbine housings can exhibit cracking when subject to excessive thermal and mechanical loads.

Cracking of the turbine housing inlet flange and inlet duct generally requires turbine housing replacement. Acceptance and rejection guidelines are shown in this illustration. If an exhaust gasket is available, always ensure that any cracks lie within its sealing area.

Check turbine housing inlet flange flatness is within 0.1 mm (0.004 in) before retaining component for re-use.

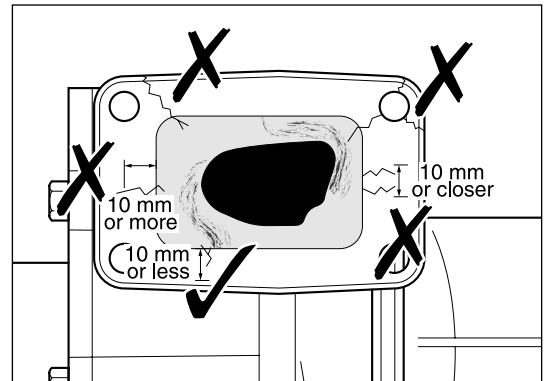
Check fastener hole diameter is not more than 1.5 mm larger than the max. thread diameter of the fastener.



**Caution**   
 Where a crack will cause leakage to atmosphere the turbine housing must be replaced.

Cracking of the internal wall at the entry to the turbine wheel (tongue) is an acceptable service condition and the turbine housing may be re-used.

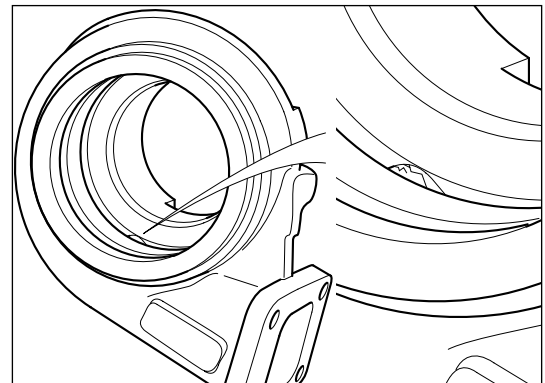

To replace turbine housing position V-band clamp over the bearing housing and align indelible ink marks applied during disassembly.

Apply high temperature anti seize compound to bearing housing locating bore of the turbine housing.

Carefully slide the turbine housing onto the CHRA. Use ink alignment mark to locate assembly on to the dowel pin fixed into the bearing housing.

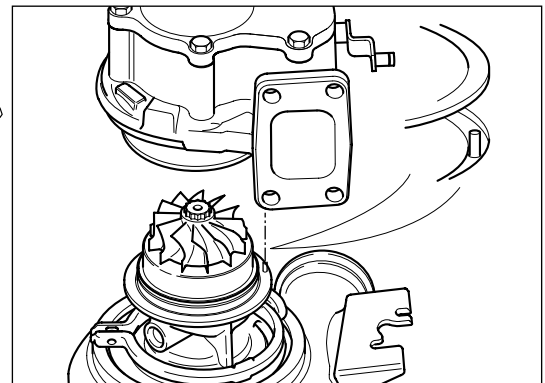

**Caution**   
 The turbine wheel blades can be easily damaged when the turbine housing is installed.

M6 (10 mm)  
 Place V-band clamp in position and torque tighten new locknut to value specified in [Service Data Sheet](#).  
 Ensure rotor assembly freely rotates.

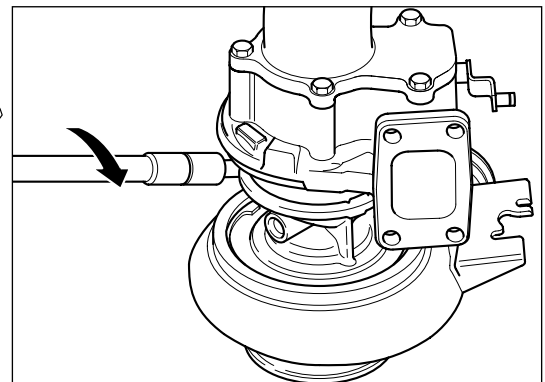
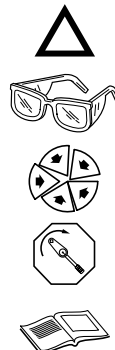

**Caution**   
 Be careful not to bend the location pin during assembly.



## Compressor Housing

### Note

It is necessary to remove wastegate actuator before removing compressor housing. Always refer to [Actuator Removal](#) before proceeding with housing removal.

Mark compressor housing, bearing housing and retaining ring to record correct orientation. This action assists in re-assembling the pinned components and defines orientation of the retaining ring.

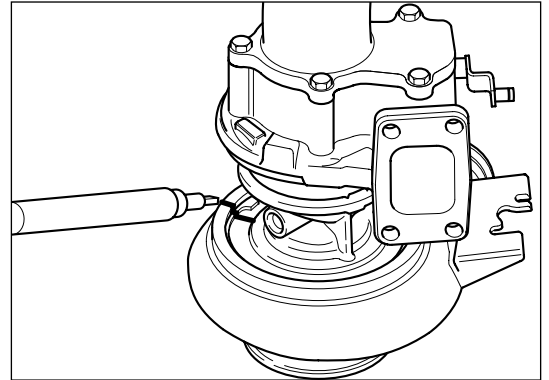

### Warning

Always wear safety glasses when removing retaining ring.

Remove compressor cover retaining ring using circlip pliers part no. 3575186.

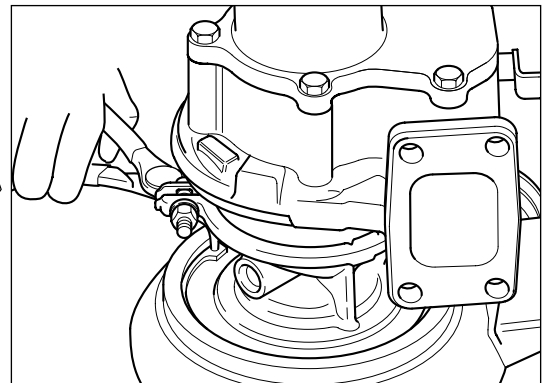

### Caution

Compressor blades can be damaged easily when the compressor housing is removed. Do not bend the locating pin that aligns bearing housing and compressor housing.

Using a soft hammer, gently tap the compressor housing off the bearing housing.

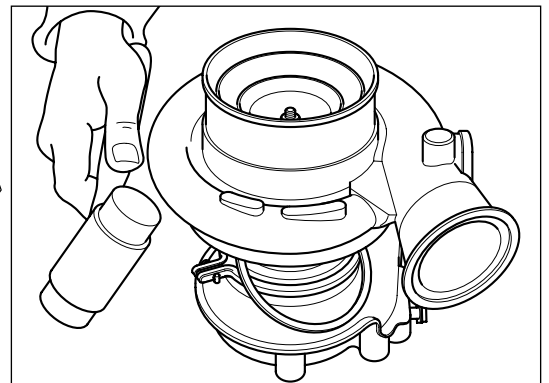

On some turbocharger options, the bearing housing to compressor housing joint is fitted with O-ring seal, compressor (41). This seal should be removed and discarded at this stage.

### Caution

Always fit a new seal on reassembly.

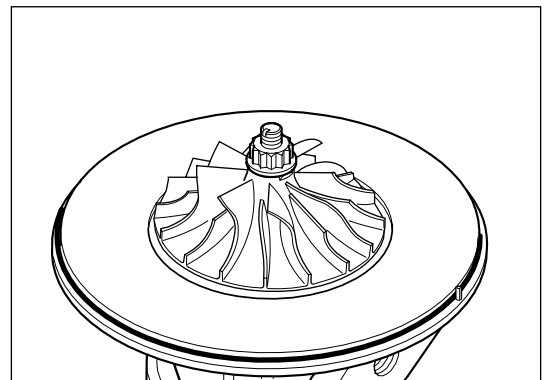





Inspect internal profile of compressor housing for scoring damage due to possible contact with compressor wheel. Check compressor housing retaining ring groove is free from deposits and is not worn.

Move to **Cleaning of Housings** if deposits remain.

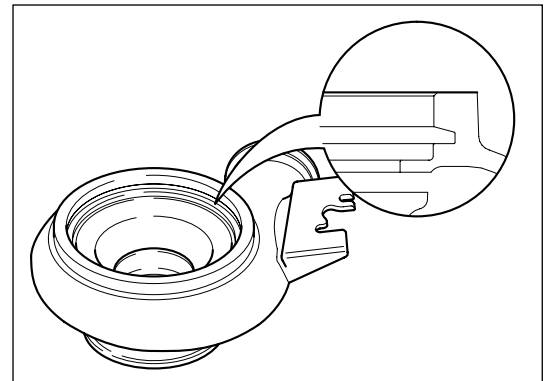
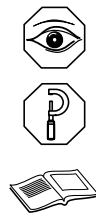
Replace with new if profile damage is visible.



**Caution**  Good groove and abutment face condition are critical to the integrity of compressor housing to bearing housing joint.

To refit compressor housing place the housing (8) on clean surface. Carefully slide the CHRA (2) assembly into the compressor housing. Use alignment marks to locate assembly on to the dowel pin fixed into the bearing housing.

**Caution**  The compressor wheel blades can be easily damaged when the CHRA is installed.

**Caution**  Be careful not to bend the location pin during assembly.

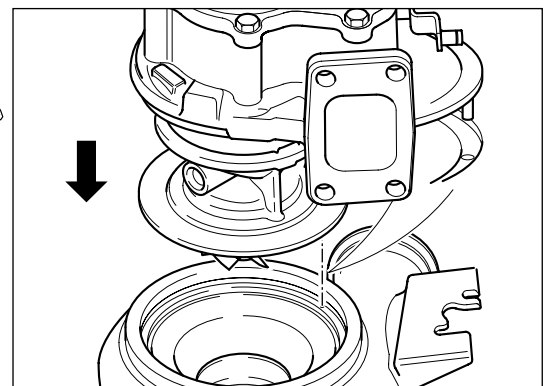

Locate retaining ring over CHRA. Using circlip pliers, part no. 3575186, fit the retaining ring.

**Caution**  The retaining ring must be fitted with the chamfered face upwards away from the compressor housing.

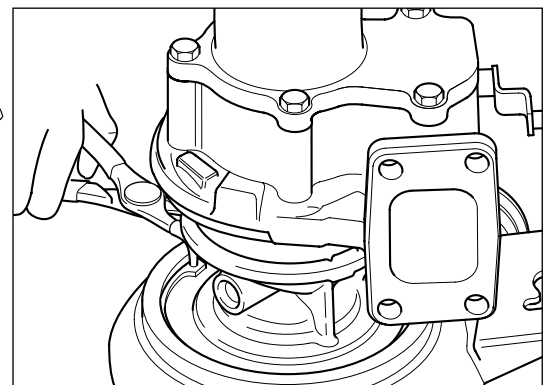

Tap ends of retaining ring lightly with hammer and drift to ensure that the retaining ring is properly located into its groove in the bearing housing.

**Caution**  Ensure that drift does not damage bearing housing during this operation.

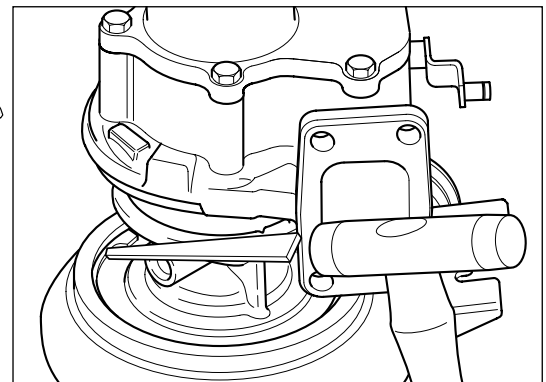



# Cleaning of Housings

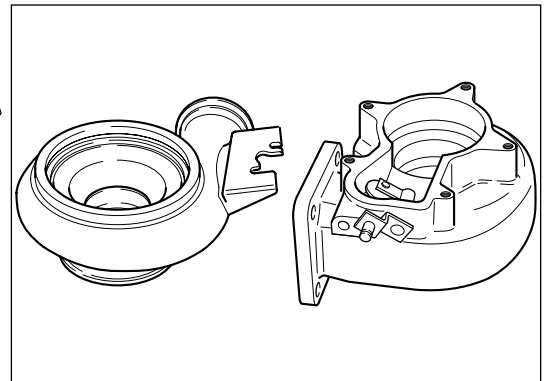

Visually inspect the parts to detect signs of burning and other conditions in order to obtain as much information as possible before washing.

**Caution**  Surfaces adjacent to turbine and compressor wheels on the stationary housings must be clean, smooth and free from deposits.



**Warning**  Always wear safety glasses during cleaning.

Soak the housings in a non-corrosive low flash point metal cleaner to loosen deposits.

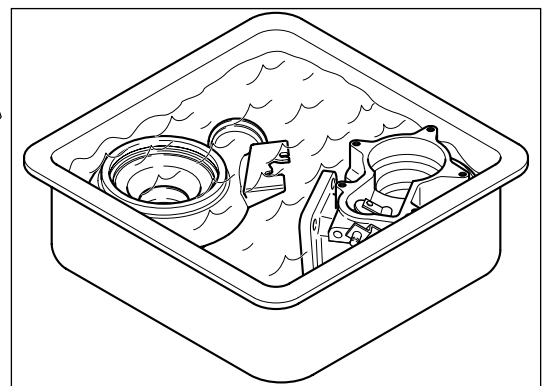

Dry the components using compressed air.

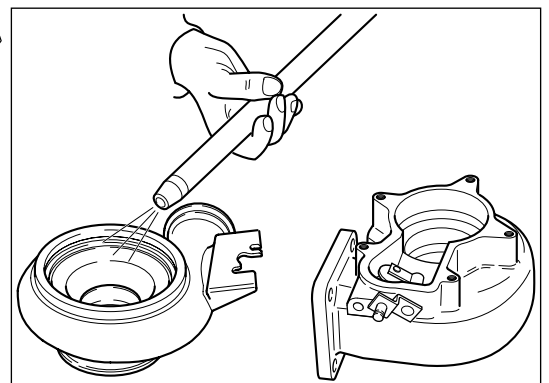
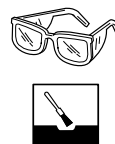

Scale like deposits, if any, must be removed by using a non-metallic bristle brush. After removing the deposits, re-wash and dry the components.

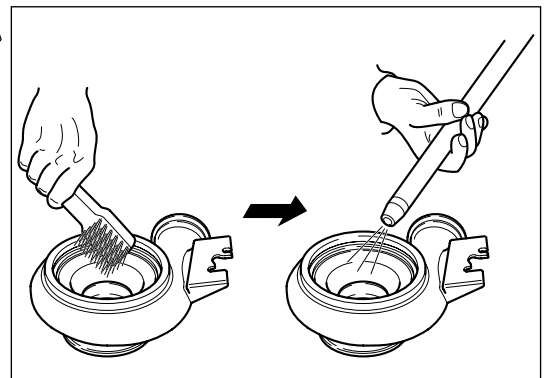





It is permissible to bead blast the turbine housing if chemical and brush cleaning is not effective.

**Warning** 

Do not bead blast Aluminium and Cast Iron components together.

**Caution** 

Prevent the bead spray hitting the wastegate valve spindle as beads can penetrate the spindle bore leading to spindle seizure.

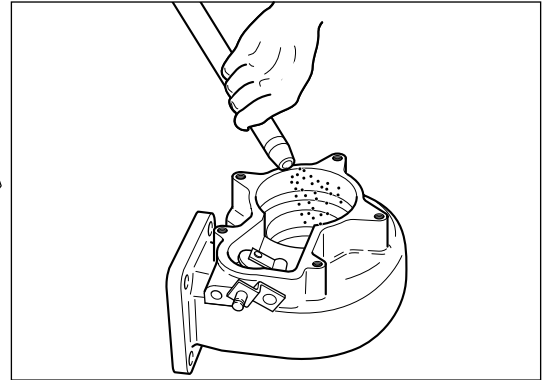



After removing the deposits, re-wash and dry the components.

# Wastegate Actuator Checks



## Actuator Hose Feed Check

**Caution**  Do not remove turbocharger from engine unless an actuator check is impractical due to space or access limitations or where an on-engine check has shown a problem exists.

**Warning**  Wear safety glasses at all times during the disassembly process.

Place the turbocharger on a suitable workbench. Using a small flat screwdriver, carefully remove the hose clip. Pull the flexible hose from the actuator spigot.

Discard the hose clips (75).

Connect and secure the hose from the regulated compressed air supply to the actuator spigot.

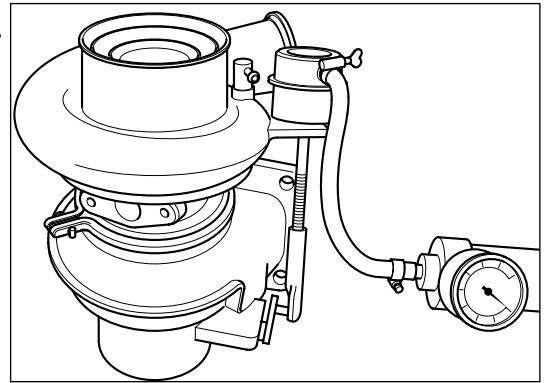
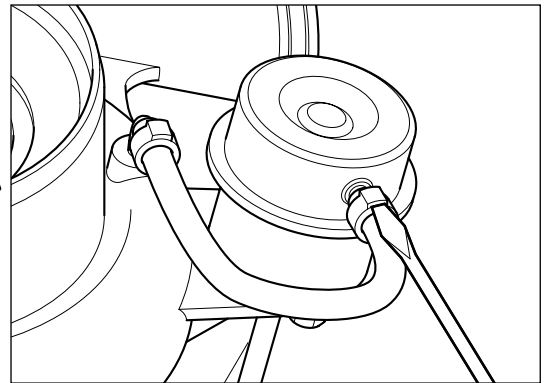

**Warning**  Avoid touching the wastegate rod end area as finger injury may result from sudden movement of the assembly when air pressure is applied.

Carefully apply pressure to the actuator from the regulated compressed air supply (Max 3 bar, 45 lbf/in<sup>2</sup>) and check for actuator movement.

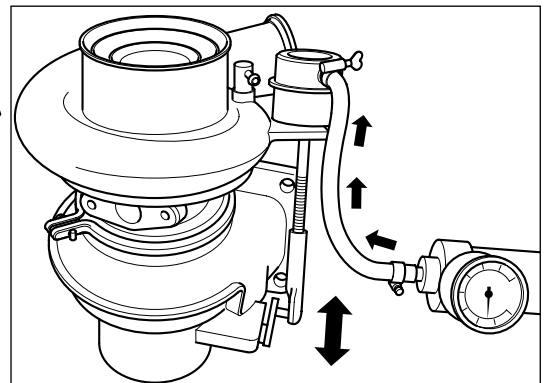

## Seized Actuator Check

If rod does not move check wastegate actuator for air leaks. If no air leak is found and rod does not move, check valve mechanism for seizure according to the procedure in [Wastegate Mechanism Check](#).

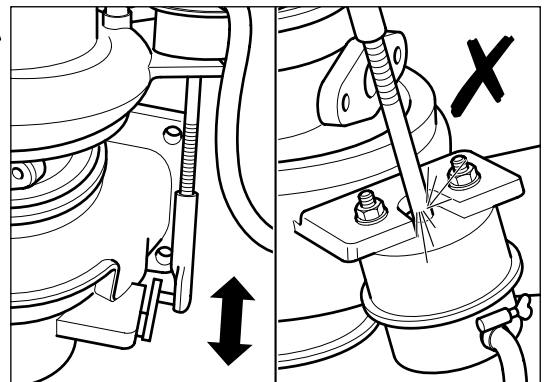



### Actuator Integrated Feed Check

**Caution**

Do not remove turbocharger from engine unless an actuator check is impractical due to space or access limitations or where an on-engine check has shown a problem exists.

**Warning**

Wear safety glasses at all times during the disassembly process.

Fit air supply adaptor Part No. 4027202/3 to make a pressure tight seal with the compressor housing internal seating.

Connect and secure the hose from the regulated compressed air supply to air supply adaptor inlet spigot.

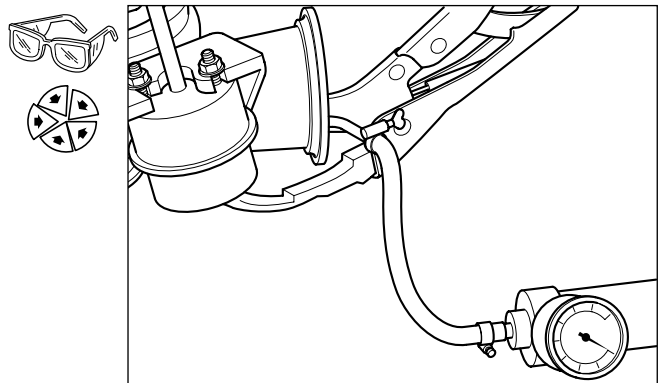
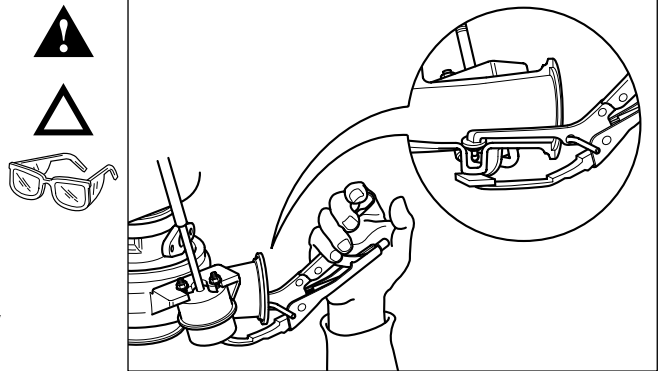

**Warning**

Avoid touching the wastegate rod end area as finger injury may result from sudden movement of the assembly when air pressure is applied.

Carefully apply pressure to the actuator from the regulated compressed air supply (Max. 3 bar, 45 lbf/in<sup>2</sup>) and check for actuator movement.

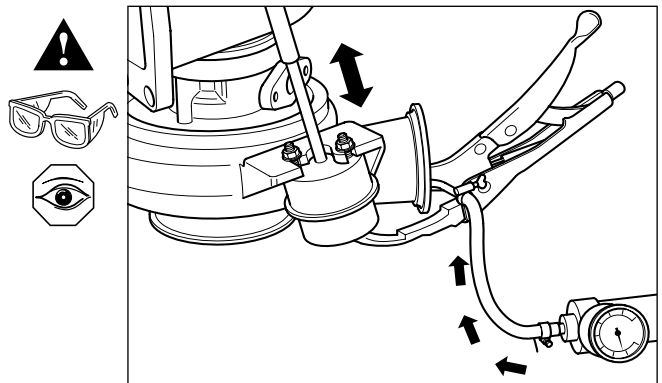

### Seized Actuator Check

Check for rod movement. If rod does not move check wastegate actuator for air leaks. If no air leak is found and rod does not move, check valve mechanism for seizure.

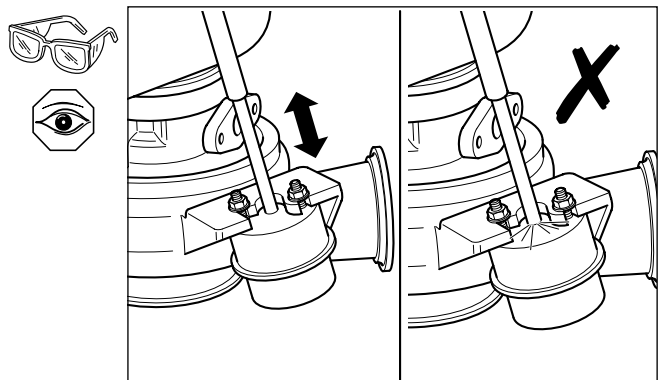

# Actuator Removal



**Warning**   
 Wear safety glasses at all times during the disassembly process.

Using a small flat screwdriver, carefully remove the end link retaining clip.

**Caution**   
 Do not rotate actuator rod relative to actuator as this can damage actuator internal components.

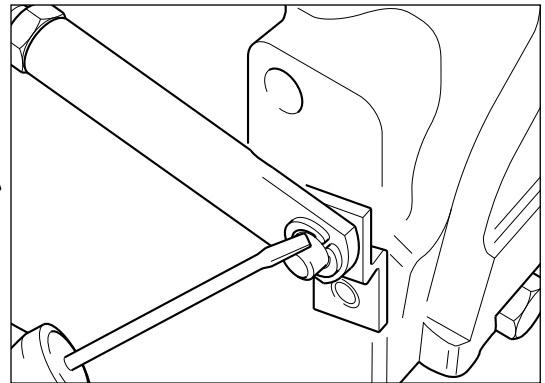
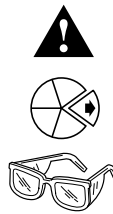

**Warning**   
 The rod may retract very quickly when freed from lever arm. Keep fingers away from mechanism.

Gently apply a small amount of air to the actuator and when/if the rod end moves, carefully slide the link end off the valve lever arm. If the actuator rod does not move, a screw driver may be required to prise the link end off the lever arm.

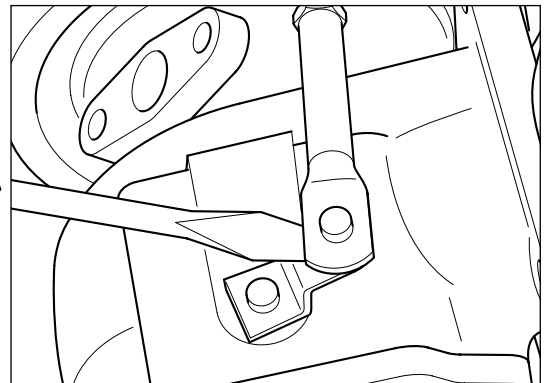
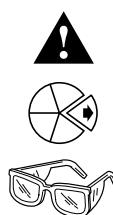

M6 (10 mm)

Remove actuator lock nuts.

**Caution**   
 Do not adjust the rod end link. This setting is critical to actuator performance.

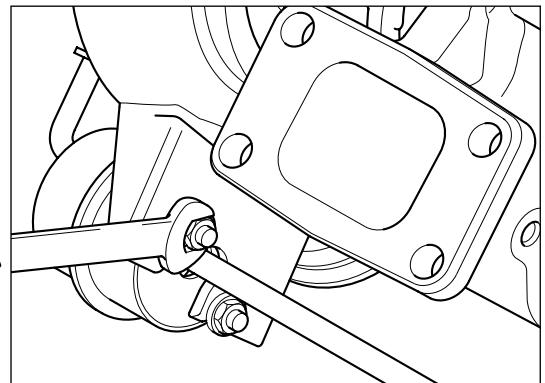
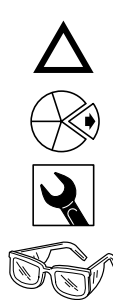

## Integrated feed option

Draw wastegate integrated feed away from compressor housing location by sliding actuator studs out of slotted locations on bracket.

**Caution**   
 Ensure wastegate valve mechanism and actuator rod is not damaged during disassembly.

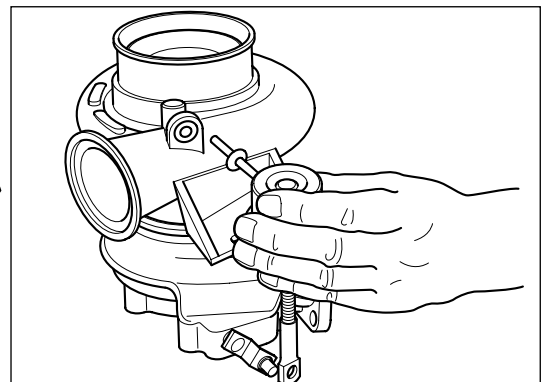
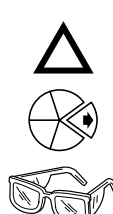



Remove "O" ring seal from compressor housing location.

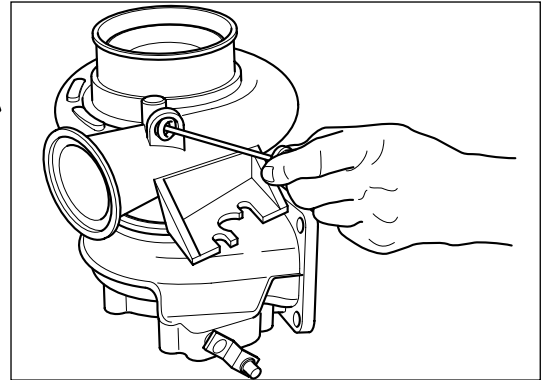

Replace "O" ring seal on actuator air inlet spigot.

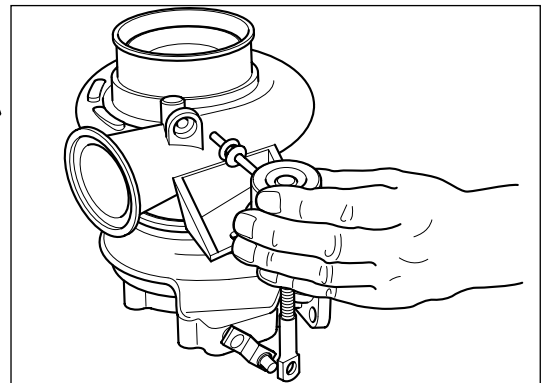

**Hose feed option**

After removal of hose clip and hose, lift the actuator away from the bracket until the studs clear the location holes.

Discard hose clips (75).

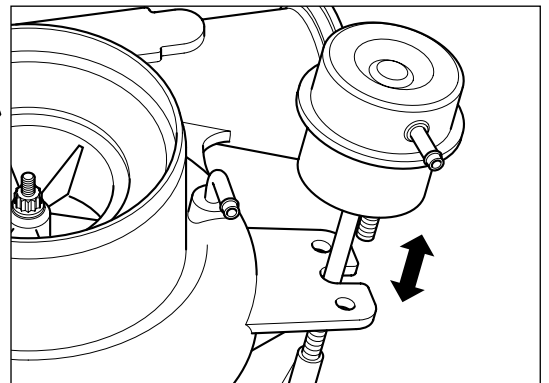

# Wastegate Mechanism Check



Carefully move the lever arm up and down. If the arm moves freely by hand, then re-check for movement of actuator rod.

Apply an air pressure of 3 bar, 45 lbf/in<sup>2</sup> to the actuator spigot inlet. If the rod does not move, replace the actuator with a pre-set replacement kit. (74)

If the lever arm is seized, the turbine housing will require replacement. However, it may be possible to free the lever arm.

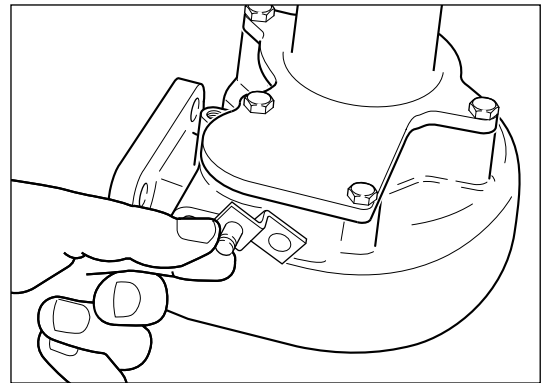

M8 (13 mm)

**Caution** Take care not to shear the 5 coverplate bolts.

Remove cover plate option.

Seized bolts may be freed by spraying with penetrating oil and soaking for 20 minutes or a period of time recommended by the oil manufacturer.

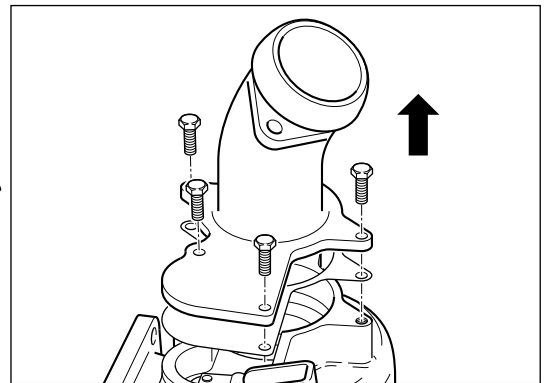
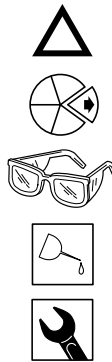

Soak wastegate valve and lever mechanism in penetrating oil.

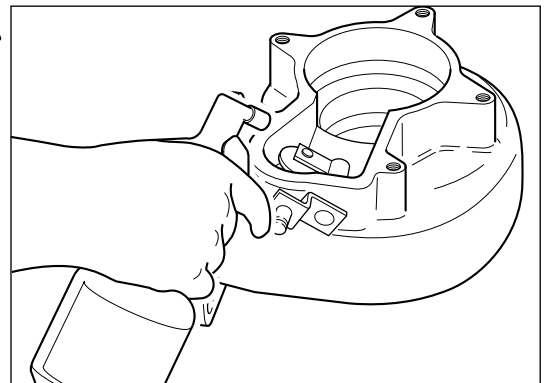

Some turbine housing options do not have open access to the wastegate valve but, with care, soaking with penetrating oil may still be possible.

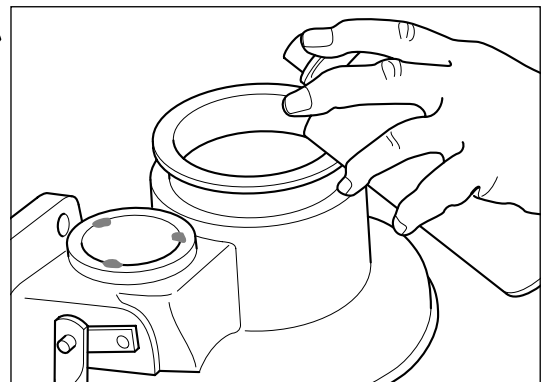



**Caution**  Extra care must be taken when attempting to free the valve mechanism. Any damage will result in the replacement of the turbine housing.

Clamp a pair of quality mole (vice) grips to the lever and gently apply pressure to rotate the lever arm in an arc.  
If this process does not free the valve mechanism, a new turbine housing must be fitted.

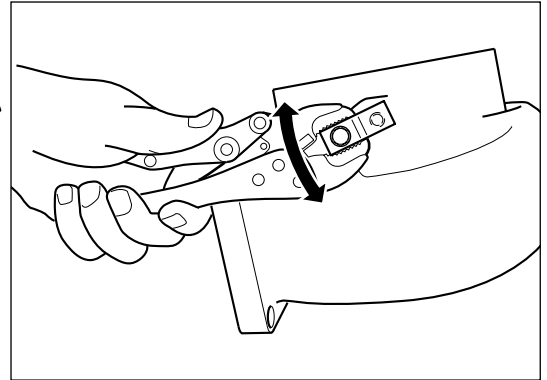

**Caution**  If the wastegate valve mechanism shows any fault, it must be replaced. Using damaged turbine housings will lead to inferior performance of the turbocharger, and risk of irreparable damage to both turbocharger and engine.

Radial cracks can occur around the valve seat when the turbocharger has been abused or overheated.

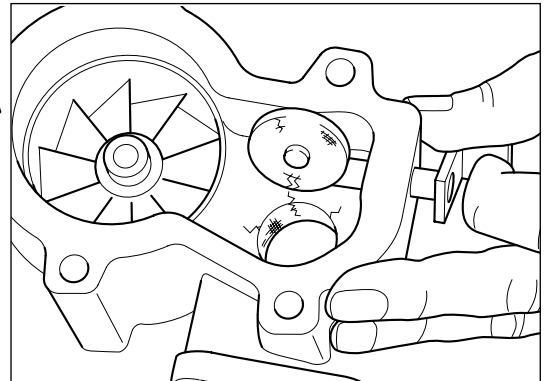

Lever arm pin can be worn by partial seizure of the valve mechanism. Scoring may be caused by arduous local environmental conditions.

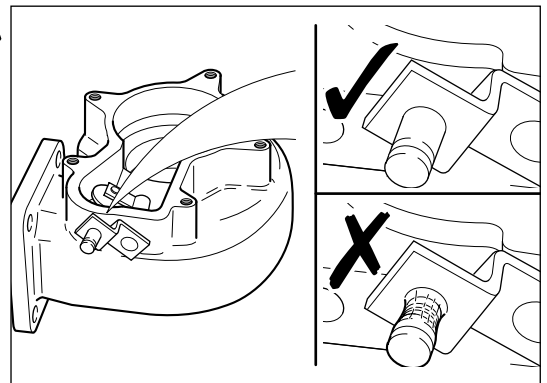

The same failure conditions can also lead to elongation of the rod end bore which locates on the lever arm pin. This must not exceed 0.50 mm (0.020 in).

**Caution**  If the wastegate shows any fault, it must be replaced.

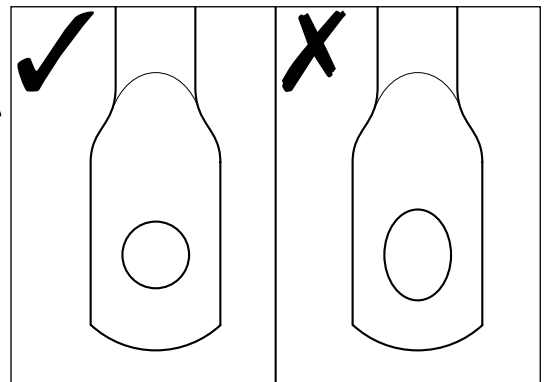

# Wastegate Actuator Replacement



**Caution**  Contact your local approved agent for the correct replacement actuator kit (74). It is important to quote the correct turbocharger assembly number, serial number and type from the dataplate to ensure the supply of the correct pre-set actuator.

**Note** When refitting existing actuator the end link will be locked in the correct setting.

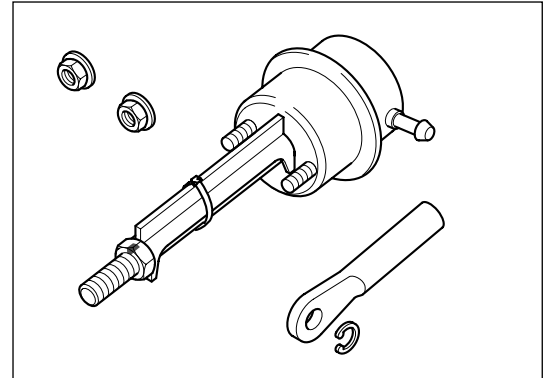

Thread new end link several turns on to the shaft of the new pre-set actuator assembly.

Hold the actuator assembly with the spine of the spacer piece upright. Rotate the valve mechanism lever arm to close the wastegate valve (pushed towards the compressor end). Fit end link over the lever arm pin.

Attempt to slide the actuator over its retaining bracket. If the actuator fouls on the bracket or there is significant clearance between bracket and actuator base, actuator rod length requires adjustment.

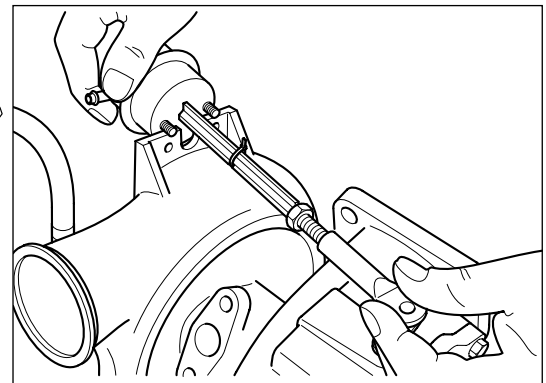

**Note** Do not fit the wastegate studs to the bracket at this stage.

To adjust the length of the actuator assembly, remove from the turbocharger. Rotate the end link to shorten or lengthen the rod as appropriate. Re-fit, until the underside of the actuator will just fit over the bracket mounting face with less than 0.5 mm (0.020 in) gap.

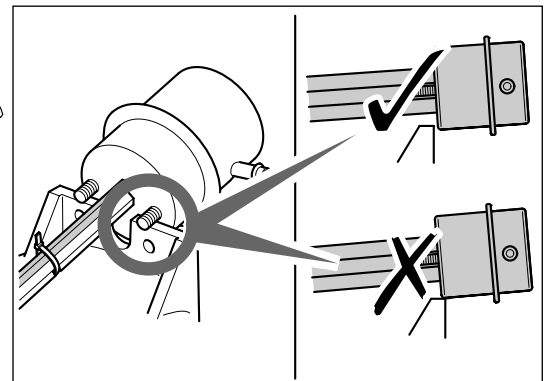

**Caution**  Do not apply force to push the actuator on to the mounting face of the bracket.

The rod length setting is correct if, by rotating end link clockwise by a half turn, the actuator body fouls on the bracket.

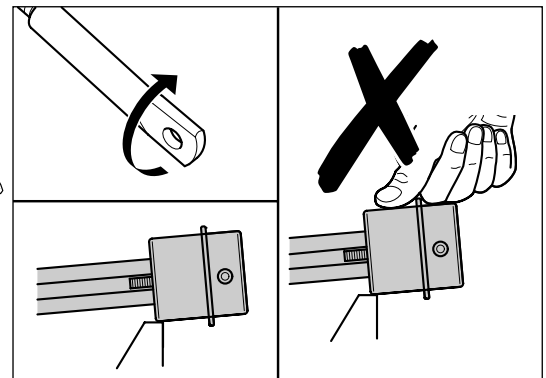





1/4 - 28 UNF 2B (7/16 in)

Remove the actuator assembly from the lever arm ensuring that the end-link does not rotate. Fit actuator mounting studs into their locating holes (or slots) in the bracket. Fit both actuator mounting nuts and torque tighten to the value shown in the [Service Data Sheet](#).

**Caution** Ensure wastegate with integrated feed is properly fitted to compressor housing with o-ring seal.

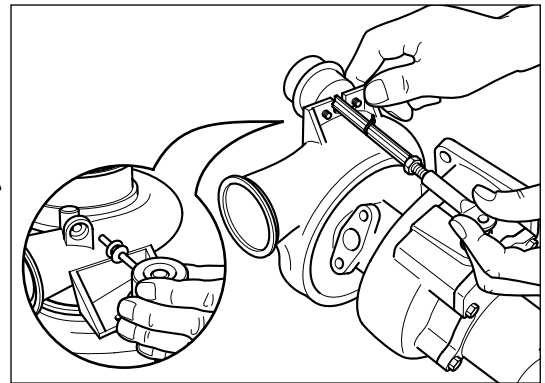

Re-fit end link to the lever arm pivot pin. Fit new e-clip using special tool Part No. 4027204 to retain rod end on pin.

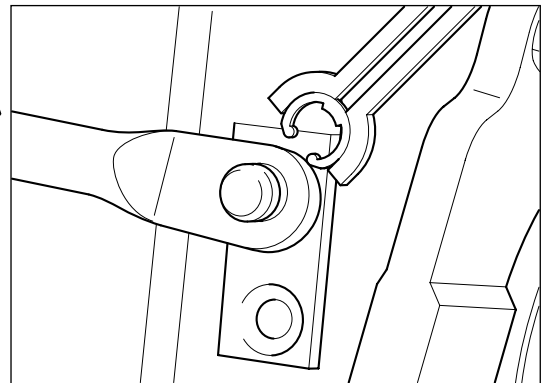

5/16 - 24 UNF 2B (1/2 in)

Loosen spacer piece by turning jam-nut anti-clockwise (counter-clockwise). Remove and discard tie wrap and spacer piece.

Continue turning jam-nut in the same direction, and torque tighten against end link to value shown in [Service Data Sheet](#).

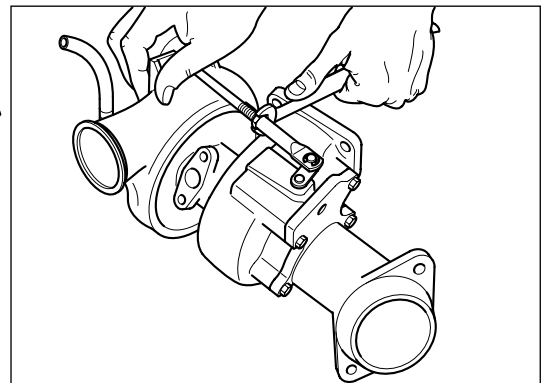

New pre-set actuator kits (74) may be supplied with a tamper resistant break off nut (143) instead of a jam nut (128) to secure the end link in its correct pre-set position. To install a tamper resistant actuator

1. Slacken the shear nut from the spacer spine
2. Continue to turn the nut until it contacts the pre-set end link
3. Continue tightening until the hex flats break off leaving only the cone section in tight contact with the end link.

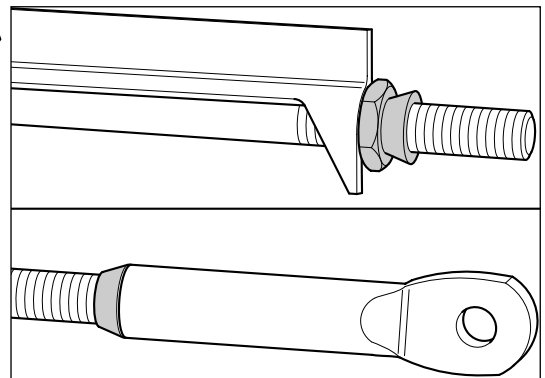
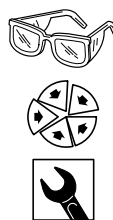



**Caution** 

Before mounting turbocharger on engine, check for full and free wastegate movement, previously described in [Wastegate Actuator Checks](#).

On hose fed actuator options, refit the air supply hose with new clips (75). Clips should be crimped closed using pinners. Crimp gap will vary due to spring back and hose type but will not be less than 0.6 mm (0.0025 in).

Suitable alternative hose clamps can be used.

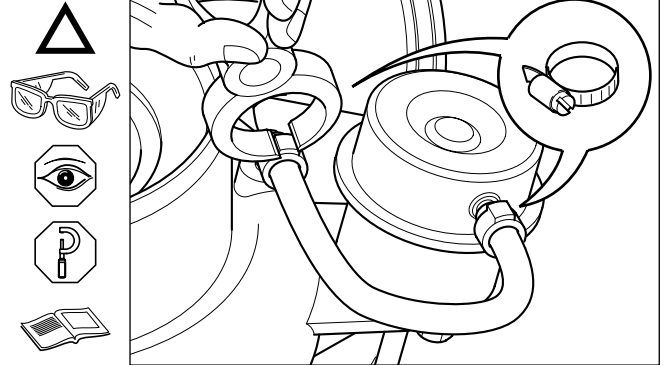

# Service Tools



The following special tools are recommended to perform procedures in this manual. The use of these tools is shown in the appropriate procedure. These tools can be purchased from your local Authorised Repair Location.

Part No.	Tool Description	Tool Illustration
	Torque Wrench	
	Dial Gauge and Dial Gauge Adaptor	
3575186	Circlip Pliers	
56662	Circlip Pliers	
56664	Circlip Pliers	
	Pressure Gauge Regulated Air Supply (Max 3 bar-45 lbf/in <sup>2</sup> )	
4027204	E-Clip Tool	

**Caution** All Service and Maintenance settings are shown in Holset's Service Data Sheet. It is essential that these settings are used. Common tools found in mechanic's tool box not included.

# Disassembly



Locate the CHRA (2) on to a 14 mm 12 point socket located in a suitable fixture.

**Caution**  Always make sure the turbine wheel shaft and compressor wheel have alignment marks before disassembly of the CHRA.

If no marks exist scribe the shaft and compressor wheel before removing the compressor wheel lock nut. The washing process may remove indelible ink so a file mark on the shaft and scribe line on the compressor wheel nose is recommended.

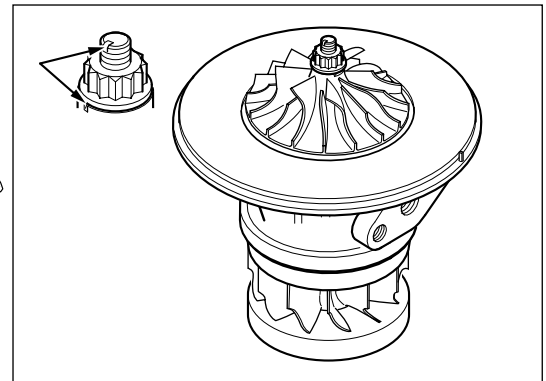
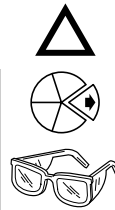

M7 L.H. (10mm)

Remove the locknut, compressor wheel (62).  
(left hand thread).

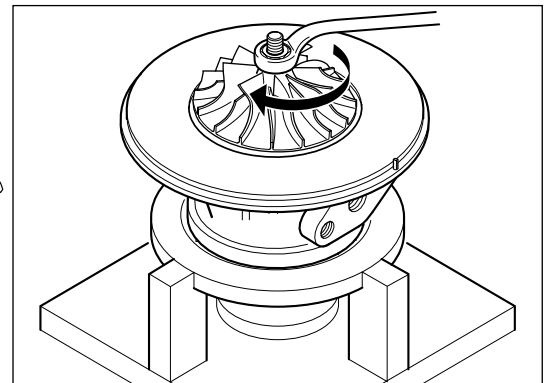
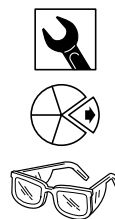

Remove compressor wheel (7).

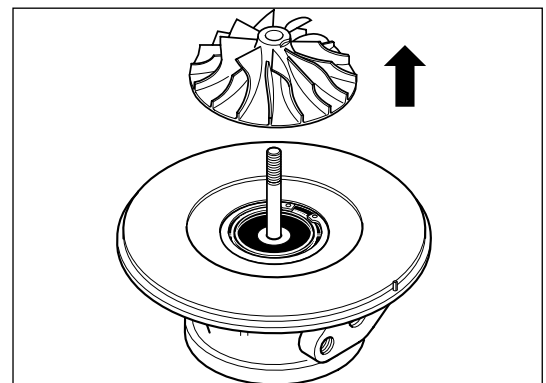

Remove remaining CHRA from fixture and gently slide bearing housing (4) off the assembly turbine wheel (6).

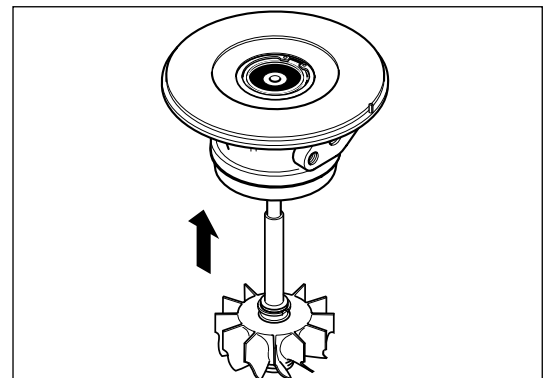



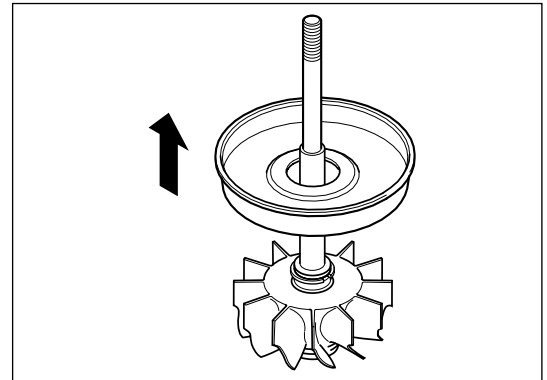

Remove heat shield (38).



Carefully remove and discard the split ring seal, turbine (13) \*.

**Warning**  Eye protection must be used when removing piston rings.

**Caution**  Care should be taken not to score the turbine wheel shaft assembly.

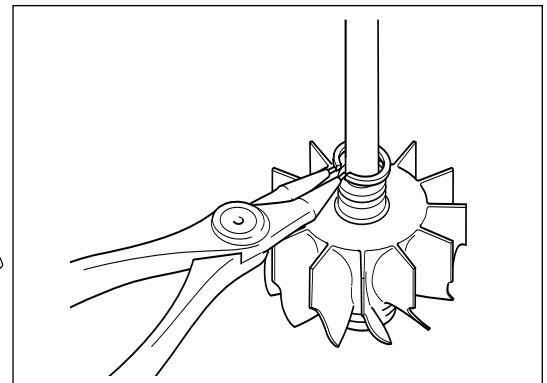

With bearing housing (4) on a flat clean surface, use circlip pliers Part No 56662 to remove insert, retaining ring (66).

**Warning**  Eye protection must be used when removing retaining rings.

It is practical to use free hand to contain disassembled ring whilst releasing pliers.

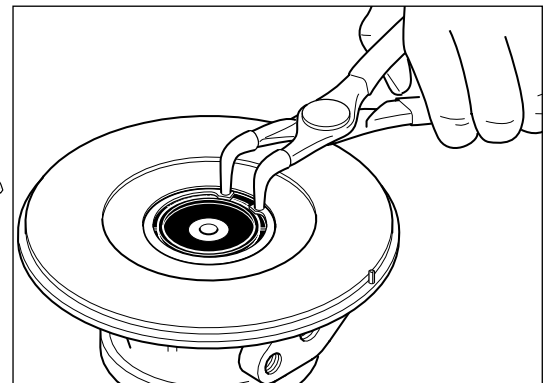

**Note**  
The original specification of HY35W turbocharger was fitted with a plastic oil seal plate. This has been replaced by a steel alternative. Always reassemble the turbocharger with the steel component.

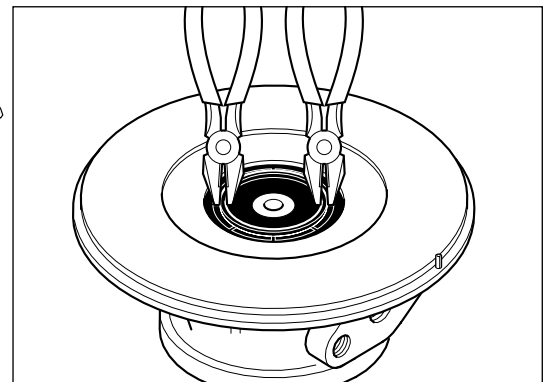

**Plastic oil seal plate**

A straight pull removal of the plastic oil seal plate (43) may be achieved using two flat nose pliers. However, where the plate is stuck in position it may be necessary to use one pliers to lift each side of the seal in turn.



**Steel oil seal plate**

Remove steel oil seal plate (43) using mole (vice) grips.

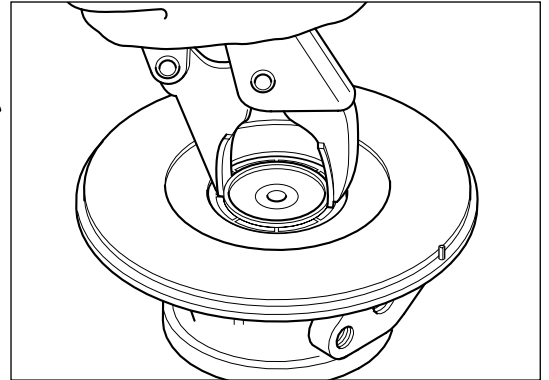

Remove oil slinger (31).

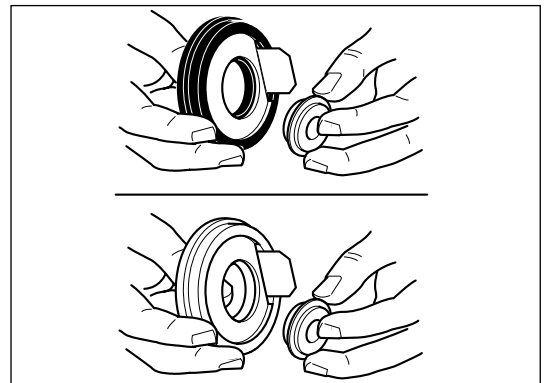

Using piston ring expander pliers remove and discard the split ring seal, compressor (16) \* from oil slinger.

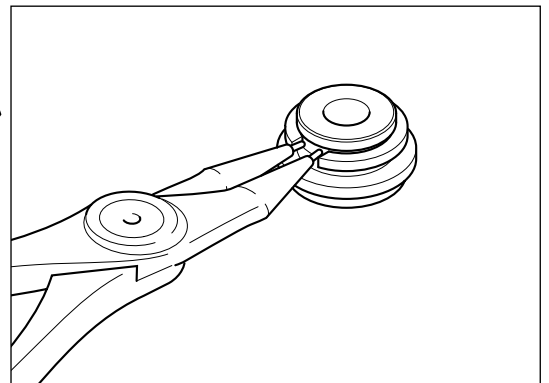

Remove oil baffle (33) \* and discard.

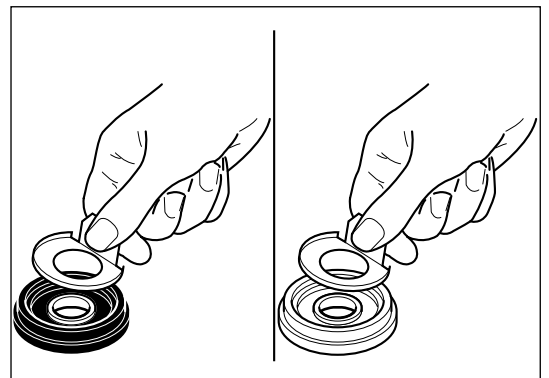



Remove and discard the O-ring seal, bearing housing (32) \*.

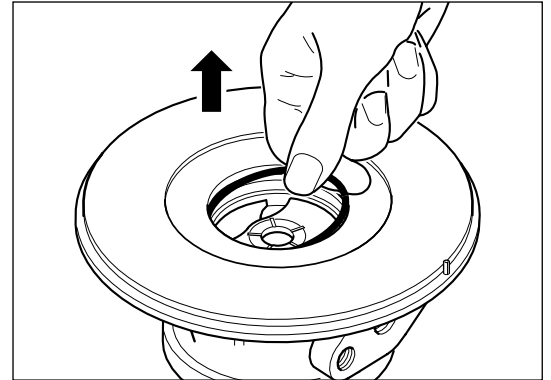

Remove the thrust bearing (12) \* and discard.

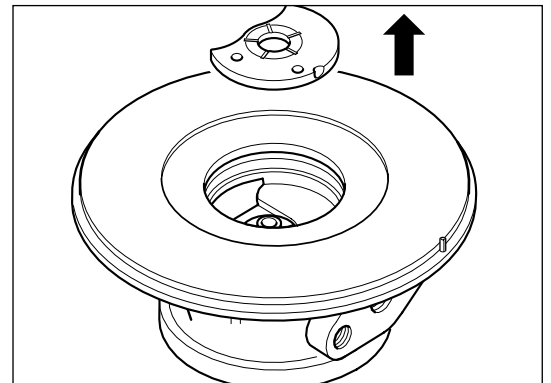

Remove the thrust collar (36).

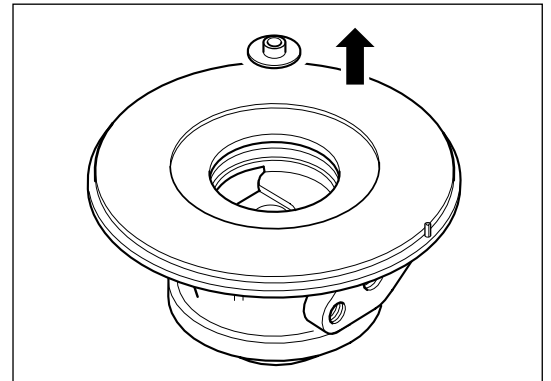

### Circlip Retained Journal Bearings

#### Warning

Always wear safety glasses when removing retaining rings.

Using circlip pliers Part No 56664 remove the two circlips (64) \* and journal bearing (11) \* from the compressor end and discard.

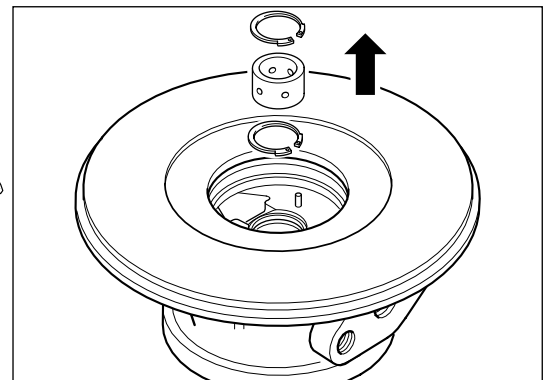



Turn the bearing housing over and repeat the process of retaining ring (64) \* and bearing (11) \* removal at turbine end.

**Warning**  Always wear safety glasses when removing retaining rings.

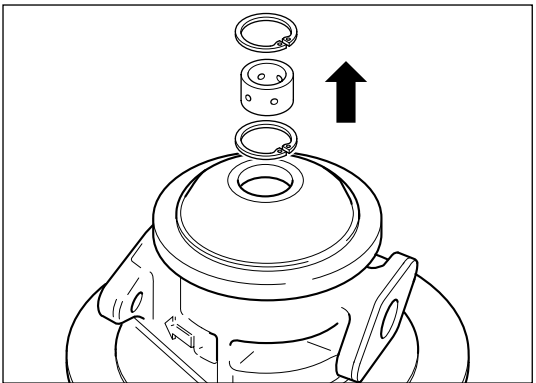
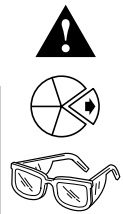

**Spring Separated Journal Bearings**

**Note**  
Some HY35W turbocharger models contain spring separated bearings and bearing housings with no inboard retaining ring grooves. Always retain spring (127) for cleaning and re-use.

Using circlip pliers, Part No. 56664 remove outer retaining ring (64) \* from compressor end and discard.

**Warning**  Always wear safety glasses when removing retaining rings.

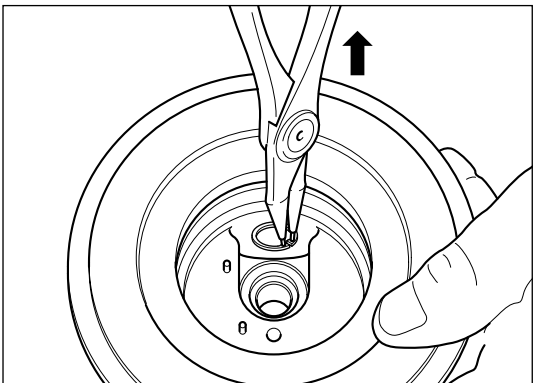

With a finger, remove the journal bearing (11) \* from compressor end and discard.

Repeat removal of retaining ring (64) \* and discard.

With a finger push the spring (127) from the compressor end to force out the bearing (11) \* and discard the bearing.

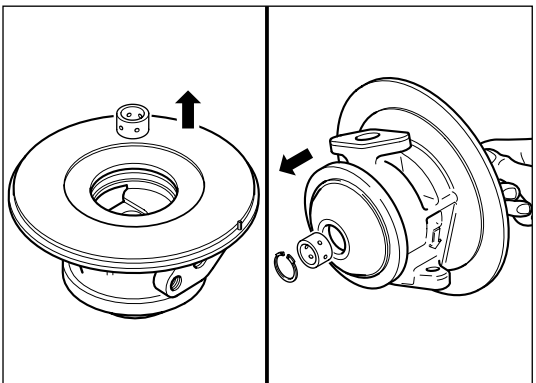
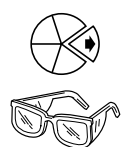

Pull the spring (127) out on a finger from the turbine end.

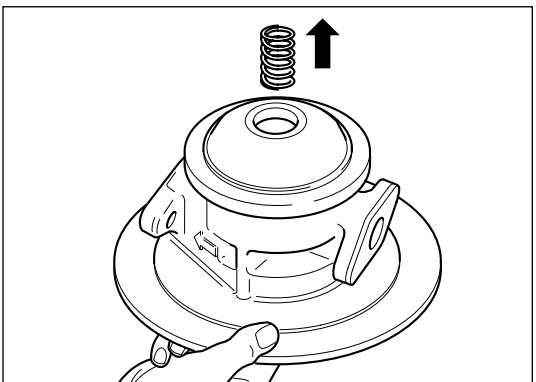
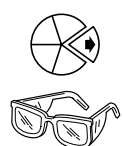





# Component Cleaning

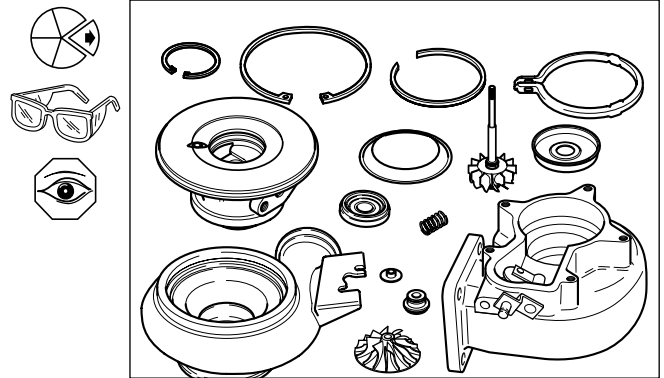

Visually inspect all parts to detect signs of burning and other fault conditions in order to obtain as much information as possible before washing.



Soak the components in a non-corrosive low flash point metal cleaner to loosen deposits.

**Warning**  Always use eye protection when cleaning components.

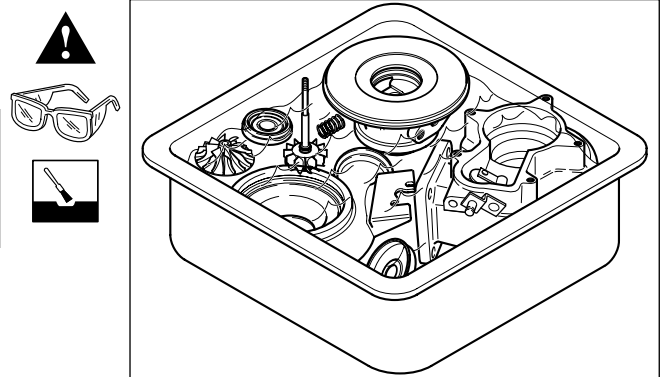

Dry the components using compressed air.  
Protect the sliding surfaces of the cleaned parts against corrosion by applying clean engine oil.



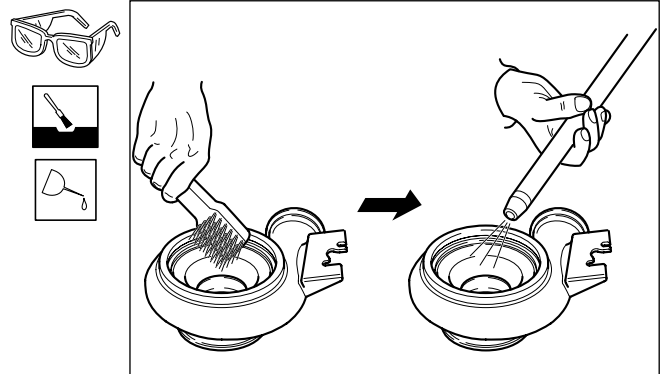

Scale like deposits, if any, must be removed by using a non-metallic bristle brush. After loosening the deposits with the brush, wash and dry components as above.





**Caution**   
 The surface adjacent to the turbine and compressor wheels on the stationary housings must be clean, smooth and free from deposits.

**Caution**   
 Prevent the bead spray hitting the wastegate valve spindle as beads can penetrate the spindle bore leading to spindle seizure.

**Warning**   
 Do not bead blast Aluminium and Cast Iron components together.

**Caution**   
 Prevent the bead spray hitting the wastegate valve spindle as beads can penetrate the spindle bore leading to spindle seizure.

It is permissible to bead blast the turbine housing if chemical and brush cleaning is not effective.

It is important that the oil chamber of the bearing housing is free of carbon before re-building. If heavy deposits persist after repeat washing replace bearing housing (4)

**Caution**   
 Do not bead blast the bearing housing as this may damage critical bearing surfaces.

It is permissible to bead blast steel rotating parts.

**Caution**   
 Blasting specific areas for long periods of time may affect component balance. Protect thread of turbine wheel assembly.

**Caution**   
 Always clean components with compressed air after blasting.

**Caution**   
 Do not bead blast the Aluminium compressor housing as this may damage critical surfaces.

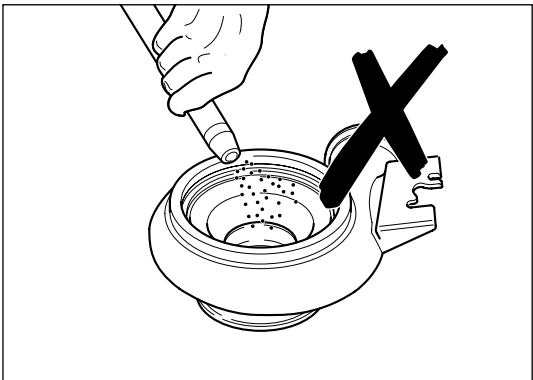
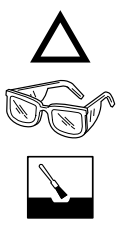
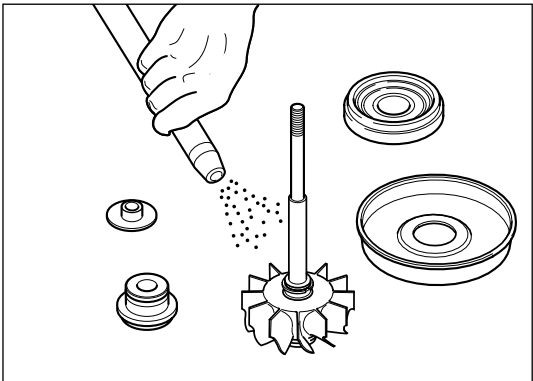
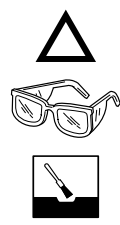
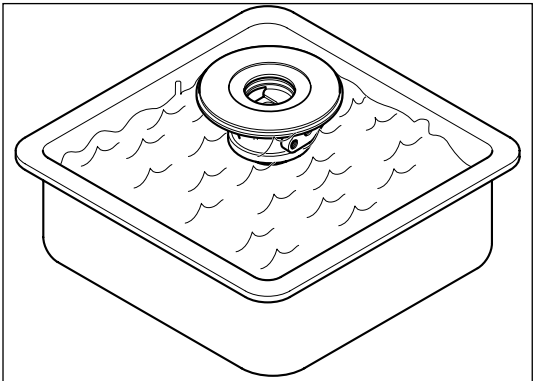
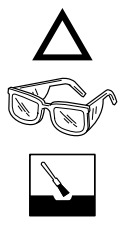
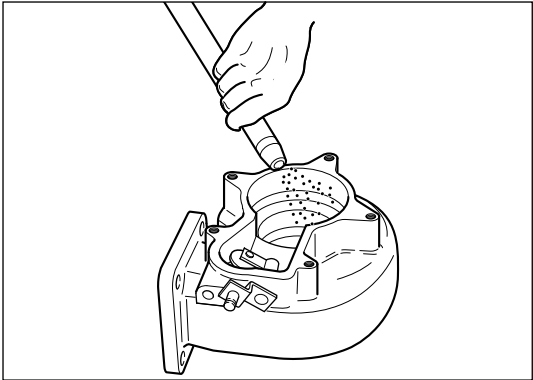

# Inspection and Testing



## Major components

### Assembly turbine wheel

Place assembly, turbine wheel (6) on a vee block. Position a dial gauge on the turned surface of the shaft at the threaded end. Check dial gauge reading. Where shaft bend is greater than the recommended maximum of 0.016 mm (0.0006 in) replace the assembly.

**Caution** Do not attempt to straighten the turbine shaft.

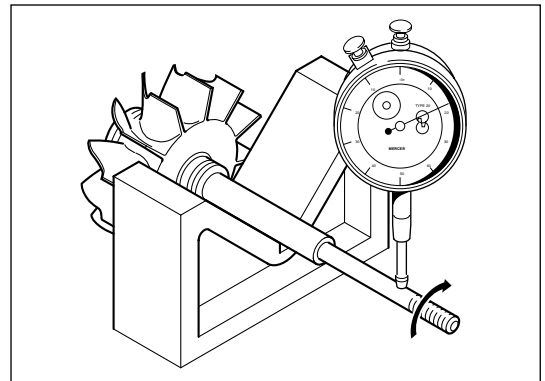

Inspect split ring seal, turbine (13) \* groove walls for wear. If groove width exceeds the recommended maximum of 1.689 mm (0.0665 in) replace assembly.

If the wear step on the ring face exceeds 0.100 mm (0.004 in) replace the split ring seal, turbine.

If the free gap of the ring is less than 2.0 mm (0.08 in) replace the split ring seal, turbine.

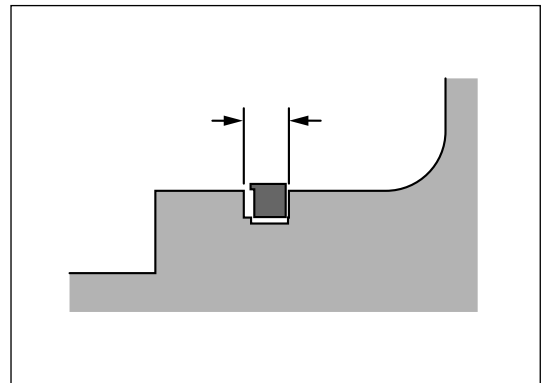

Inspect the bearing journals for excessive scratches and wear. Where scratching is excessive or where either journal diameter is less than the recommended minimum of 10.97 mm (0.43 in) replace the assembly.

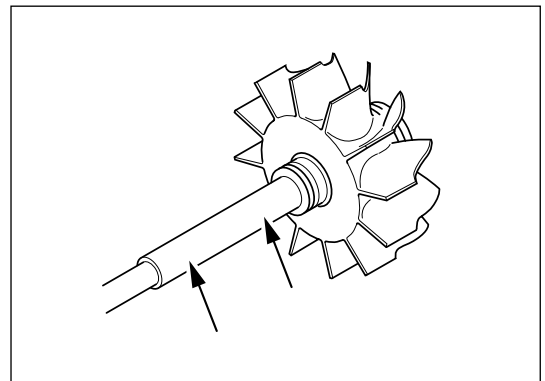

Inspect for cracked, bent or damaged blades.

**Caution** Never attempt to straighten blades.

Replace with new if any damage found.

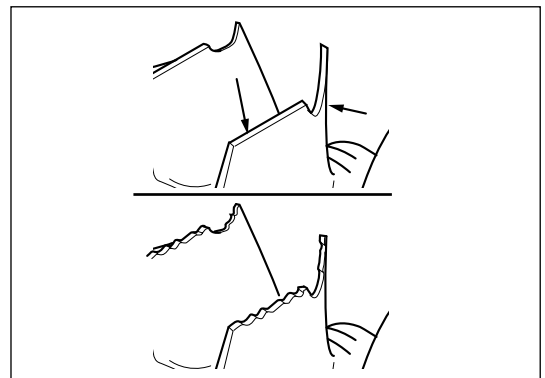



### Compressor wheel

Inspect compressor wheel (7), for cracked, bent or damaged blades.

**Caution** Do not attempt to straighten blades.

Replace with new if any damage found.

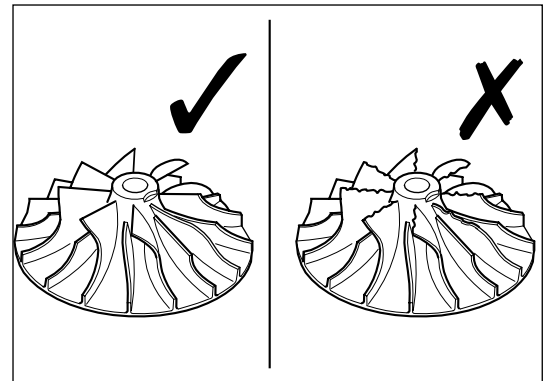

### Compressor housing

Inspect internal profile of compressor housing (8), for scoring damage due to possible contact with compressor wheel. Check compressor cover retaining ring (91) groove is free from deposits.

Return to **Component Cleaning** if deposits remain.

Replace with new if profile damage is visible.

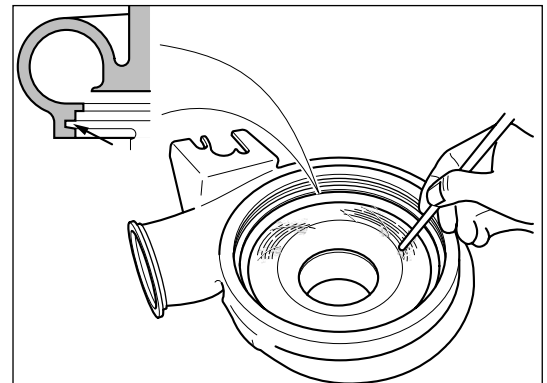

Ensure position of compressor housing retaining ring groove has not been compromised by wear.

**Caution** Good groove and abutment face condition are critical to the integrity of compressor housing to bearing housing joint.

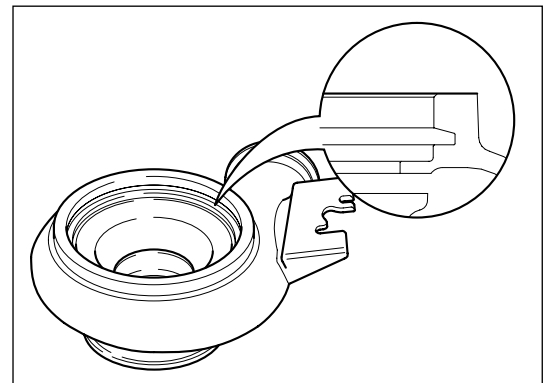

### Cover plate option

Check cover plate (88) flange sealing faces for cracking and distortion. Check exhaust system connecting profile for fretting damage.

If sealing is compromised replace cover plate, if available.

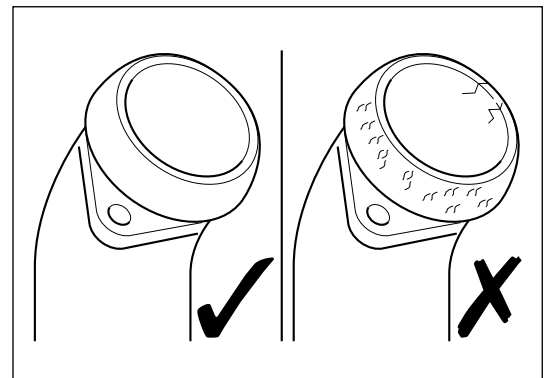



M8 (13 mm)

**Caution**  Take care not to shear the 5 coverplate bolts.

Remove cover plate option.

Seized bolts may be freed by spraying with penetrating oil and soaking for 20 minutes or a period of time recommended by the oil manufacturer.

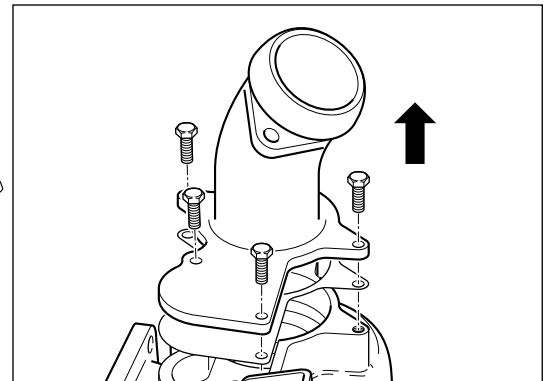
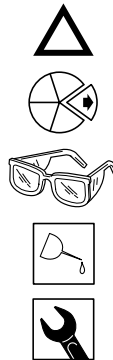

### Turbine Housing

Inspect the turbine housing (5) profile for damage caused by possible contact with the rotor. Inspect the outer and internal walls for cracks or flaking caused by overheating.

Check turbine housing inlet flange flatness is within 0.1 mm (0.004 in). Check fastener hole diameter is not more than 1.5 mm larger than the max. thread diameter of the fastener.

Replace with new if any of the above features are non compliant.

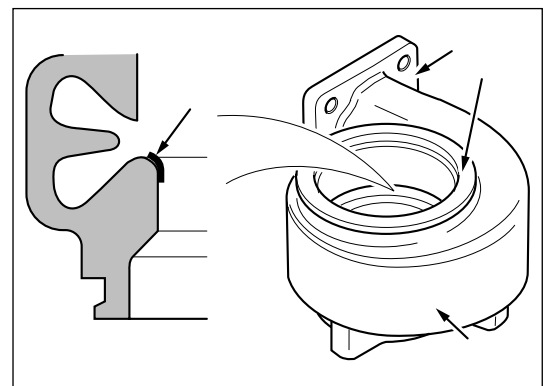

After washing, the wastegate valve mechanism may remain seized or stiff to operate. If so, soak the mechanism in penetrating oil for approximately 20 minutes or a period of time recommended by the oil manufacturer.

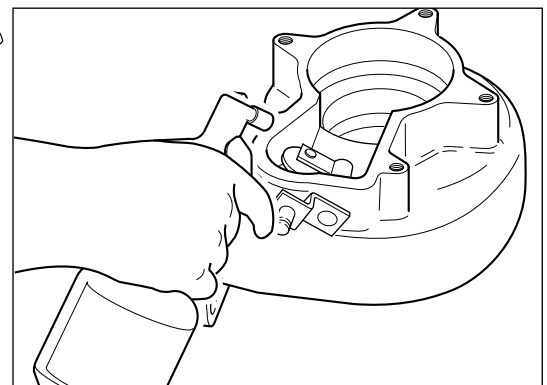
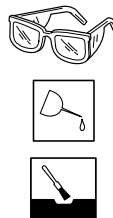

Some turbine housing options do not have open access to the wastegate valve but, with care, soaking with penetrating oil may still be possible.

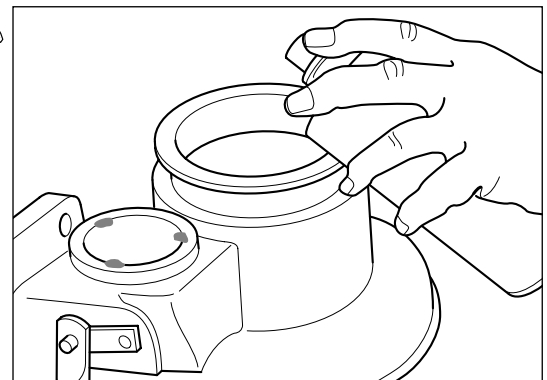
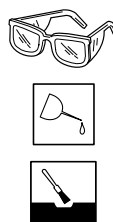



**Caution**   
 Extra care must be taken when attempting to free the valve mechanism. Any damage will result in the replacement of the turbine housing.

Clamp a pair of quality mole (vice) grips to the lever and gently apply pressure to rotate the lever arm in an arc.  
 If this process does not free the valve mechanism, a new turbine housing must be fitted.

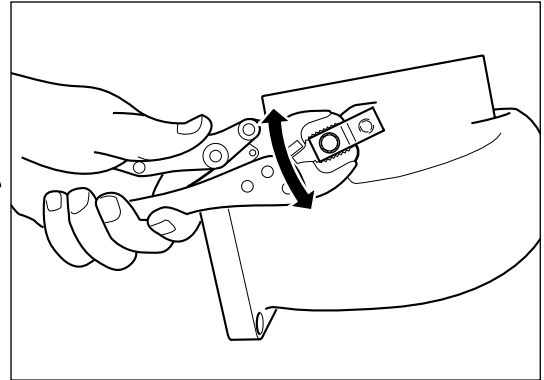
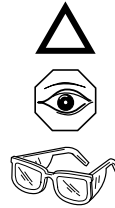

Check the wastegate lever arm for evidence of rubbing or cracking. Replace with a new turbine housing if damage is visible.

Check the lever arm pivot for evidence of fretting damage, wear or cracking.

Check the lever arm for cracking and or misalignment due to mechanical damage.

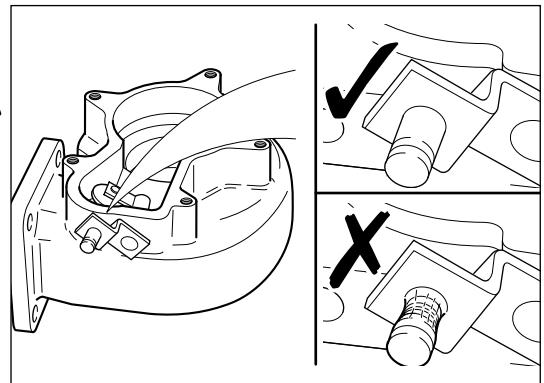

**Caution**   
 If the wastegate valve mechanism shows any fault, it must be replaced. Using damaged turbine housings will lead to inferior performance of the turbocharger, and risk of irreparable damage to both turbocharger and engine.

Radial cracks can occur around the valve seat when the turbocharger has been abused or overheated.

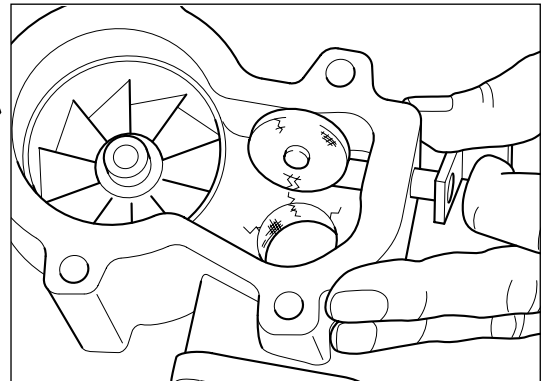

**Wastegate**

Inspect the wastegate rod end bore which locates on the lever arm pin for elongation. Ovalisation must not exceed 0.50 mm (0.020 in).

**Caution**   
 If the wastegate shows any fault, it must be replaced.

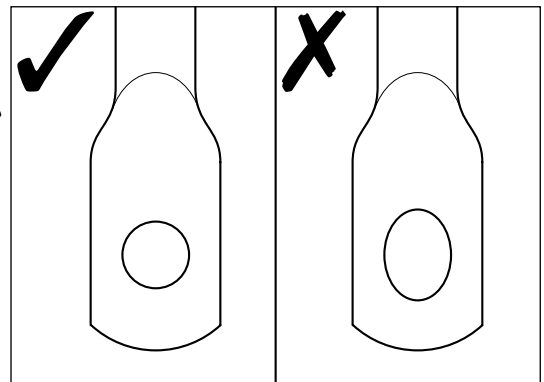



### Bearing Housing

Inspect journal bearing bores for wear and score marks. Replace bearing housing (4) if a bore diameter exceeds a maximum of 15.88 mm (0.625 in) or when bore scratching is severe.

Ensure groove locations for retaining rings, bearing (64) do not exceed width dimension of 0.82 mm (0.032 in) and are free from deposits.

**Note**  
Bearing housings of with spring separated bearings do not have inboard retaining ring grooves.

Check that the oil cavity is free from carbon and any entrained debris that may be the result of a failure.

Check oil seal plate, retaining ring groove does not exceed a maximum width dimension of 2 mm (0.079 in).

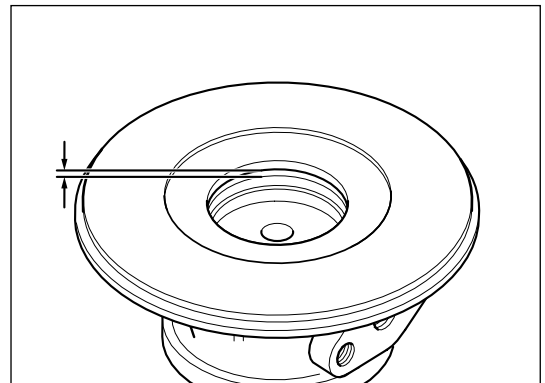
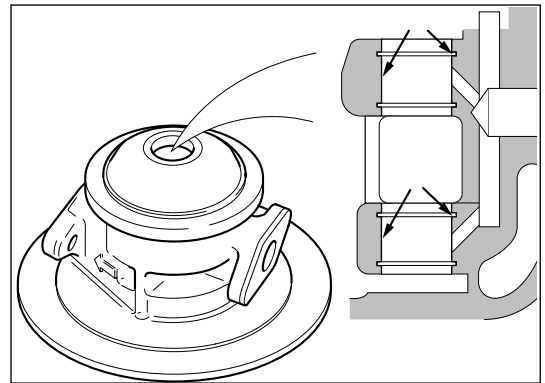

### Small Components

#### Oil Slinger

Inspect and replace oil slinger (31) if the split ring seal, compressor (16) \* groove walls are scored or damaged or if groove width exceeds a maximum of 1.67 mm (0.066 in).

Check for signs of rubbing and scoring on the thrust surface and replace where damage is severe.

If the ring faces show any signs of wear replace the split ring seal, compressor.

If the free gap of the ring is less than 2.0 mm (0.08 in) replace the split ring seal, compressor.

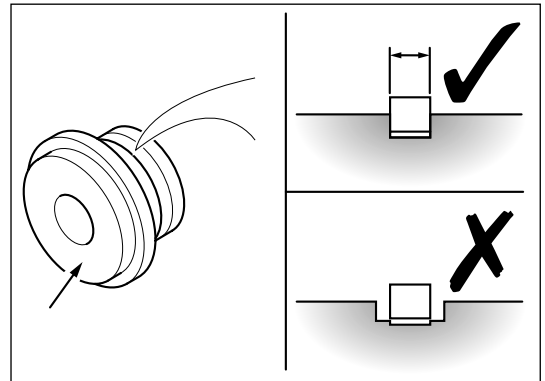

#### Oil seal plate

There are plastic and steel versions of the oil seal plate (43). Always replace the plastic seal plate with the steel equivalent.

Inspect the seal bore of the steel component and replace if scored or damaged.

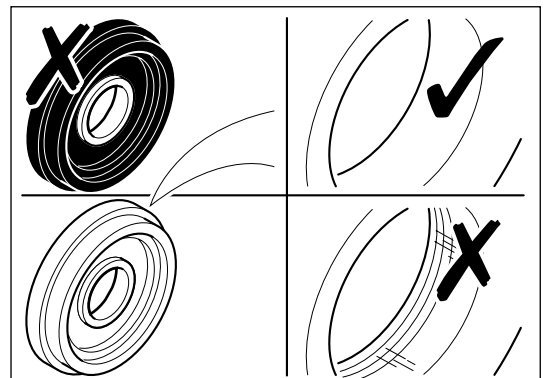



### Heat Shield

Check and replace if the heat shield (38) is distorted or if signs of rubbing or cracking are visible.

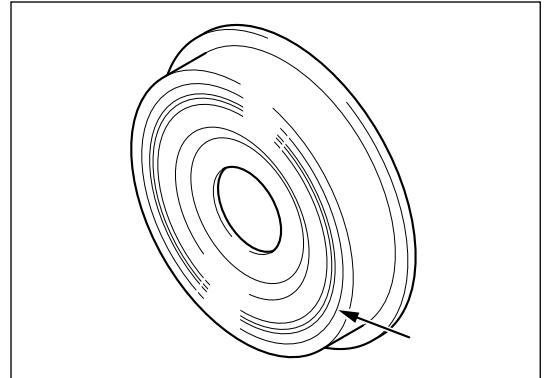

### Thrust Collar

Check and replace if thrust collar (36) is scored on thrust face or if any cracks are visible.

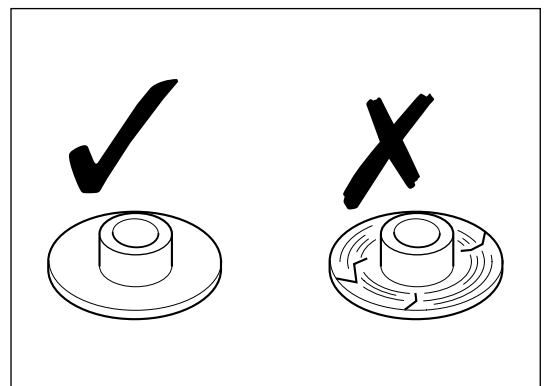



# Reassembly



## Rotor Balance

**Caution** This turbocharger may have been manufactured using the 'core balance' process. Rotor balance **MUST** always be checked on re-build.

A core balance turbocharger will not have any co-relation marks on the thrust collar or oil slinger. It should always have co-relation marks on the end of the turbine shaft and impeller nose if it has been disassembled according to the process defined in **Disassembly**.

Components that should be included in rotor balance are:

- Turbine wheel and shaft
- Thrust collar
- Oil slinger
- Compressor wheel
- Nut

Balance is achieved by relative rotation of components as indicated by the balance machine output.

The balance process requires a purpose built rig and compliance with the rig procedure.

Rotor balance limits appear in the **Service Data Sheet**.

On achieving balance, parts should be permanently marked for subsequent re-alignment during reassembly.

**Caution** Only use genuine Holset compressor wheels and assembly turbine wheels which are individually check balanced for long life and quiet operation.

**Caution** Always make sure the balance marks on the rotor assembly are in alignment when rebuilding the turbocharger.

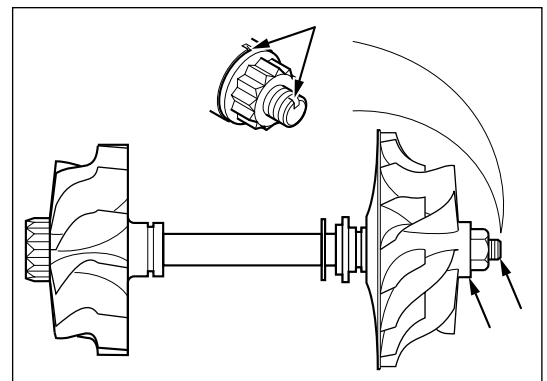
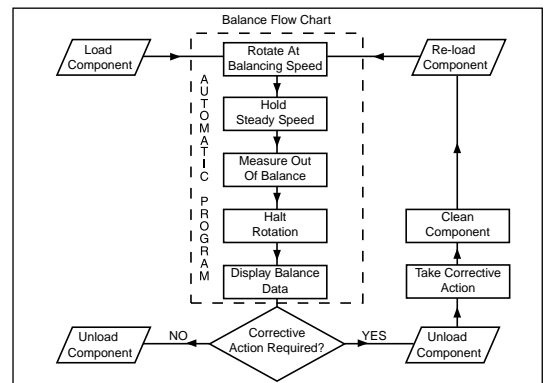
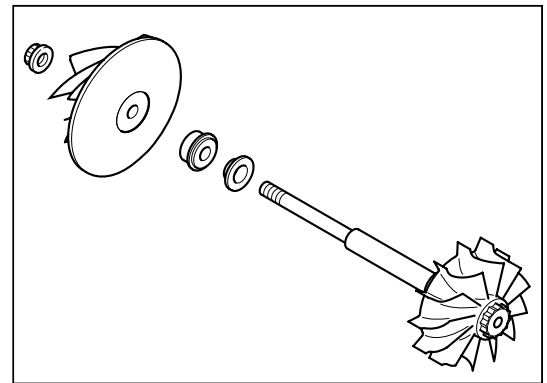
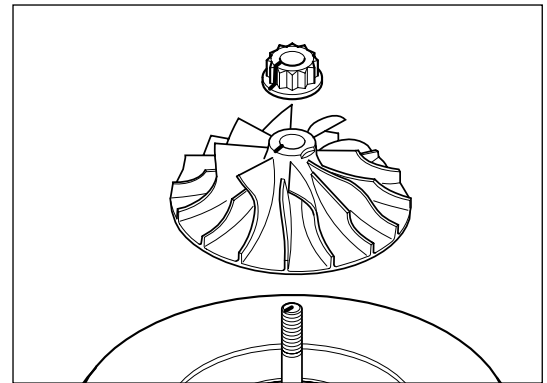



## Turbocharger Reassembly Circlip Retained Journal Bearings

### Warning

Always wear safety glasses when fitting retaining rings.

### Caution

Make sure the circlips are always fitted with the bevelled edge facing the journal bearing. Premature failure will result from incorrect fitting.

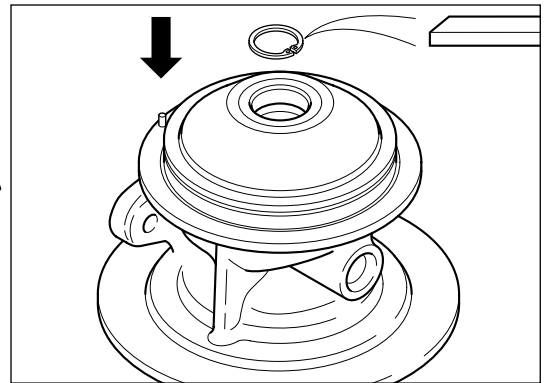

Place bearing housing compressor mating face on a clean surface.

Fit turbine end retaining ring, bearing (64) \* using circlip pliers Part No. 56664.

Lubricate the journal bearing (11)\* with clean engine oil and install

Fit the outer retaining ring (64)\*.

Turn the bearing housing over and fit retaining rings (64)\* and bearing (11\*) at compressor end.

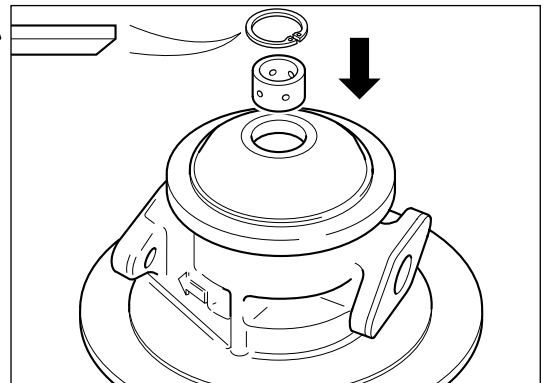
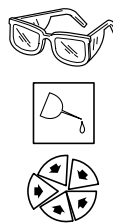

## Spring Separated Journal Bearings

### Note

Some HY35W models contain spring separated journal bearings. Ensure the spacer spring (127) is refitted during journal bearing reassembly where the bearing housing does not feature inner retaining ring grooves.

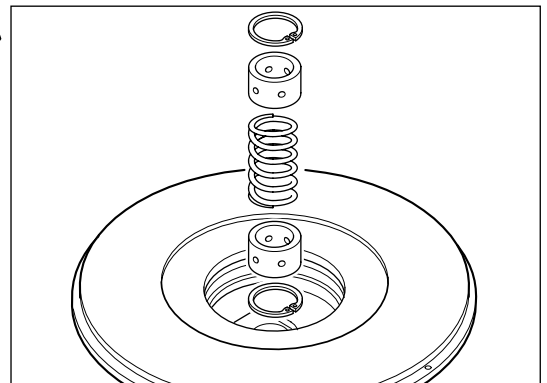
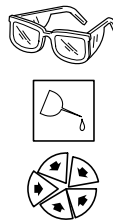

Install heat shield (38).

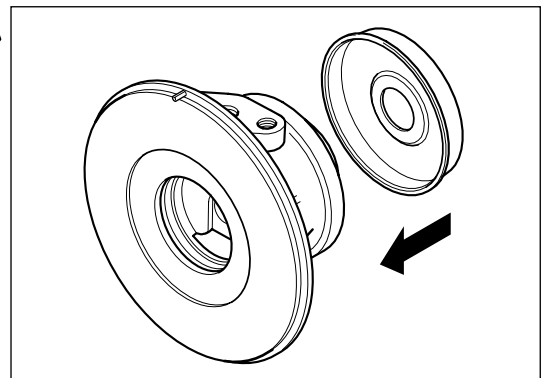



Install new piston ring seal, turbine (13) \* to assembly turbine wheel.

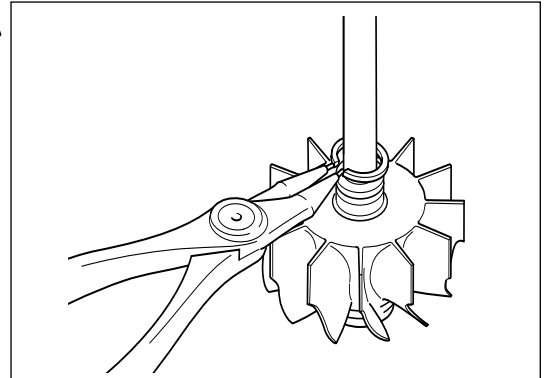

Lubricate the shaft with clean engine oil and insert into the journal bearings. Positively locate the seal ring (13) \* into position and ensure the assembly turbine wheel rotates freely.

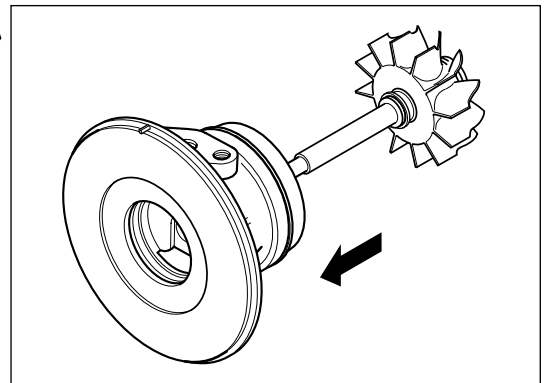
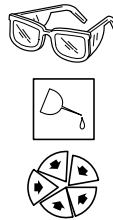

Place assembly on clean flat surface supporting the assembly turbine wheel (6) in a suitable fixture.

Ensure all thrust contact faces are clean.

Insert thrust collar.

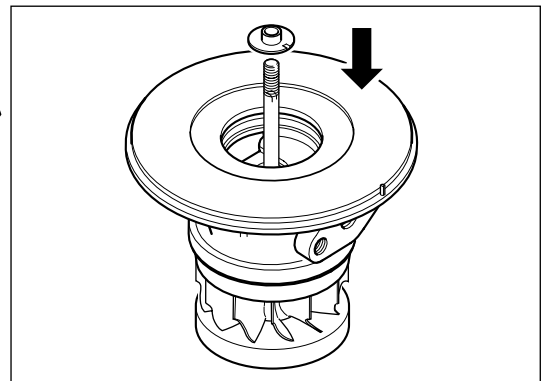

**Caution** Align the balance mark on the thrust collar with that on the shaft, if applicable.

Apply engine oil to installed thrust collar (36) and insert thrust bearing (12) \*.

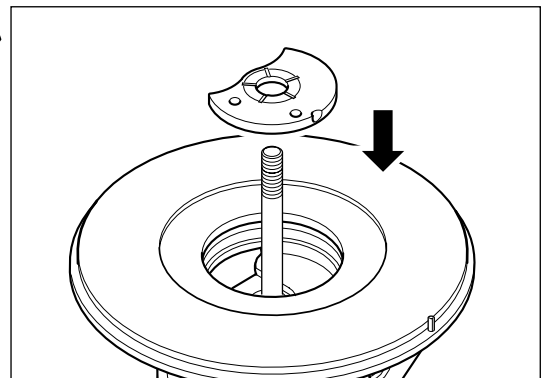



Insert the O-ring seal, bearing housing (32) \*.

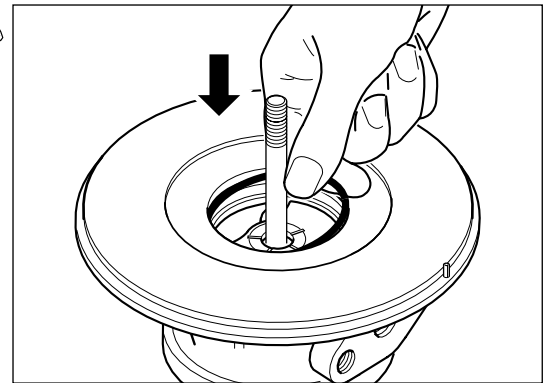

Fit new piston ring seal (16) \* to oil slinger (31).

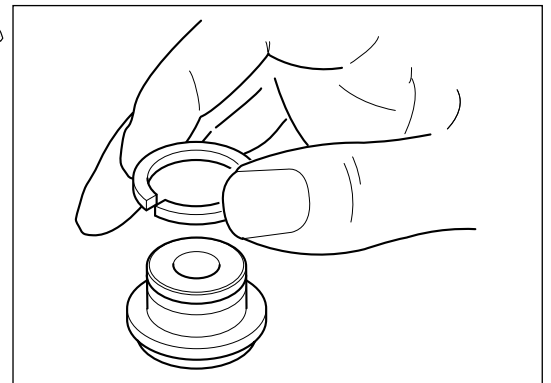

Install oil slinger (31) into steel oil seal plate (43).

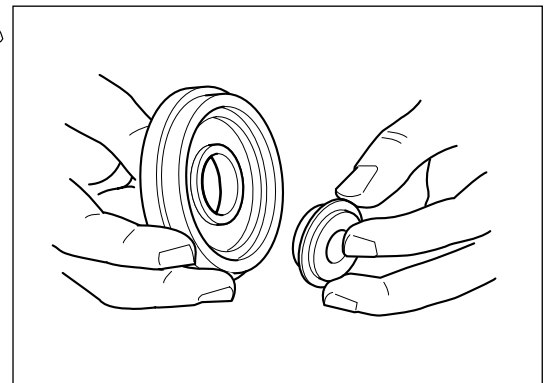

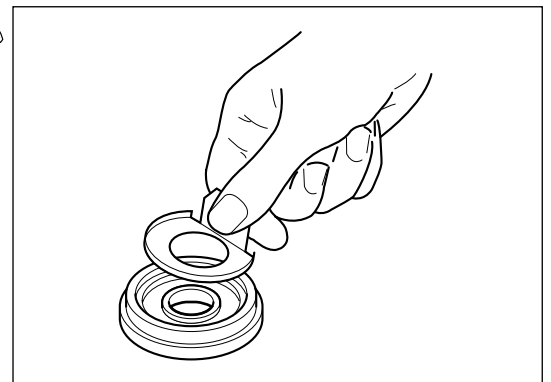

Install the oil baffle (33) \* into the oil seal plate (43).



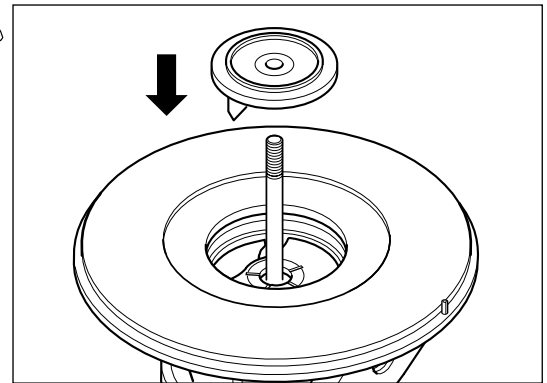

Align the tongue of the oil baffle with the aperture in the bearing housing and install the seal plate assembly.



**Caution**  Align the balance marks on the oil singer (31) with that on the shaft end, if applicable.

The oil seal plate assembly will require finger pressure to overcome O-ring seal (32) \* pre-compression and achieve its axial location.

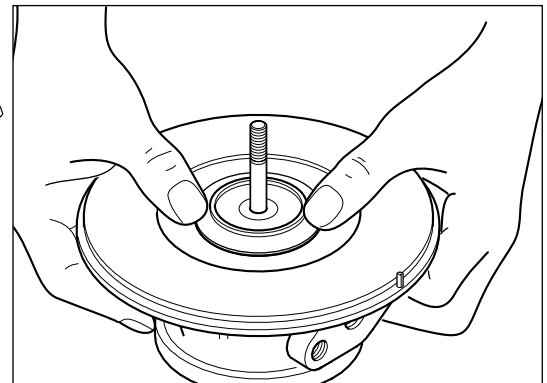

Use circlip pliers Part No. 56662 to install the insert, retaining ring (66).

**Caution**  The retaining ring must be fitted with the chamfered face upwards away from the oil seal plate.

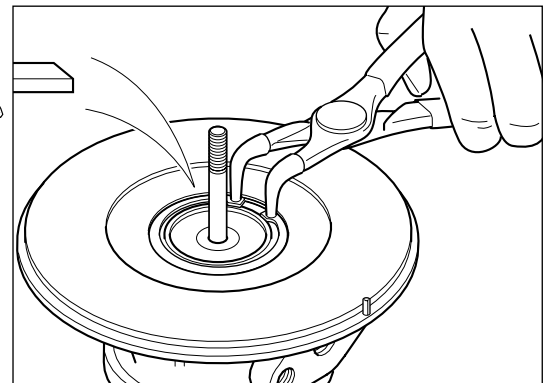

Use soft hammer and drift to ensure retaining ring (66) is properly located.

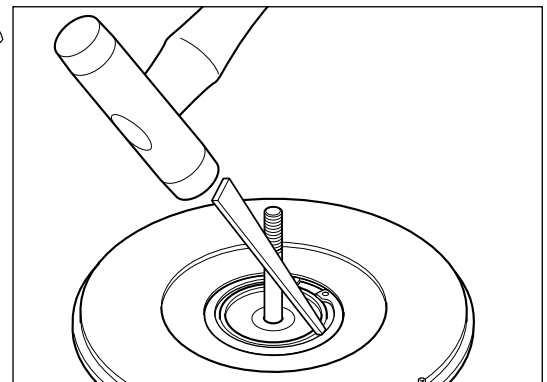



Ensure that back face of compressor wheel (7) is clean and free from damage. Install on to the shaft.

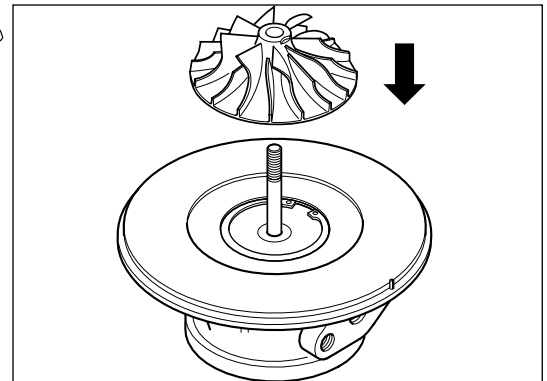

Align the balance marks scribed on shaft and compressor wheel.

Brush the thread and nut face with an anti-seize compound to avoid loss of alignment during torque tightening.

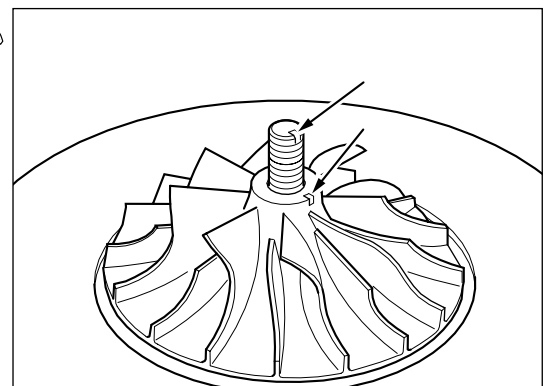
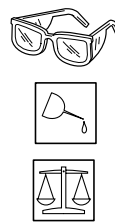

M7 LH (10 mm)

Install the compressor wheel lock nut (61) and tighten to the torque value defined in the **Service Data Sheet**.

**Caution** Ensure that the balance marks remain aligned on compressor wheel and shaft throughout the torque tightening sequence.

**Note**  
Left handed thread.

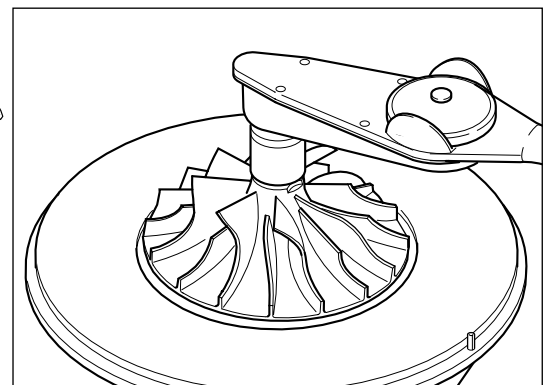
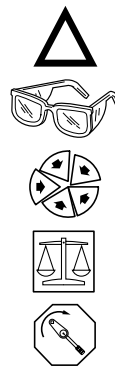

Place compressor housing (8) on clean surface. Carefully slide the CHRA (2) assembly into the compressor housing. Use alignment marks to locate assembly on to the dowel pin fixed into the bearing housing.

**Caution** The compressor wheel blades can be easily damaged when the CHRA is installed.

**Caution** Be careful not to bend the location pin during assembly.

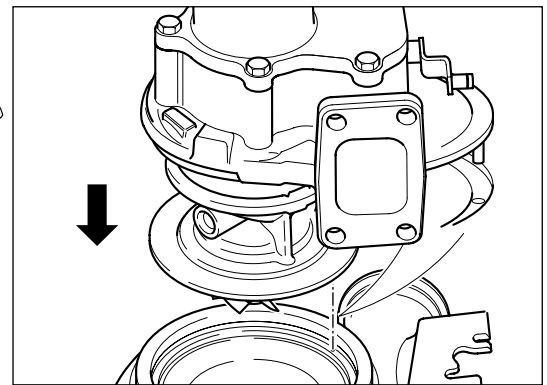



Locate compressor cover retaining ring (91) over CHRA. Using circlip pliers, part no. 3575186, fit the retaining ring.

**Caution**  The retaining ring must be fitted with the chamfered face upwards away from the compressor housing.

Using a soft hammer and drift, ensure retaining ring is properly located.

**Caution**  Ensure that drift does not damage bearing housing during this operation.

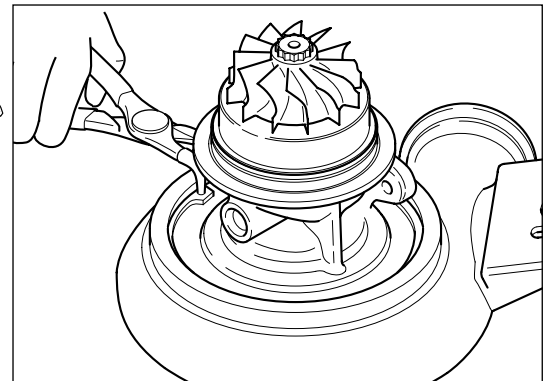

Position V-band clamp (28) over the bearing housing and align indelible ink marks applied during disassembly.

Apply anti seize compound to bearing housing locating bore of the turbine housing.

Carefully slide the turbine housing onto the CHRA. Use ink alignment mark to locate assembly on to the dowel pin fixed into the bearing housing.

**Caution**  The turbine wheel blades can be easily damaged when the turbine housing is installed.

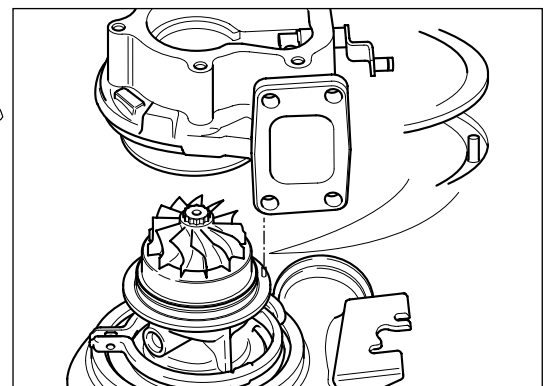

M6 (10 mm)  
Place V-band clamp (28) in position and torque tighten new V-band locknut (62) \* to value specified in [Service Data Sheet](#).

Ensure rotor assembly freely rotates.

**Caution**  Be careful not to bend the location pin during assembly.

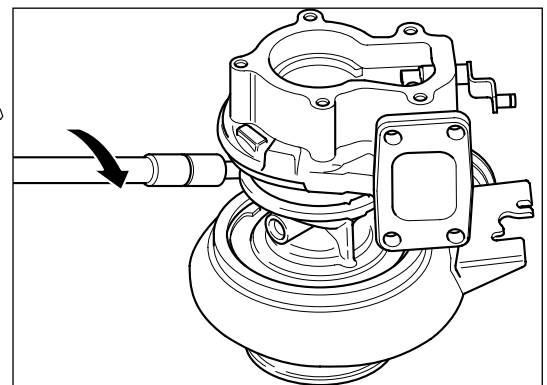
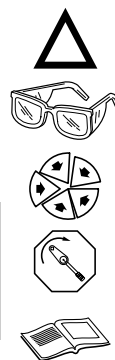

Check thrust clearance using a dial gauge. Ensure clearance is within MIN/MAX values shown on [Service Data Sheet](#).

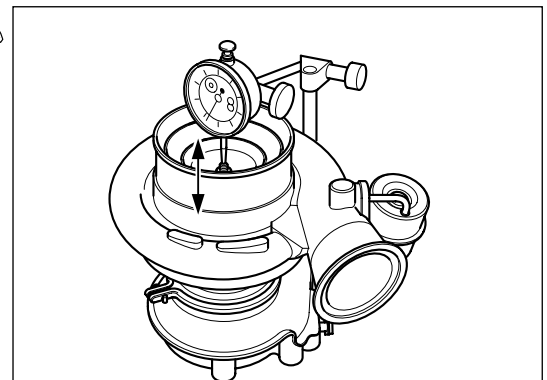
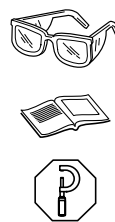



Check compressor end radial movement using a dial gauge. Ensure clearance lies within MIN/MAX TIR (Total Indicator Reading) values shown on [Service Data Sheet](#).

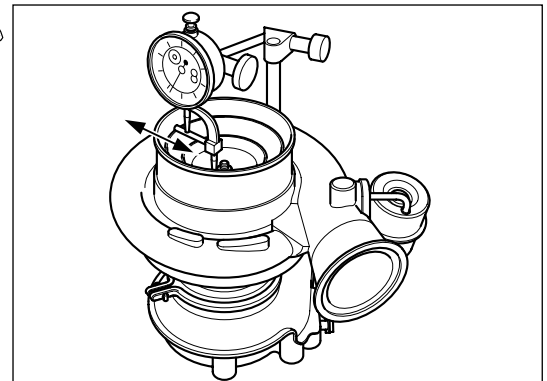
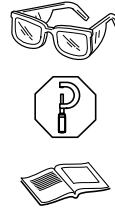

### Pre-set Wastegate Actuator Reassembly

**Caution** 

Contact your local approved dealer for the correct replacement actuator kit (74). It is important to quote the correct turbocharger assembly number, serial number and type to ensure the supply of the correct pre-set actuator.

**Note**

When refitting existing actuator the end link (76) will be locked in the correct setting.

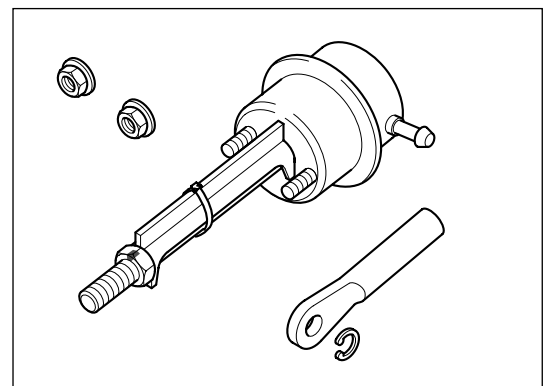

Thread new end link (76) several turns on to the shaft of the new pre-set actuator assembly (73).

Hold the actuator assembly with the spine of the spacer piece upright. Rotate the valve mechanism lever arm to close the wastegate valve (pushed towards the compressor end). Fit end link (76) over the lever arm pin.

Attempt to slide the pre-set actuator (73) over its retaining bracket. If the actuator fouls on the bracket or there is significant clearance between bracket and actuator base, actuator rod length requires adjustment.

**Note**

Do not fit the wastegate studs to the bracket at this stage.

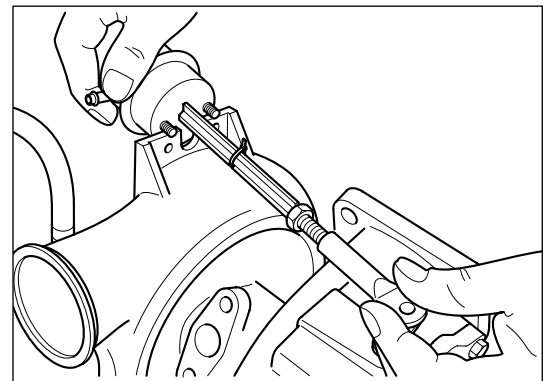

To adjust the length of the actuator assembly, remove from the turbocharger. Rotate the end link (76) to shorten or lengthen the rod as appropriate. Re-fit, until the underside of the pre-set actuator (73) will just fit over the bracket mounting face with less than 0.5 mm (0.020 in) gap.

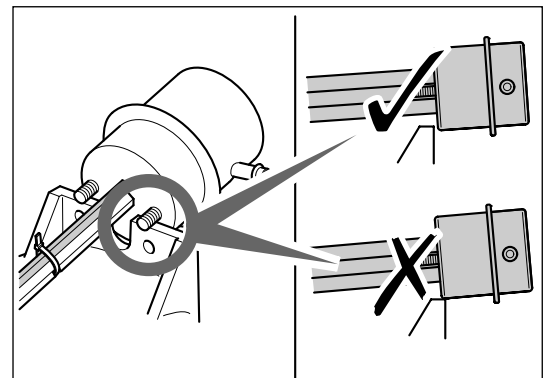





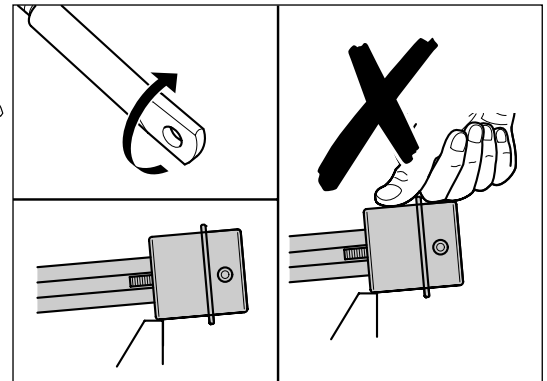

**Caution**  Do not apply force to push the actuator on to the mounting face of the bracket.

The rod length setting is correct if, by rotating end link (76) clockwise by a half turn, the actuator body fouls on the bracket.



1/4 - 28 UNF 2B (7/16 in)

Remove the pre-set actuator assembly from the lever arm ensuring that the end-link (76) does not rotate. Fit actuator mounting studs into their locating holes (or slots) in the bracket. Fit both actuator mounting nuts (83) and torque tighten to the value shown in the [Service Data Sheet](#)

**Caution**  Ensure wastegate with integrated feed is properly fitted to compressor housing with o-ring seal (27).

**Caution**  Do not rotate actuator rod relative to actuator as this can damage actuator internal components.

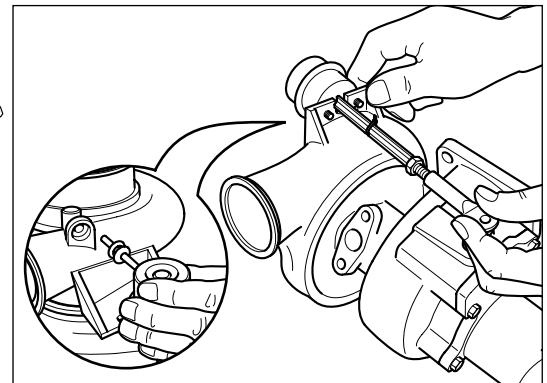

Re-fit end link to the lever arm pivot pin. Fit new end link, retaining clip (77) using service tool Part No. 4027202 to retain rod end on pin.

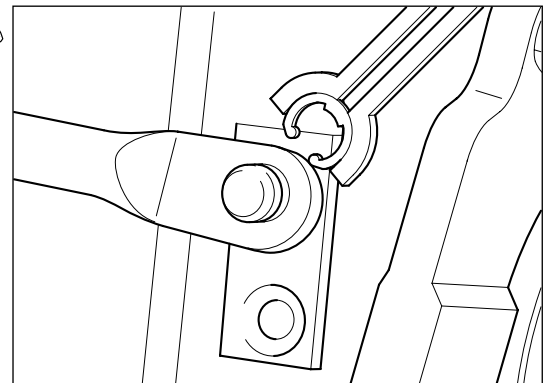

5/16 - 24 UNF 2B (1/2 in)

Loosen spacer piece by turning jam-nut (128) anti-clockwise (counter-clockwise). Remove and discard tie wrap and spacer piece.

Continue turning jam-nut (128) in the same direction, and torque tighten against end link (76) to value shown in [Service Data Sheet](#).

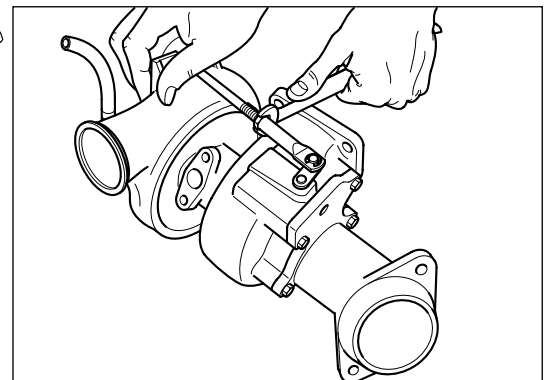
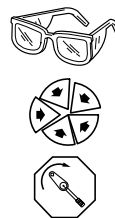



New pre-set actuator kits (74) may be supplied with a tamper resistant break off nut (143) instead of a jam nut (128) to secure the end link in its correct pre-set position. To install a tamper resistant actuator

1. Slacken the shear nut from the spacer spine
2. Continue to turn the nut until it contacts the pre-set end link
3. Continue tightening until the hex flats break off leaving only the cone section in tight contact with the end link.

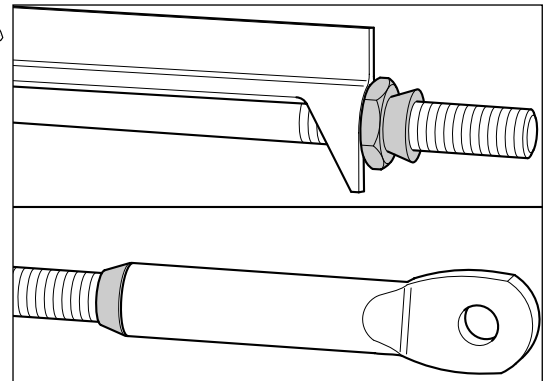
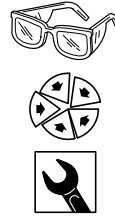

### Hose Fed Actuator Option

On hose fed actuator options, refit the air supply hose with new hose clips (75). Clips should be crimped closed using piners. Crimp gap will vary due to spring back and hose type but will not be less than 0.6 mm (0.025 in).

Suitable alternative hose clamps can be used.

#### Caution

Before mounting turbocharger on engine, check for full and free wastegate movement.

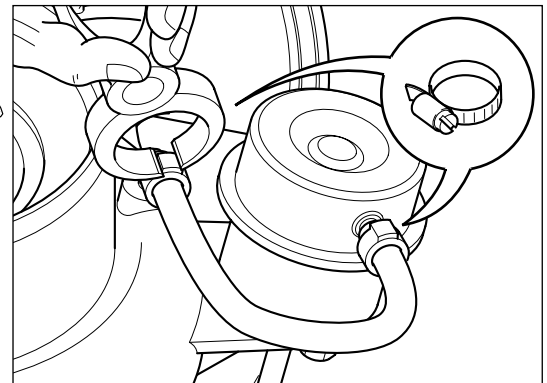

M8 (13 mm)

Replace cover plate (option) (80) and tighten cover plate bolts (67) to torque value specified in the [Service Data Sheet](#).

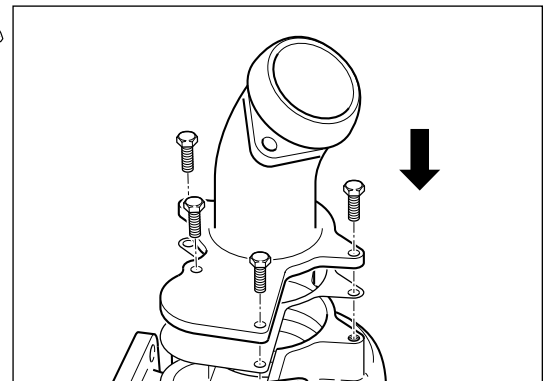
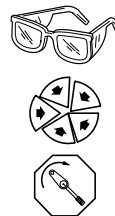



# Holset HY35W

## Service Repair Manual

Cummins Turbo Technologies Ltd.  
Aftermarket Division  
Croset Avenue  
Huddersfield  
West Yorkshire  
HD1 6SE  
[www.holsetaftermarket.com](http://www.holsetaftermarket.com)